



KRISHNA INSTITUTE OF MEDICAL SCIENCES “DEEMED TO BE UNIVERSITY”, KARAD

Accredited by NAAC with 'A' Grade (CGPA: 3.20 on 4 Point Scale)

An ISO 9001:2015 Certified University

NIRF Rankings 2020 - University Ranking 90, Medical College Ranking 37

Declared U/s 3 of UGC ACT, 1956 vide Notification no.F.9-15/2001-U.3 of the Ministry of Human Resource Development, Govt. of India
Karad, Dist. : Satara (Maharashtra State) Pin : 415539 Tel : 02164-241555-8 Fax: 02164-243272/242170
Website : www.kimskarad.in E-mail: registrar@kimskarad.in

ADDITIONAL INFORMATION FOR

BEST PRACTICE 2

INDEX

Sr. No.	Name of Document	Page No.
1.	KIMSDU has been ranked 5 th as “SWACHH CAMPUS”	1-2
2.	KIMSDU as “GREEN INSTITUTIONAL MENTOR”	3
3.	KIMSDU is now recognized “SOCIAL ENTREPRENEURSHIP, SWACHTA & RURAL ENGAGEMENT CELL (SES REC) INSTITUTION”	4
4.	KIMSDU has initiated 5000 tree plantation program under TRIPARTY AGREEMENT of afforestation with Government of Maharashtra, forest department, Satara.	5-17
5.	KIMSDU had an opportunity to be member of Indian green building council (IGBC)	18-19
6.	Krishna Hospital and Medical Research Centre was ranked 1st as a Clean Hospital in “Swachh Sarvekshan 2020” among the Hospitals in Malkapur Nagarparishad, Tal. Karad, Dist. Satara.	20-21
7.	KIMSDU (Energy Audit 2016 & 2019)	22-103
8.	KIMSDU (Green Audit 2019)	104-150
9.	KIMSDU (Environmental Audit 2019)	151-220
10.	KIMSDU Certification of ISO 14001:2015 (Environmental Management System)	221

Swachh Campus Ranking 2018 of Higher Educational Institutions



REGISTRAR
Krishna Institute of Medical Sciences
"Deemed To Be University", Karad

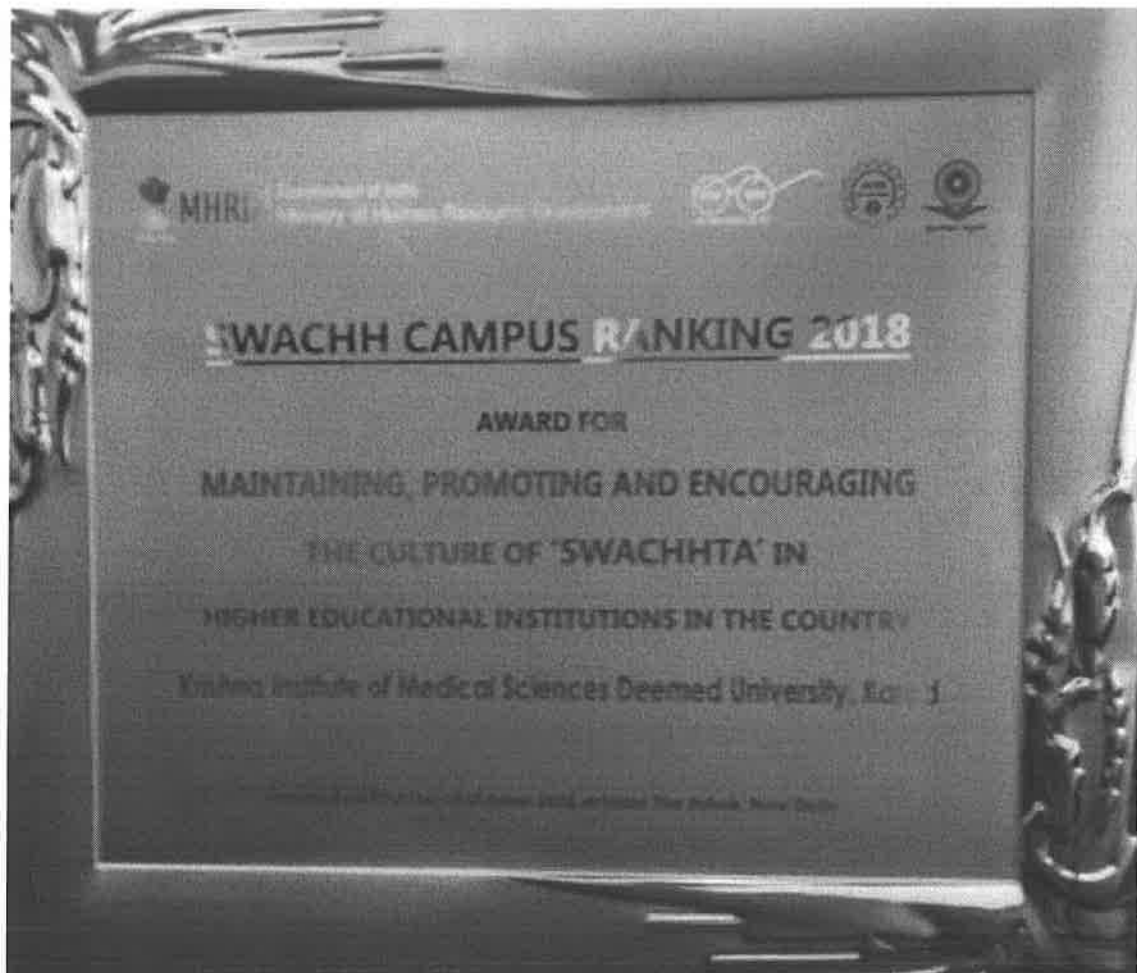

Commendation Award – Green Institutional Mentor Award



महात्मा गांधी राष्ट्रीय ग्रामीण शिक्षा परिषद Mahatma Gandhi National Council of Rural Education

(Formerly National Council of Rural Institutes)
Department of Higher Education, Ministry of Human Resource Development, Government of India



Lr.No.08/MGNCRE/MHRD/NatConfWater/08-03-2020

Dr. M.V. Ghorpade
Registrar
Krishna Institute of Medical Sciences
Karad, Maharashtra

Sub:-MGNCRE-MHRD GOI – Presentation "Green Institutional Mentor Award" National Conference on Industry-Academia Interaction - Water Management – 22nd March 2020– Exemplary Performance Awards - Invitation - Reg.

Dear Ghorpade ji,

Namaskar! Congratulations from Mahatma Gandhi National Council of Rural Education (MGNCRE)!

The MGNCRE in Ministry of Human Resource Development in Government of India recognizes you as one of the Exemplary Performers in campus water and sanitation management. Your contribution to the field of water conservation is well appreciated and we congratulate you earnestly for promoting professionalism and capacity building in water and sanitation management in your campus. We are pleased to recognise you as "Green Institutional Mentor" for your Exemplary Performance in Water and Sanitation Management. We cordially invite you to receive a Commendation Award "Green Institutional Mentor" on 22nd March 2020 at Hyderabad.

We cordially invite you to join us in this endeavor for promoting campus water and sanitation management. In this context, we are organizing this Awards Function as part of the National Conference on Industry-Academia Interaction for Water Management on 22nd March 2020 at Hyderabad where key stakeholders including HRD Ministry Officials and Industry will participate and share their experience in sanitation and water conservation and management. You can put forth a presentation of about 5 minutes (5 PPT slides or a 2 minute video document) on your work in your campus/area of expertise. Please find attached our manual – Jal Shakti Campus and Jal Shakti Gram – developed at the instance of the Ministry, as one of the references for you to prepare your presentations. The schedule of the program is also attached.

We request you to kindly confirm your acceptance to the invitation to receive the Green Institutional Mentor Award on inmensap@gmail.com to block your accommodation. We look forward to your dynamic presence to receive this Green Institutional Mentor Award in the National Conference on water on 22nd March 2020 at Administrative Staff College of India College Park, Banjara Hills, Hyderabad.

Thanking you.

Yours sincerely,

Dr. W G Prasanna Kumar
Chairman MGNCRE

5-10-174, Shakkar Bhavan, Ground Floor, Fateh Maidan Road, Hyderabad - 500 004.
Tel: 040-23212120, 23422105. Fax: 040-23212114, Email: wgp.kumar@gov.in, www.mgncre.in

**KIMSDU is Recognized Social Entrepreneurship, Swachhta & Rural
Engagement Cell (SES REC) Institution by
Mahatma Gandhi National Council of Rural Education, Department of
Higher Education, Ministry of Education, Government of India**



Certificate



This is to certify that KRISHNA INSTITUTE OF MEDICAL SCIENCES "DEEMED TO BE UNIVERSITY", KARAD is now a Recognized Social Entrepreneurship, Swachhta & Rural Engagement Cell (SES REC) Institution. The Institution has successfully framed the SES REC Action Plan and constituted ten working groups for improving facilities in the Campus and the Community/Adopted Villages in the areas of Sanitation & Hygiene, Waste Management, Water Management, Energy Conservation and Greenery post COVID-19, along with the observation of three environment, entrepreneurship and community engagement related days to inculcate in faculty, students and community, the practices of Mentoring, Social Responsibility, Swachhta and Care for Environment and Resources.

Date of Issue: 30-08-2020

Dr. W G Prasanna Kumar
Chairman

Mahatma Gandhi National Council of Rural Education
Department of Higher Education, Ministry of Education
Government of India

Certificate No.: MoE/SESREC/MH/Karad/02

TRIPARTY AGREEMENT OF AFFORESTATION

Between

Government of Maharashtra, Forest Department, Satara Forest Division, Satara

And

**Krishna Institute of Medical Sciences "Deemed To Be University", Karad
Tal. Karad, Dist. Satara, State: Maharashtra**

And

**Sankalp Samajik Vaa Shaikshanik Sanstha
A-Bhivadi, P-Triputi, Tal-Koregaon, Dist.-Satara, Sate: Maharashtra**



महाराष्ट्र MAHARASHTRA

2019

VH 713395

जोडण्याचे क्रमांक / Amount in I & II 200

पट्टे रक्कम

REGISTRAR

Krishna Institute of Medical Sciences
"Deemed To Be University", Karad

क्र. सं. म. सा. वि. 117

524 क्रमांक 29212090

[Signature]

[Signature]

भारत सरकार - श्री. अशोक शिंदे
पुणे-411 002/1955

महाराष्ट्र शासन - श्री. अशोक शिंदे
पुणे-411 002/1955

TRIPARTY AGREEMENT OF AFFORESTATION

This Agreement is made at Satara on this 27th day of December 2019 by and between Government of Maharashtra, Forest Department, Satara Forest Division hereinafter referred to as "the Government" (which expression shall unless the context does not so admit include his successors and permitted assigns) of the One Part and



Deputy Conservator of Forest
Satara Forest Division, Satara.



Krishna Institute of Medical Sciences "Deemed To Be University", Karad incorporated under section 3 of UGC ACT, 1956 and having its Registered office at Tal. Karad, Dist. Satara hereinafter referred to as the "Licensee" (which expression shall unless the context does not so admit include its successors and permitted assigns) of the **second part** and

Sankalp Samajik Vaa Shaikshanik Sanstha, a Public Charitable Trust duly registered under the Bombay Public Trusts Act, 1950 having its head office at **A-Bhivadi, P-Triptuti, Tal-Koregaon, Dist.-Satara** hereinafter referred to as the "NGO" (which expression shall unless the context does not so admit include its successors and permitted assigns) of the **Third Part**,

Whereas, with a view to accelerating the Afforestation work on the degraded forest areas having density of 0.04 within the state of Maharashtra, the Government has decided to implement through its Forest Department with the assistance of the forest officers at Division of Satara the programme of afforestation and rehabilitation of degraded forest with participation of private sector through involvement of NGOs and Forest Department as per the directives of the Government of India Ministry of Environment and Forest (F. C. Division) vide Ref.No 821/96-FC dated June 7, 1999 and subsequent circular of the Principal Chief Conservator of Forest Government of Maharashtra under circular No./D.O.No.Desk15/14 dated January 31, 2002; and ELD-2011 PK 167/F10 dated -26 June 2015.

Whereas, the Licensee along with the NGO desire to participate and assist the Government in implementing the said Afforestation Programme in the degraded forest land of Satara Division in District Satara and more particularly described in the Schedule A in accordance with the Government Programme for Afforestation/ Rehabilitation of the degraded forest and as approved by the above referred circular of the Government of Maharashtra herein referred to as "the Approved Scheme" that the Government has agreed to do on the terms and conditions hereinafter appearing.

1. In consideration of the Government hereby granting to the Licensee and the NGO permission as mentioned in Clause (2) hereof, the Licensee and the NGO do hereby agree to participate and assist Government in implementing the said Approved Scheme in the Division of Satara and to duly observe and perform the terms and condition herein contained.



**Deputy Conservator of Forest
Satara Forest Division, Satara.**



2. In consideration of the Licensee and the NGO agreeing to participate and assist Government in implementing the said Approved Scheme in the Division of Satara and to duly observe and perform the terms and conditions herein contained, the Government hereby grants unto the Licensee and or the NGO/organization/institute selected after mutual discussion between the Parties and their respective personnel, permission to enter upon the forest land belonging to Government, admeasuring 08 Hectors situated at Jakhinwadi (Survey No.156), Dist.-Satara, (hereinafter referred to as "the Licensed Premises"). In the Circle, Division and Range of Satara and Total Area 08 Hectors will be developed by an NGO/organization/institute selected after mutual discussion between the Parties for the purpose of afforestation and raising plantation thereon strictly in accordance with the Approved Scheme. Total survey area for tripartite agreement is 08 Hectors & effective area for plantation is 08 Hectors therefore fund allocation done for 08 Hectors plantation activities.
3. Subject to the provision in this Agreement, this License shall be effective for a period of seven years starting from **18th September, 2019 (GR No. FLD-2019/Pr.Kr.271/F-10)** unless terminated by the Parties in accordance with the terms and conditions thereof as indicated in clause 6(l) of this Agreement.
4. During the subsistence of this Agreement, the Licensee shall be deemed to be mere Licensee only of the Licensed Premises and as such, shall have license and authority to enter upon the Licensed Premises for the purpose of carrying out afforestation / plantation work in accordance with the Approved Scheme under the said Afforestation Programme and that the actual ownership of the land on which Afforestation / Plantation work is to be carried out by the Licensee shall continue to remain with the Government.
5. The Licensee do hereby for themselves and their respective successors covenant with the Government as follows: -
 - a. The Licensee and the NGO shall carry out activities as set forth in the Statement of Work marked Schedule B and the activities and budget proposed shall be as brought



**Deputy Conservator of Forest
Satara Forest Division, Satara.**



out in Schedule C. Also, the parties contemplate that the Licensee or the NGO may perform additional assignments, each of which prior to commencement must be approved in writing by the parties with the decision of the Licensee being final and binding and detailed in a separate Statement of Work incorporating this Agreement and attached hereto as an Addendum. Such additional Statement of Work when completed and executed by the parties shall be assigned a successive number, beginning with the number 1, such that the first additional Statement of Work shall be labelled Addendum 1, the second shall be labelled Addendum 2, and so on.

- b. The Licensee or the NGO shall not at any time construct any permanent structure other than things mentioned in Schedule B.
- c. Provided however, the Licensee or the NGO may with the prior permission in writing of the concerned Forest Officer at their own cost construct on the Licensed Premises only essential temporary structure for storing seeds, tools, tackles etc. and raising/rearing seedlings. After completion of the Project, it shall be the responsibility of the Licensee to dismantle and remove such temporary structure from the Licensed Premises.
- d. Soon after the coming into force of this Agreement, the Licensee and the NGO shall in strict accordance with the Approved Scheme by the Chief Conservator of Forest, Satara Circle undertake the work of afforestation and develop green belts over the Licensed Premises. The Licensee, the NGO and the Government shall be mutually responsible for the actual afforestation/ plantation/ watering as well as maintenance, conservation, growth thereof.
- e. The Licensee and the NGO shall undertake the afforestation/ plantation work at their own cost purely on voluntary basis without anticipation of any kind of return of profit there from.



[Signature]
**Deputy Conservator of Forest
Satara Forest Division, Satara.**



- f. The Licensee and the NGO shall not make use of the Licensed Premises for any such business or commercial purpose like hotel, farmhouse, and shop or for any other purpose, except for such works permitted under this Agreement.
- g. To make adequate availability of water for Plants, the Licensee or the NGO may, if it deems necessary, construct water tanks, water Bunds, water ponds, trenches, pipeline and irrigation with drip system, soil and water conservation work.
- h. The Licensee and the NGO shall take all the adequate measures for proper development of afforestation/ plantation work carried out at the Licensed Premises and for promoting soil and water conservation including watering and maintaining the plants and watering trees thereon, undertaken from time to time, fertilizer application, plant protection measures with spraying or soil application, and adoption of other silvicultural measures that help in higher productivity and better management. (Ref. Schedule B).
- i. The Licensee and the NGO shall implement the said Afforestation Programme on the Licensed Premises under the supervision and guidance of the concerned Forest Officer or any officer authorized by him in writing and shall abide by all direction, orders, suggestions etc./ given by him from time to time.
- j. The Licensee and the NGO shall permit any Forest Officer to inspect the records of work maintained by the Licensee with respect to the Agreement. The Licensee and the NGO shall comply with the directions, if any, given by such Forest Officer, in respect of the work within reasonable measure.
- k. The Licensee and the NGO shall not at any time cut any tree without previous permission in writing of the concerned Forest Officer which shall not be granted unless the tree is silviculturally matured or is dead or is to be replaced immediately by planting a fresh tree.



**Deputy Conservator of Forest
Satara Forest Division, Satara.**



- l. The Licensee and the NGO shall have no right whatsoever on usufruct derived from the plantation made by the Licensee or the NGO on the Licensed Premises. All such usufructs shall belong to the Government in such manner as it may deem fit.

Provided however that the forest produce shall be utilized for the benefit of the local persons residing in or around nearby forest area as per the rights of local people over the forest land and as per orders to be issued by the Government or the Conservator of Forest from time to time.

- m. The Licensee and the NGO and concerned Forest Officers shall encourage that the people residing in or around the forest area are taken into confidence and their active participation in largest number is sought for implementing the said Afforestation Programme.
- n. On expiry of the period of this Agreement, it shall be deemed to come an end and thereupon. The Licensee and the NGO shall not be entitled to any compensation for any improvement or development work carried out by them on the Licensed Premises or otherwise.
- o. Provided with the mutual consent of the Parties, the Agreement shall be renewed for a term or terms that may be deemed silviculturally necessary or as may be required for other forest conservation purposes under renewed or revised terms of the Agreement as agreed upon by the Parties as per and under the guidelines of the Approved Scheme.
- p. The Licensee and the NGO shall not in any manner whatever assign or transfer to any company or person the Afforestation/ plantation work under the Approved Scheme on the Licensed Premises or the benefit or this license or any part thereof.
- q. The Licensee shall donate the amount approved by its Trustees to the NGO to implement the afforestation/ plantation work.





Deputy Conservator of Forest
Satara Forest Division, Satara.



- r. The Licensee and the NGO shall render to the Government all possible assistance in extinguishing any fire occurring around the Licensed Premises through such fire which may have arisen from the Licensed Premises. The Licensee or the NGO shall keep the records with details of the improvements works carried out by them in the Licensed Premises in such form as may be desired in this behalf by the concerned Forest Officer and shall, on demand, make such records available to any such Forest officer for inspection and checking.
6. (I) If the Licensee or the NGO fails or neglect to carry out afforestation/plantation work on the Licensed Premises strictly in accordance with the Approved Scheme in the Licensed Premises or commits a breach of any of the terms and conditions of the Agreement, Chief Conservator of Forest, Satara Circle shall intimate the Licensee and the NGO of occurrence of such failure/negligence/breach in order to enable the Licensee to correct/rectify the same within a period of 30 (thirty) days. Despite of such opportunity, if the Licensee or the NGO fails to correct/rectify the same, the Chief Conservator of Forest, Satara Circle shall have liberty to terminate the Agreement.
- (II) No order of termination of Agreement shall be made except after giving a notice in writing to the Licensee and the NGO and considering their say, if any. The Licensee reserves right to terminate the Agreement after giving a written notice of at least thirty (30) days in advance. In the event of breach of any of the terms and conditions of this Agreement by the Government, the Licensee has a right to immediately terminate the Agreement.
- (III) In the event of the Agreement being terminated by either Party, no compensation shall be payable by the Government to the Licensee and the NGO on any account whatsoever.



**Deputy Conservator of Forest
Satara Forest Division, Satara.**



7. In case of change in partnership with the NGO due to any reason whatsoever, the Licensee shall have the sole right to select and appoint the new NGO to implement the afforestation work at the site on the same terms and conditions applicable in the Agreement.
8. All disputes and differences whatsoever arising or relating to this License and whether as to the interpretation of any terms and condition of this Agreement or other matter whatsoever, which have been enumerated hereinabove, either during subsistence of the License or at any time thereafter between the Parties hereto shall be amicably settled between the Parties signing this Agreement, failing which the same shall be subject to Arbitration to be carried out in Satara in accordance with the provisions of the Arbitration and Conciliation Act, 1996. Arbitration proceedings shall be conducted by an arbitrator mutually decided by the Parties and shall be in the English language. This Agreement shall be governed by and construed in accordance with the laws of India and the courts at Satara (Maharashtra) shall have exclusive jurisdiction to try any dispute arising out of this Agreement.
9. The stamp duty on this Agreement and its duplicate shall be borne and said by the Licensee.
10. The Licensee and the NGO, at all the time and any circumstances, will abide by all the provisions by all the Forest (Conservation) Act 1980 and Indian Forest Act 1927.
11. Limitation of liability: In no event shall the Licensee be liable for any special, indirect, consequential, or incidental damages, however caused and regardless of theory of liability, arising in any way out of this Agreement.
12. Force Majeure: Neither Party shall incur liability to the other for delay in performance or for failure to perform under this Agreement if due to causes beyond its control, including, but not limited to, acts of God, acts of war, fire, riot, or intervention by any governmental authority, and each Party shall take steps to minimize any such delay.



**Deputy Conservator of Forest
Satara Forest Division, Satara.**



13. The Revenue and Forest Department allows the Licensee to maintain the Licensees' branding signage, banners, etc. in clean and presentable condition and the same will not be removed/razed/destroyed/relocated unless a prior written intimation is sent to the Licensee during the validity of this Agreement.
14. This Agreement contains the entire agreement between the Parties, and supersedes all previous negotiations, letters of intent, letter contracts, writings, agreements and understandings, if any, heretofore had between the Parties with respect to the subject matter hereof. In case of any conflict between any other document and this Agreement, the terms of this Agreement shall prevail.



B. M.
Deputy Conservator of Forest
Satara Forest Division, Satara.

Schedule - A

Circle - Kolhapur Division - Satara Range - Karad

Name of Village - Jakhinwadi

Working Circle - Karad Comptt. : 694

Four boundaries of the area :

- North : Dangat Samaj Vasti (Malkapur MC), Disforest Land
South : Jakhinwadi Reserve Forest (Compt. No. 694)
East : Koyna Vasahat
West : Dangat Samaj Vasti (Malkapur MC), Disforest Land



B. G. M.
**Deputy Conservator of Forest
Satara Forest Division, Satara.**

Schedule-B

Scope of Work

The Scope of Work to be carried out shall be mutually decided by the parties of the Agreement on a yearly basis.

1. Tree Plantation
 - a. Plantation of trees of indigenous varieties as per plan and guidance of Government for every year of the term of the Agreement.

2. Tree Maintenance
 - a. Irrigation
 - b. Plant protection measures
 - c. Fertilizer Management
 - d. Weed Management
 - e. Staking

3. Arrangement of water for tree maintenances
 - a. Cement tank for water storage
 - b. Temporary pipe line to support the water supply
 - c. Installation of irrigation system(Drip)

4. Soil and water conservation work
 - a. Nala bunds
 - b. Percolation tank
 - c. Earthen bunds
 - d. Gabion structures
 - e. Continuous contour trenches and bunds
 - f. Loose boulder structures
 - g. Kolhapur Type Bandhara (KT) etc.



Deputy Conservator of Forest
Satara Forest Division, Satara.





5. Eco-system Development

- a. Plantation of trees / shrubs which create biodiversity
- b. Activity done for attraction of bird, insect and reptiles (e.g. artificial bird nest, bird feeder, honey bees etc.)
- c. Soil improvement activities.

6. Eco-Tourism Activities.

- a. Creation nature trails.
- b. Nature trail plantation

Any work in addition to the above-mentioned scope to be carried out at the afforestation site shall be mutually agreed by the parties with Licensee's decision being final and binding.

For Krishna Institute of Medical Sciences "Deemed to be University", Karad	For Government of Maharashtra, Forest Department, Satara Forest Division,	For Sankalp Samajik Vaa Shaikshanik Sanstha -A-Bhivadi, P-Triptuti, Tal-Koregaon,Dist.-Satara
		
Name: Dr. M. V. Ghorpade	Name: Dr. Bharat Singh Hada	Name: Mr. Santosh Shelar
Title: Registrar, KIMSDU	Title: Dy.C.F. Satara	Title: Managing Trustee
Date: /12/2019	Date: /12/2019	Date: /12/2019



**Deputy Conservator of Forest
Satara Forest Division, Satara.**



Confederation of Indian Industry

Membership Certificate

This is to certify that

Krishna Institute of Medical Sciences, Deemed to be University

is an Annual Member of Indian Green Building Council (IGBC)

bearing Membership No IGBCIST190356

this certificate shall be valid up to December 2019

K S Venkatagiri
Executive Director
CII - IGBC

V Suresh
Chairman
Indian Green Building Council

Gurmit Singh Arora
Vice Chairman
Indian Green Building Council

Indian Green Building Council

CII - Solihabji Godrej Green Business Centre, Survey No. 64, Near Hitech City, R R Dist, Hyderabad - 500 084
T: +91 40 4418 5132/33 F: +91 40 4418 5189 E: igbc@cii.in W: igbc.in



Confederation of Indian Industry

Membership Certificate

This is to certify that

**Krishna Institute of Medical Sciences,
Deemed to be University**

is an Annual Member of Indian Green Building Council (IGBC)

Bearing Membership No IGBCIST190356

This certificate shall be valid up to December 2021

KS Venkatagiri
Executive Director
CII - IGBC



V Suresh
Chairman
Indian Green Building Council

Gurmit Singh Arora
Vice Chairman
Indian Green Building Council



Indian Green Building Council
CII - Sohrabji Godrej Green Business Centre, Survey No. 64, Near Hitech City, R R Dist, Hyderabad - 500 084
T: +91 40 4418 5132/33 F: +91 40 4418 5189 E: igbc@cii.in W: igbc.in

Krishna Hospital and Medical Research Centre was ranked 1st as a Clean Hospital in "Swachh Sarvekshan 2020" among the Hospitals in Malkapur Nagarparishad, Tal. Karad, Dist. Satara.

स्थापना : २४ सप्टेंबर २०१८

 **मलकापूर नगरपरिषद, जि. सातारा**
ता. कराड, जि. सातारा. पिन कोड नं. ४१५ ५३९
☎: कार्या. : (०२१६४) २४१३२४, २४१३३२, ई-मेल : malkapur np2008@gmail.com

जाचक क्र. : ३७७२/१ दिनांक : २९ / ०६ / २०१९

  

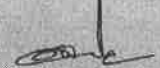

स्वच्छ सर्वेक्षण २०२०
स्वच्छ हॉस्पिटल गौरव प्रमाणपत्र

मलकापूर नगरपरिषद, जि. सातारा यांचेकडून प्रमाणपत्र देणेत येते की, स्वच्छ सर्वेक्षण २०२० अंतर्गत शहरातील सर्व हॉस्पिटल यांचे स्वच्छता बाबतीत सर्वेक्षण करणेत आले असून त्यामध्ये कृष्णा हॉस्पिटल अॅण्ड मेडिकल रिसर्च यांनी स्वच्छते बाबतच्या सर्व बाबी पूर्ण करून प्रथम क्रमांक प्राप्त केलेबाबत हे प्रमाणपत्र देऊन गौरविण्यात येत आहे.

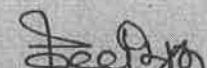
श्रीमती संजीवनी दळवी
मुख्याधिकारी
मलकापूर नगरपरिषद, जि. सातारा

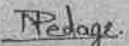
श्री. मनाहर भास्करराय शिंदे
उपनगरस्थळा ताचा सभापती
मलकापूर, ता. कराड, जि. सातारा
मलकापूर नगरपरिषद, जि. सातारा

श्री. निलम चंनंजय येडगे
नगराध्यक्ष
मलकापूर नगरपरिषद, जि. सातारा

 **स्वच्छ, सुंदर, व हरित मलकापूर** 

English Translation

MALKAPUR NAGAR PARISHAD, DIST. SATARA.

TALUKA KARAD, DISTRICT SATARA.

PIN CODE No. 415 539.

Phone : Office – 02164 241324, 241332.

E-mail malkapurnp2008@gmail.com.

Established- 24-Sept-2018.

CLEAN SURVEY 2020

CERTIFICATE FOR CLEAN HOSPITAL HONOUR

Certificate is issued from Malkapur Nagar Parishad, District Satara, that survey of cleanliness in all the hospitals within city is conducted. During that process, Krishna Hospital and Medical Research, has fulfilled all aspects of cleanliness and got 1st number, hence it is honoured by issuing this certificate.

Sd/-

Smt.Sanjivani Dalvi
Chief Officer
Malkapur Nagar
Parishad, District Satara.

Sd/-

Shri. Manohar Bhaskarrao Shinde
Vice President and President,
Water Supply, Public Health, and
Water Expulsion Samiti, Malkapur
Nagar Parishad, District Satara.

Sd/-

Sou. Nilam Dhananjay
Yedge
President, Malkapur Nagar
Parishad, District Satara.



REGISTRAR
Krishna Institute of Medical Sciences
"Deemed To Be University", Karad



ENERGY AUDIT REPORT

(September 2016)

Prepared For

Krishna Institute of Medical Sciences Deemed University

Malakapur, Pune-Bangalore Highway, Tal.: Karad, Dist.: Satara
Pin Code : 415 539, State : Maharashtra, Country : India

Prepared By

Green Scientific Development (I) Pvt. Ltd.

4/ 'A' Wing, Bldg. No. 23, Tulsi C.H.S. Ltd., Subhash Nagar,
Chembur, Mumbai, Pin Code: 400 071, Maharashtra, India
Email : greenscientificdevelopment@gmail.com

REGISTRAR
Krishna Institute of Medical Sciences
"Deemed To Be University", Karad

TABLE OF CONTENTS

1	CERTIFICATE	01
2	PREFACE.....	02
3	ACKNOWLEDGEMENT	03
4	ABBREVIATIONS	04
5	EXECUTIVE SUMMARY.....	05
6	BASIC DETAILS	06
7	INTRODUCTION	07
	7.1 Preamble	07
	7.2 Objectives	07
	7.3 Scope of Work	07
	7.4 Methodology.....	08
8	ENERGY PERFORMANCE ASSESSMENT AND SAVINGS OPPORTUNITIES.....	10
	8.1 Electricity Consumption	10
	8.1.1 Electricity Consumption from Grid.....	10
	8.1.2 Electricity Generation using DG Sets	11
	8.2 Regression Analysis.....	12
	8.3 Air Compressor.....	13
	8.4 Lighting System (Indoor & Outdoor)	16
	8.5 Hot Water Generation	17
	8.6 Air Conditioning System	20
	8.7 Findings	23
	8.8 Recommendations.....	24
	8.9 Generalised Energy Conservation Tips	26
	8.9.1 Electricity.....	26
	8.9.2 Motors	26
	8.9.3 Drives.....	27
	8.9.4 Fans	27
	8.9.5 Compressors.....	27

8.9.6	Pumps.....	28
8.9.7	Blowers	28
8.9.8	Compressed Air.....	29
8.9.9	Chillers.....	30
8.9.10	Refrigeration	30
8.9.11	HVAC	31
8.9.12	Cooling Towers.....	32
8.9.13	Lightings	33
8.9.14	D G Sets	33
8.9.15	Buildings	33
8.9.16	Waste & Waste Water.....	34
8.9.17	Miscellaneous	35

LIST OF TABLES

Table 1. Electricity Consumption (2015).....	10
Table 2. Diesel Consumption (2015).....	11
Table 3. Cooling Degree Days (2015).....	12
Table 4. Air & Vacuum Compressor Details.....	13
Table 5. Air Dryer Details	14
Table 6. Arrestation of compressed air leakages in the system	14
Table 7. Cut Off pressure reduction instead of Pressure Reducing Valve	16
Table 8. Replacement of existing lightings system with LEDs	16
Table 9. Hot Water Requirements.....	17
Table 10. Solar Evacuated Tube Water Heater.....	18
Table 11. Heat Pump for Hot Water Generation.....	19
Table 12. Replacement of Split/Window ACs with VRV System.....	20
Table 13. Replacement of Split/Window ACs with 5 Star inverter split ACs.....	21
Table 14. Electronics Savers for Split/Window ACs.....	22

LIST OF FIGURES

Figure 1. Electricity Consumption (2015)	10
Figure 2. Regression – Electricity vs. CDD.....	12
Figure 3. Ultrasonic Compressed Air Leakage Detection	14
Figure 4. Artificial Demand of Air Compressor.....	15
Figure 5. Solar Evacuated Water Heater.....	18
Figure 6. Heat Pump	19

I CERTIFICATE

This is to certified and declared that the Energy Audit Report is prepared for “Krishna Institute of Medical Sciences Deemed University”(KIMSDU), Satara, Maharashtra on a best efforts, judgment & good practice basis by “Green Scientific Development (I) Pvt. Ltd. (GSDIPL), Mumbai.

The details contained in this report have been compiled in good faith based on the basis of information provided & shared by Krishna Institute of Medical Sciences Deemed University, Karad and site visit sampling and observation. We further submit that the projections are the management’s best estimates and no representation, warranty or undertaking, express or implied is made. We further, no responsibility is accepted by Green Scientific Development (I) Pvt. Ltd and/or its affiliates and/or its Directors, auditors in this report or for any direct or consequential loss arising from any use of the information, statements or forecasts in the report.

[Signature]
CS.V.KALE

Energy Auditor
(Certificate No. EA 4593)
Mr. Shripad Vishnu kale

[Signature]

Energy Manager
(Certificate No. 6827)
Mr. Bhalchandra Shridhar Bhurke

[Signature]
10/5/2016

Director, GSDIPL
EMS ISO 14001 Lead Auditor
Mr. Kiran Mahadev Shinde

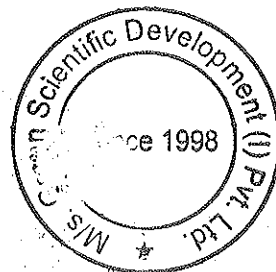

2 PREFACE

Krishna Institute of Medical Sciences Deemed University appointed Green Scientific Development (I) Pvt Ltd to conduct Energy Audit for checking levels of energy aspects and suggest for the improvement at the KIMSDU, Karad.

In the State Maharashtra district Satara Krishna Institute of Medical Sciences Deemed University (KIMSDU) is a medical education institute offering undergraduate degree and diplomas for post-graduation in various branches of medical sciences. Krishna hospital is committed to provide standard treatments and quality care. Management of Institute is well aware for sustainable development of institutional premises.

The energy audit is aimed to record, quantification energy levels/consumption, refer available records, facts and to explore the possibilities of conserving of energy through better practices.

This report contents the performance assessment& Saving Opportunity, suggestions so that the management can take up the implementation according to investment and payback priorities.

3 ACKNOWLEDGEMENT

This Energy Audit is conducted by GSDIPL for KIMSDU hand in hand with appointed institutional representative & staff with all possible efforts on energy aspect for the Hospital and Premises.

The institutional team had put there all possible involvement to accomplish the task, without which it would not be possible to accomplish satisfactorily.

The common goals kept for accounting & contain energy usage without sacrificing the purpose of use of energy at its optimum requirement.

We are thankful to the Top Management of Institute for appointing us to conduct energy audit & also further thankful for the contribution from ;

Mr. (Dr.) M. V. Ghorpade - Registrar

Mr. Sataynaryan Mashalkar - Asstt. Registrar

Mr. Yogesh Kulkarni - Electrical Engg.

4 ABBREVIATIONS

Abbreviations	Full Form
Asstt.	Assistant
A	Ampere
AC	Alternating Current
AC's	Air Conditioner
Avg.	Average
°C	Degree Centigrade
COP	Co-Efficient Of Performance
DC	Direct Current
Eff.	Efficiency
GSDIPL	Green Scientific Development (I) Pvt. Ltd.
HVAC	Heating Ventilation and Air Conditioning
HP	Horse Power
KIMSDU	Krishna Institute of Medical Sciences Deemed University
KV	Kilo Volt
KvA	Kilo Volt Ampere
kW	Kilo Watts
Kwp	Kilo Watts Power
LPD	Liters Per Day
M or m	Meter
m/c	Machine
Min.	Minimum
mm	Millimeter
MSEDCL	Maharashtra State Electricity Distribution Company Ltd.
PRV	Pressure Reducing Valve
RH	Relative Humidity
Sec.	Second
SPV	Solar Photovoltaic
SWH	Solar Water Heater
THD	Total Harmonic Dispersion
V	Voltage
VFD	Variable Frequency Drive
VRV	variable refrigerant valve

5 EXECUTIVE SUMMARY

Review - Energy Saving Started from Sept 2015 are summarised below

Sr. No	Description	Saving / kWh
1	39 Watt LED Light, Qty - 21 From Sept 2015, Saving	13097
2	Solar System 10 Kwp from Oct 2015, Saving	13096
3	Energy Efficient 750 Kva trans, Install, May 2016 Saving	8212
4	Installation of APFC Panel, May 2016, Saving	103500

The major potential savings along with investment and payback period are given below.

Sr. No.	Energy Conservation Measures	Annual Savings		Investment (Rs. Lakhs)	Simple Payback Period (Months)
		Electricity (kWh)	Rs. Lakhs		
1	Arrestation of compressed air leakages in the system	12958.2	0.91	NIL	Instant
2	Cut-off pressure reduction instead of Pressure Reducing Valve	2407.13	0.16	NIL	Instant
3	Replacement of existing lighting system with LEDs	326700	22.00	-	< 08
4	Use of Solar Evacuated Tube Water Heater for Hot Water Generation	111714.8	7.82	-	36-48
5	Use of Heat Pump for Hot Water Generation	72242.3	5.06	-	12-24
6	Replacement of existing split/window ACs with VRV system	112054	7.84	-	12-24
7	Replacement of existing split/window ACs with 5-star inverter split ACs	241210	16.88	-	36-48

6 BASIC DETAILS

Name of institution	Krishna Institute of Medical Sciences Deemed University
Location	Malakapur, Pune - Banglore Highway, Karad - 415 539, Maharashtra, India
Year of Establishment	1984
Activity	Medical Education
Facility	Medical College, Hospitals
Energy Scene	
Major Connected load	Air & Vacuum Compressors, Ovens, AC Units, Lighting, Pumps, Computers, Medical & Other Office Equipment, etc.
Major Energy Sources	Electricity from the Grid
Energy Audit Date	16 September 2016

7 INTRODUCTION

7.1 Preamble

- ✓ With the aim of knowing energy aspects KIMSDU management appointed GSDIPL for the energy audit of KIMSDU.
- ✓ KIMSDU has a facility at Karad, Satara. The Institution is facilitated with the utilities like AC's, Lighting, Geysers, Boilers, Medical Equipment's & office equipment's.
- ✓ This energy audit report for KIMSDU, Karad campus presents data collection, Analysis, Field trials, Observations, Recommendations & General Tips

7.2 Objectives

- ✓ To undertake an energy audit through certified person so as to know & identify areas for energy saving

7.3 Scope of Work

- ✓ To correlate monthly data of for a period of 12 months of normal operation.
- ✓ To study electrical energy monitoring and control system existing at the institute
- ✓ To recommend a suitable system for future monitoring.
- ✓ To study energy aspect for the reference period along with monthly electricity consumption and establish scope for MD control through possible optimization of load factor and through detailed load management study.
- ✓ To undertake a detailed motor load study on major continuously operating motors with the help of a clamp on multi-meter to identify instantaneous motor parameters.
- ✓ Based on above, to evaluate the possibility of replacing major motors with energy efficient motors.
- ✓ To study compressed air & nitrogen distribution system in the plant, in terms of compressor type, make, capacity, loading, motor type / size / loading etc. and to undertake output efficiency test for the operating compressors.
- ✓ To study existing requirements of chilled water/conditioned air provisions at present locations and to identify distinct possibilities of rationalization /savings.
- ✓ To study operation of chilled water/conditioned air with the help of operating records kept and spot measurements taken during the field study and identify COP for chilling compressors in usage and identify scope for optimization through improved operating / maintenance practices.
- ✓ To study existing maintenance practices for chilled water / air conditioning system and recommend areas for improvement in energy efficiency /savings.

- ✓ To identify, evaluate and priorities energy saving opportunities into short, mid and long- term time spans depending upon investments, quantum of savings, skills and time required for implementation, etc
- ✓ To recommend a time-bound action plan for implementation of accepted measures.
- ✓ To prepare draft energy audit report, present to management, undertake necessary modifications based on presentation meeting and submit the final report.

7.4 Methodology

Audit Team

GSDIPL proposed a team of experts for conducting the study and worked in close association with KIMSDU unit personnel.

External

Energy Auditor : Mr. Shripad Kale - BEE Certified Energy Auditor
 Energy manager : Mr. Bhurke Bhalchandra - BEE Certified Energy Manger

Internal

KIMSDU : Mr. Yogesh Kulkarni - Electrical Engineer

Documentation

GSDIPL submitted a work plan, checklist to the KIMSDU representative, KIMSDU provided relevant data& Documents, Nominated responsible person by KIMSDU who is involved in energy aspect, sections along with his staff in day to day activity for achieving objective of Audit.

Field Work

GSDIPL undertook an "OPENING MEETING" with all related team and then GSDIPL's team conducted all necessary field trials and measurements, GSDIPL provided all the instruments (List No 1) necessary for conducting the Field trials, Closing Meeting – On table Discussion conducted about field trial and its findings.

Report

- Drafting of Report and its verification by management representative
- Final report submission to the management

List 1: List of the Instruments Used for Measurement

Instrument Name	Specification
Demand Analyzer	Suitable for electrical parameters like voltage, current, frequency, harmonics, active & reactive power, power factor etc.
Clamp-on Power Meter	0 - 1200 kW 0 - 600 Voltage, AC 0 - 800 Voltage, DC 0 - 2000 A, Current, AC / DC
Power Quality Analyzer	3 Ph. 4 Wire Recording Parameters: Voltage, Current, Frequency, Harmonics/ Inter harmonics up to 50 th , THD of V, I and KW with K Factor, Transients Voltage, All Power Parameters, Inrush current, Flicker Recording, Graphical, Vectorial, Numeric representation, trending of data, monitoring of events, etc.
Lux Meter	0 - 50,000 lux level (Non-Contact Type)
Digital Thermal Anemometer	0 - 45 m/sec. 3%
Relative Humidity and Temperature Indicator	RH – 10% to 95% Temp. – 0 to 100 °C
Infrared Thermometers	40 °C to 500 °C
Portable Temperature Indicator	50 °C to 1200 °C
Stop Watch	Standard

8 ENERGY PERFORMANCE ASSESSMENT AND SAVINGS OPPORTUNITIES

8.1 Electricity Consumption

8.1.1 Electricity Consumption from Grid

A study was conducted to observe the variations in the electricity consumption for the past years. The details of the same are given below.

Table 1. Electricity Consumption (2015)

Sr. No	Month	2015
1	Jan	2,45,929
2	Feb	2,45,422
3	Mar	3,22,926
4	Apr	3,41,002
5	May	3,55,948
6	Jun	3,27,814
7	Jul	3,11,106
8	Aug	3,15,782
9	Sep	3,10,796
10	Oct	3,39,025
11	Nov	2,82,100
12	Dec	2,82,363
Total		36,80,213

Electricity Consumption Comparison (2015)

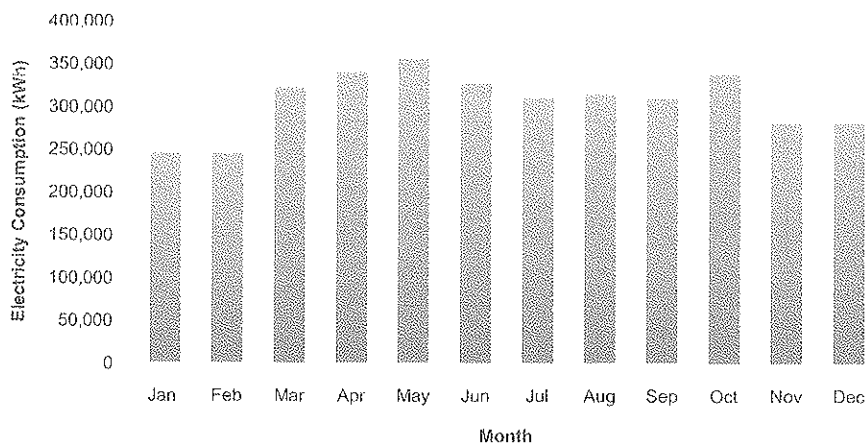

Figure 1. Electricity Consumption (2015)

From the above data, it can be seen that;

- ✓ The minimum electricity consumption was in the month of February because of reduction of cooling load during the month.
- ✓ The maximum consumption is during the month of May because of the high cooling demand.

8.1.2 Electricity Generation using DG sets

During power outage, DG sets were used as a backup option. The diesel consumption month-wise for the year of 2015 given below.

Table 2. Diesel Consumption – 2015

Month	2015
Jan	600
Feb	400
Mar	600
Apr	800
May	400
Jun	800
Jul	300
Aug	1000
Sep	1400
Oct	800
Nov	400
Dec	1200
Total	8700

8.2 Regression Analysis

Heating and Cooling degree days (HDD/CDD) are used to indicate the effect of outside air temperature on building energy consumption during a specified time. They represent the number of degrees and the number of days that the outside air temperature at a specific location is lower/higher than a specified base temperature. Since the buildings are air-conditioned and no heating is involved, only CDD have been considered as independent variables.

The relationship between electricity consumption and cooling degree days is represented by the equation $y = mx + c$, alphabct 'y' represents energy consumption plotted on the y-axis and 'x' represents cooling degree days plotted on the x-axis. The slope of the line 'm' represents degree by which energy consumption varies corresponding to a rise of 'x' degree days. Constant 'C' is known as baseload, which is considered to occur as a constant load and is independent of the number of degree days or sales or footfall. R^2 is the coefficient of determination of the model & if its value is above 0.75, then the model is considered to correlate considerably with the independent variable.

Table 3. Cooling Degree Days (2015)

Month	J	F	M	A	M	J	J	A	S	O	N	D
Cooling Degree	2.05	32.31	113.89	148.51	171.98	53.82	22.97	12.4	11.53	41.54	13.06	13.3

Monthly data for cooling degree days (CDD @ 24°C) and electricity consumption for the year January 2015 – December 2015 is shown in Table above. The CDD with a base value of 24°C is selected because the majority of the cooling load is for human comfort condition

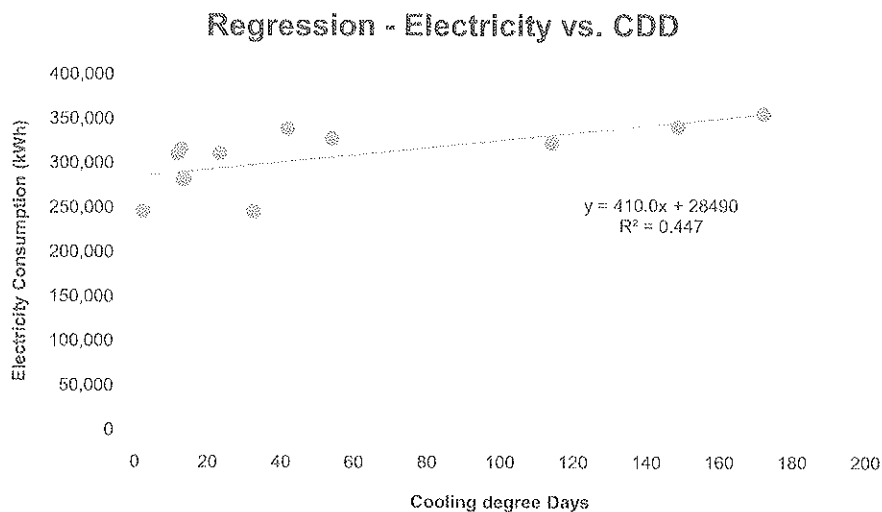

Figure 2. Regression – Electricity vs. CDD

The R^2 (coefficient of determination) value for the regression model is approximately 44.76%, this signifies that the weather (CDD) does not show any strong correlation with the electricity consumption of the facility.

It can be seen from the above figure that the electrical consumption does not comprise only of HVAC systems. However, it has been observed that the major connected load is HVAC systems comprising of approximately 1272 kW. So, there is a possibility of inefficiency in the HVAC systems which is indicated by the lower value of R^2 .

8.3 Air Compressor

Air Compressor is one of the energy intensive equipment in the whole premise. It is known that only about 10% of the input energy to the compressor is converted to useful compressed air energy. Performance of the air compressor is of great importance and a significant amount of energy savings can be achieved from it.

In determination of air compressor performance, Free Air Delivery of the compressor is carried out. Presently, there are 2 air compressors present in KIMSDU Dental College & Clinic. During the weekdays, the larger capacity compressor is used for approximately 10 hours. The lower capacity compressor is used only on Saturday. Following is the data of the existing air compressors and air dryer in the college and clinic.

Table 4 (a). Air Compressor Details

Parameters	Units	Comp. 1	Comp. 2	Comp. 3	Comp. 4	Comp. 5	Comp. 6
Equipment no.	-	AC 01	AC 02	AC 03	AC 04	AC 05	AC 06
Make	-	Ingersoll Rand	Ingersoll Rand	Ingersoll Rand	Ingersoll Rand	KFC	Elgi
Type	-	Screw	Screw	Reciprocating	Reciprocating	Reciprocating	Reciprocating
Capacity	HP	40	10	10	7.5	1.0	5.0
Motor Power	kW	22	11	7.5	5.5	0.75	3.7
Total Current	A	43	23	11	8	0.5	5.2

Table 4 (b). Vacuum Compressor Details

Location of Vacuum Compressor	Equipment No	Make	Type	Capacity (HP)	Motor Power (Kw)	Total Current (A)
Ward No 21 to 28	VC 01	Ingersoll Rand	Reciprocating	10	7.5	13
Ward No 21 to 28	VC 02	Ingersoll Rand	Reciprocating	10	7.5	13
CVTS	VC 03	Ingersoll Rand	Reciprocating	10	7.5	13
Operation Theatre	VC 05	Ingersoll Rand	Reciprocating	05	3.7	8
OT	VC 06	Ingersoll Rand	Reciprocating	02	1.5	2.6
CASUALITY	VC 07	Ingersoll Rand	Reciprocating	02	1.5	2.6
ICU	VC 08	Ingersoll Rand	Reciprocating	02	1.5	2.6

Table 5. Air Dryer Details

Sr. No.	Parameters	Units	Compressor 1
1	Cooling Fluid	-	R 22
2	Max. Temperature	°C	60
3	Max. Ambient Temperature	°C	50
4	Max. Inlet Pressure	barg	14

Another important part of the air compressor and its system is the leakages present in the compressed air distribution and utilization system such as Pipeline, joints, end applications, etc. As we already know that 90% of the input energy to the compressor is wasted, leakages in the system will waste a significant amount of energy. A normal and healthy compressed air system consists of leakages of a quantity of maximum of 8 to 10% of the compressor rated quantity.

Energy Savings Recommendations:

1. Energy Savings due to arrestation of compressed air leakages in the system

During the audit, many air leakages were observed in the compressed air system. Assuming the diameter of the leak to be 1 mm at 7.5barg air pressure, the air leakage is approximately equal to 2.3cfm. Considering the specific energy consumption of the air compressor to be 0.18 kW/cfm. The power losses due to 10 leakages of 1 mm diameter is given below.

Table 6. Arrestation of compressed air leakages in the system

Sr. No.	Parameters	Units	Values
1	Diameter of leakage	mm	1
2	Pressure of Air	barg	7.5
3	Number of Leakages	nos.	5
4	Air flow through a single leak point*	cfm	2.3
5	Specific Energy Consumption of Air Compressor	kW/cfm	0.18
6	Total power losses due to leakages	kW	2.07
7	Daily Operating Hours	hours	10
8	Annual Working Days	days	313
9	Annual Energy Savings	kWh/year	6,479
10	Electricity Tariff	Rs./kWh	9.25
11	Annual Cost Savings	Rs./year	59930

*<https://www.tlv.com/global/TL/calculator/air-flow-rate-through-orifice.html>

In actual, the quantity of the leakages will be more and the diameter of the leakage might be less or more. However, it is also recommended to conduct a detailed online compressed air leakage detection of the whole plant. This audit is conducted using Ultrasonic Leak Detector which detects ultrasonic sound released by small leakages which are unheard by a human.

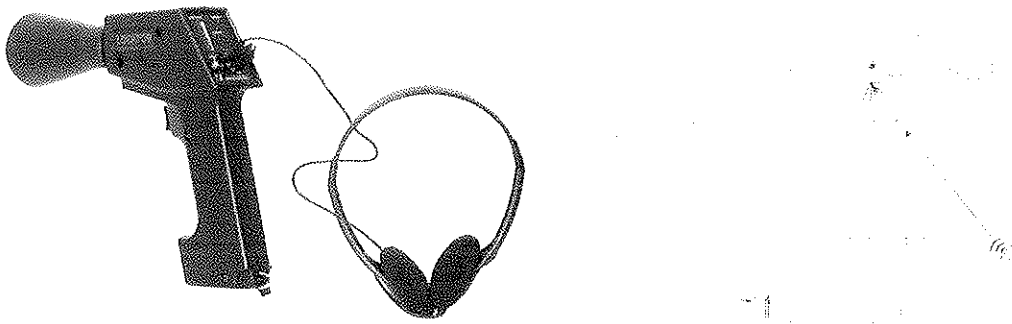

Figure 3. Ultrasonic Compressed Air Leakage Detection

2. Cut-off pressure reduction instead of Pressure Reducing Valve

Artificial demand of the compressors is the additional volume of air which is required because of end uses where air is not regulated, which is the result of supplying the air at a higher pressure than required for any application. Artificial demand increases the supply pressure which directly increases the power consumption of the air compressors.

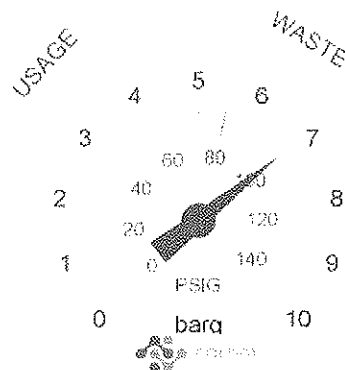

Figure 4. Artificial Demand of Air Compressor

Presently, the cut-off pressure of the larger capacity air compressor is 7.8 kg/cm^2 . The required air pressure is less than 6.5 kg/cm^2 . Reduction of the cut-off pressure from 7.8 to 7 kg/cm^2 will give a significant amount of savings. Presently, the pressure reduction is done using a pressure reducing valve which is not a good energy efficiency practice. Savings due to the reduction of cut-off pressure of the compressor is given below.

Table 7. Cut-off pressure reduction instead of Pressure Reducing Valve

Sr. No.	Parameters	Units	Values
1	Cut-off Pressure	bar (g)	7.8
2	Proposed unloading pressure	bar (g)	7
3	Proposed loading pressure	bar (g)	6.5
4	Power consumption after reducing the cut-off pressure by 1 bar (g)	%	3
5	Power reduction due to reduction of cut-off pressure by 0.8 bar (g)	%	2.4
6	Present daily consumption**	kWh	96.07
7	Daily Operating Hours	hours	9
8	Annual Working Days	days	313
9	Annual Energy Savings	kWh/year	6495
10	Electricity Tariff	Rs./kWh	9.25
11	Annual Cost Savings	Rs./year	60078

**As per Bureau of Energy Efficiency*

***Assuming 70% loading of the air compressor*

8.4 Lighting System (Indoor & Outdoor)

Lighting is the other important system present in the premise which is highly energy intensive. Fluorescent tubelights and CFL were observed commonly in the facility. The facility has already replaced these lights with energy efficient tubelights.

Energy Savings Recommendations:

- **Replacement of existing CFL and Fluorescent tubelights with LEDs**

However, there is still a scope of replacement of the remaining CFL and tubelights with LEDs. Direct reduction in power consumption by 40% is achieved with the replacement. This will also reduce the maximum demand of the whole plant by the same amount. As LEDs are semi-conductor devices, there is also a reduction in power factor improvement capacitor requirements in the facility.

Table 8. Replacement of existing lighting system with LEDs

Sr. No.	Parameters	Units	Values
1	Approximate power savings	kW	14
2	Daily Operating Hours	Hours	10
3	Annual Operating Days	days	313
4	Electricity Tariff	Rs./kWh	9.25
5	Annual Electricity Savings	kWh	43,820
6	Annual Cost Savings	Rs./year	4,05,335

8.5 Hot Water Generation

Hot water is required in the whole facility for different purposes like bathing, cooking and washing. Presently, there is no provision of central hot water system. Instead, different electric heaters are available. Hostels, VIP Rooms, Hospital building and canteen are the locations where hot water is required. The present hot water requirement based on the geyser capacity is given below.

Table 9. Hot water requirements

Geysers Capacity (litres)	Quantity	Total Capacity (litres)
6	30	180
10	22	220
15	4	60
25	4	100
35	5	175
50	60	3000
100	4	400
Total	129	4035

Based on the total geyser capacity, total hot water generation = 4035 litres. Considering an additional usage of water giving a total of 8075 litres. Assuming this value of hot water required throughout the day.

Energy Savings Recommendations:

- **Use of Solar Evacuated Tube Water Heater for Hot Water Generation**

Solar water heating will generate hot water free of cost with only a small power consumption of the feed water pump. Initial investment will be a little high. However, after the payback period is over, free hot water will be generated without any consumption of electricity. For generation of 8075 litres of hot water every day, following is the energy savings achieved using solar water heater.

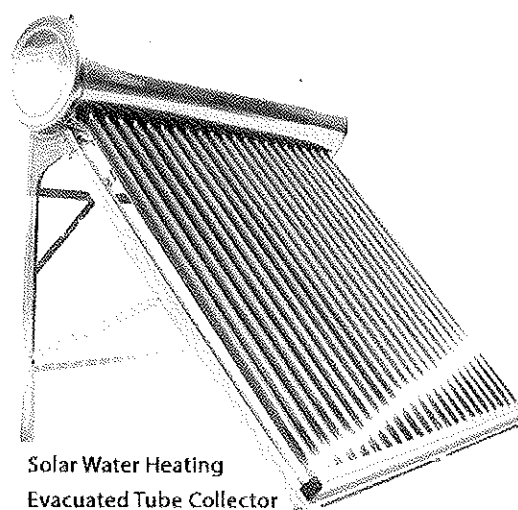

Figure 5. Solar Evacuated Water Heater

Table 10. Solar Evacuated Tube Water Heater

Sr. No.	Parameters	Units	Values
1	Hot water required @ 55°C	litres/day	8075
2	Annual Solar Radiation Incident	kWh/m ² -year	1748.62
3	Annual Thermal Energy required for 7011 litres hot water	kWh/year	1,08,363.4
4	Thermal Efficiency of Solar Water Heater	%	65
5	Maximum Area of Solar Water Heater required	m ²	516.1
6	Annual Power Consumption of Geysers with 97% efficiency of geyser	kWh/year	1,11,714.8
7	Annual Cost savings with replacement	9.25 Rs./year	10,33,362

- **Use of Heat Pump for Hot Water Generation**

Another alternative to the generation of hot water to solar water heater is a Heat Pump. Heat pump is similar to a refrigerator in construction. The only difference is that the hot side of the system is utilised in a heat pump to supply heat to a space, whereas the cold side of the system is utilised in a refrigerator to remove heat from a space. The electrical energy input to the heat pump is less than the thermal energy output because of its working cycle principle which is represented by COP. COP of a heat pump is the ratio of Thermal Energy supplied to the Electrical Energy Input. Therefore, for the same amount of heat supply, the energy input is lesser than electrical heater/geyser.

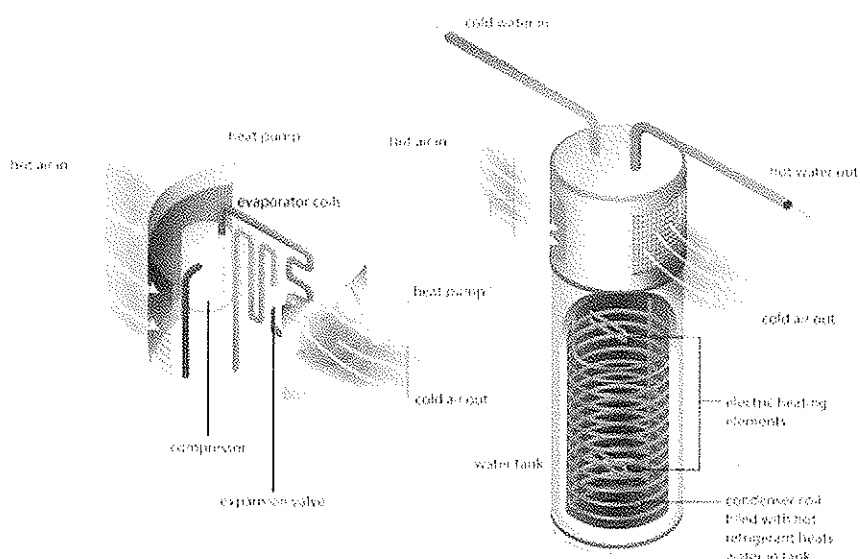

Figure 6. Heat Pump

A centralised heat pump system can be installed for meeting the hot water requirement of the whole facility or individual heat pump units can be installed for each building. The savings associated with the use of heat pump for hot water generation is given below.

Table 41. Heat Pump for Hot Water Generation

Sr. No.	Parameters	Units	Values
1	Hot water required @ 55°C	litres/day	8075
2	Annual Thermal Energy required for 7011 litres hot water	kWh/year	1,08,363.4
3	Annual Power Consumption of Geysers with 97% efficiency of geyser	kWh/year	1,11,714.8
4	COP of a Heat Pump	-	3
5	Annual Electrical Energy input of Heat Pump	kWh/year	36,121.1
6	Annual electrical energy savings	kWh/year	72,242.3
7	Electricity Tariff	Rs./kWh	9.25
8	Annual Cost Savings	Rs./year	6,68,241

A combined system consisting of Solar Evacuated Water Heater along with Heat Pump can be used, thus optimising both renewable as well as energy efficient technology.

8.6 Air Conditioning System

Different buildings in the facility have split/window and duct-able air conditioning units. These air conditioners being smaller ratings have little scope unlike centralized chillers for applying means of energy saving like use of VFDs on AHUs and secondary pumps.

Present day VRF systems which are energy efficient find use only when the interiors are pre-designed according to the VRF requirements.

Presently, VRV system of 148 HP is installed in the facility. However, medical college building and library area have split/window ACs. Also, some of the window/split ACs installed are with low BEE star rating.

Energy Savings Recommendations:

- **Replacement of existing split/window ACs with VRV system**

Replacement of existing split/window ACs with a VRV system of an equal size will give energy savings. The amount identified for the replacement of the AC is 210 HP which can be replaced with an equal amount of VRV system. The energy savings achieved with the same is given below.

Table 52. Replacement of Split/Window ACs with VRV system

Sr. No.	Parameters	Units	Values
1	Approximate power savings	kW	35.8
2	Daily Operating Hours	Hours	10
3	Annual Operating Days	days	313
4	Electricity Tariff	Rs./kWh	9.25
5	Annual Electricity Savings	kWh	1,12,054
6	Annual Cost Savings	Rs./year	10,36,499

- **Replacement of existing split/window ACs with 5-star inverter split ACs**

Existing split/window ACs can be replaced with 5-star inverter split ACs. Assuming presently all the split/window ACs are 3-star rated. The energy savings associated with the replacement of the same is given below.

Table 136. Replacement of Split/Window ACs with 5-star inverter split ACs

Sr. No.	Parameters	Units	Values
1	Existing 3-star split AC ISEER	-	3.55
2	5-star split inverter AC ISEER	-	4.75
3	Annual energy savings	%	25
4	Present split/window AC capacity	TR	228
		kW	228
5	Power savings	kW	57
6	Daily Operating Hours	Hours	10
7	Annual Operating Days	days	313
8	Electricity Tariff	Rs./kWh	9.25
9	Annual Electricity Savings	kWh	178410
10	Annual Cost Savings	Rs./year	16,50,292

- **Retrofit of Electronic Savers for Split ACs**

Electronic savers consist of electronic controls which control the operation of the compressor with an additional thermostat. The thermostat which comes in-built the AC provides only a rough control of the temperature setting, which leads to overshoot or undershoot of the set temperature, which results in wastage of energy. When the thermostat fails, the AC works continuously and it is difficult to recognize this failure and take corrective action.

The power saved can be anywhere between 0.2 units per hour to about 1.0 unit per hour depending upon the setting chosen. Savings projected by manufacturers are high (15% to 35%). However, on conservative side if savings are considered to be 20%, payback can be verified. The savings associated with the same is given below.

Table 74. Electronic Savers for Split/Window ACs

Sr. No.	Parameters	Units	Values
1	Present Split/Window AC capacity	TR	236.5
2	Average Power Consumption	kW	307.45
3	Annual Electricity Consumption	kWh/year	2,99,063
4	Savings with Electronic Savers	%	20
5	Annual Electricity Savings	kWh/year	59,813
6	Electricity Tariff	Rs./kWh	9.25
7	Annual Cost Savings	Rs./year	5,53,270
8	Approximate cost of Electronic Saver	Rs.	10,000
9	Total No. of Split/Window units	Nos.	138
10	Approximate Investment	Rs.	13,80,000
11	Simple Payback Period	Years	3.3

8.7 FINDINGS

Various areas for energy conservation are identified, enlisted and overall strategy evolved and discussed with Audit Team and Top management for effective implementation of the recommendations.

Potential Energy Savings & Remarks

Sr. No.	Energy saving Potential	Approximate Saving/year	Remark
1	Saving through Arresting air leakages in compressed air system	10%	Arresting air leakages fully is not practically possible. Air leakages can be effectively reduced to 70% through monitoring and routine maintenance.
2	Pressure reduction in place of PRV The set pressure is 7.8 to 8.0 Kg/cm ² for air compressor. The site fed back was that the actual point of use of compressed air pressure is 6.5 Kg/cm ² .	5%	Instead of reducing the pressure using PRV, it is recommended that the set pressure could be 7.0 Kg/cm ² . Reduction in set pressure will result in reduction in power consumption.
3	PV Solar System There is scope for installation for PV solar System in area.	61 Lakh	Solar energy and area is available for PV solar system. Near about 500 Kwp PV solar system can be install.
4	Lighting is main consumption in Electrical System and Most of the light fittings are CFL and FTL.	28 Lakh	There is scope to convert near about 4500 Nos. of light fitting (180 Kwh) into LED fitting. Change light fitting into LED light fitting.
5	VRV system. VRV system is good option for Air conditioning System.	20 % against regular AC	Near about 150 HP VRV system can be installed.
6	Replacement of old AC with new Star rated and inverter AC.	10%	Replacement of 5 star rated AC with old AC will give near about 10 % saving

8.8 RECOMANDATIONS

Following suggested implementation priority can be adopted.

1. Saving through Arresting Leakage Losses

- System leakages are common to both the compressors. The absolute quantity however will be in proportion to the CFM (FAD) capacity of the compressors.
- Arresting air leakages fully is not practically possible. Air leakages can be effectively reduced to 70% through meticulous routine maintenance.

2. Pressure Reduction

- The set pressure is 7.8 to 8.0 Kg/cm² for 22 KW air compressor that can be verified from display of the compressor and also pressure gauge dial on the receiver tank. The site fed back was that the actual point of use of compressed air deploys P.R.V. to reduce the pressure to 6.5 Kg/cm². The difference is about 1.3 Kg/cm² to 1.5Kg/cm².
- Instead of reducing the pressure using PRV, it is recommended that the set pressure could be 7.0 Kg/cm². Reduction in set pressure by 0.8 Kg/cm² to 1.0 Kg/cm² will result in reduction in power consumption.

3. Proposition is to switch over to LED lights owing to the following advantages.

- Emphasis is given on use of LED lights owing to the following features and advantages.
- Present day LED fittings have come very close to CFL fittings for general illumination needs
- One to one basis retrofit of LED lights is possible with most conventional type CFL& FTL light fittings
- Life of LED fittings is 50, 000 burning hours as against about 5000 burning hours of CFL Lights.
- The life span of 10 times reduces efforts maintenance and labor of replacement as is the case with CFL and FTL lamps. For average use exceeding 10 hours the typical pay back for LED lights works out to 3.5 to 4 years. The rest of the life span of 6 to 6.5 years results total savings.
- As the savings with LED lights are realized with reduction in wattages for same light output, there is saving in demand as well.
- As the heat dissipation by LED light is negligible compared to CFL and FTL lights, it saves on air conditioning power also.

4. LED

- The life span of LED is much longer compared to CFL and FTL. In places where the daily use is say 10 hours (yearly use of 3650 hours), the LED would last for $50,000/3,650 = 13.69$ years. This is longer period to realization of payback.
- Under such circumstances buyers should ask for minimum 25,000 hours at site replacement warranty so the investment is safe.
- Each fitting may have date embossed / permanently marked for identification so that

replacement can be claimed without hassle.

- As LED lamps have high onetime cost such lamps may be installed with care in public areas or areas where possibility of theft is high.
- A specific area may first be chosen so that practical difficulties of implementation are understood and overcome. Also time is given for performance evaluation and energy saving is registered and documented.

5. Use of Electronic Savers for Air Conditioners

- These savers have electronic controls which give close over ride on the built in thermostat, thereby offering closer temperature control through modulation of compressor. Generally reputed brands can show 10 to 12% savings in the power consumption. These units could be installed with Window and Split AC units.
- The thermostat fitted in the air conditioner provides only a crude control of the temperature resulting in overshoot or undershoot of the set temperature, which results in wastage of energy. Further, when the thermostat fails, the A/C works continuously and it is difficult to recognize this failure and take corrective action. This results in wastage of energy

6. Replacement of existing / Old A.C. Units with BEE Star rated A. C. units

- Life of split or widow air conditioner is considered to be about 8 years. Due fouling and ageing the energy efficiency of these units comes down rapidly as they advance toward life exhaustion.
- Bureau of Energy Efficiency have assigned star rating for these air conditioners. The annual savings have been shown in the table below. Under well chalked out program if the old AC units whose life is more than 6 years are replaced with star 4 or star 5 AC units of equal capacity the savings are obvious.

7. Use of Alternate Fuel

- Briquette Firing in place of diesel - At present laundry boilers use diesel as fuel. Bio mass briquettes are proposed as alternate fuel in place of diesel. Comparative presentation on energy charge basis is as follows:

8. Combination of Solar & Briquette Firing

- Thermal solar can be used for preheating of feed water to the boiler. Major problem faced by most thermal solar systems is hardness of water which chokes up the pipes and corrodes the tubes and pipes.
- In this case special thermal solar has been taken into consideration that can withstand hard water and work without problems.

8.9 GENERALISED ENERGY CONSERVATION TIPS

Apart from the above-mentioned priorities, there are certain tips that management should examine in future to increase energy efficiency and hence to cut down on energy costs.

8.9.1 Electricity

- ✓ Optimize the tariff structure with utility supplier
- ✓ Schedule your operations to maintain a high load factor
- ✓ Minimize maximum demand by tripping loads through a demand controller
- ✓ Stagger start-up times for equipment with large starting currents to minimize load peaking.
- ✓ Use standby electric generation equipment for on-peak high load periods.
- ✓ Correct power factor to at least 0.95 under rated load conditions.
- ✓ Relocate transformers close to main loads.
- ✓ Set transformer taps to optimum settings.
- ✓ Disconnect primary power to transformers that do not serve any active loads
- ✓ Consider on-site electric generation or cogeneration.
- ✓ Export power to grid if you have any surplus in your captive generation.
- ✓ Check utility electric meter with your own meter.
- ✓ Shut off unnecessary computers, printers and copiers at night

8.9.2 Motors

- ✓ Properly size to the load for optimum efficiency.(High efficiency motors offer of 4 – 5% & higher efficiency than standard motors)
- ✓ Use energy-efficient motors where economical.
- ✓ Use synchronous motors to improve power factor.
- ✓ Check alignment.
- ✓ Provide proper ventilation (For every 10⁰C increase in motor operating temperature over recommended peak, the motor life is estimated to be halved)
- ✓ Check for under-voltage and over-voltage conditions.
- ✓ Imbalanced voltage reduces motor input power supply by 3 – 5%, so balance of 3 phase power supply is essential.
- ✓ The Demand efficiency reduces by 5-8% if rewinding is not done properly.

8.9.3 Drives

- ✓ Use variable-speed drives for large variable loads.
- ✓ Use high-efficiency gear sets.
- ✓ Use precision alignment.
- ✓ Check belt tension regularly.
- ✓ Eliminate variable-pitch pulleys.
- ✓ Use flat belts as alternatives to v-belts.
- ✓ Eliminate Eddy Current coupling; synthetic lubricants are useful for large gearboxes.
- ✓ When not needed, switch off them.

8.9.4 Fans

- ✓ Avoid poor flow distribution at the fan inlet by using smooth, well rounded air inlet cones for fan intakes.
- ✓ Clean Filters, Fan Blades & Screens on regular interval. Also minimize fan obstructions from inlet and outlet points.
- ✓ Acrofoil shaped fan blades, are useful and can consider.
- ✓ Use low slip, flat belts and minimize fan speed.
- ✓ Maintain belt tension, by regular checking.
- ✓ Eliminate pitch pulleys variables.
- ✓ For Large variable fan loads, use variable speed drives.
- ✓ Use energy efficient motors for continuous operation
- ✓ Eliminate leaks & Minimize bends in ductwork.
- ✓ When not needed, Turn fans off.

8.9.5 Compressors

- ✓ On positive displacement compressors for Variable loads, consider variable speed drives.
- ✓ Use a synthetic lubricant if permitted by OEM.
- ✓ Ensure lubricating oil temperatures, it should not be too high to avoid oil degradation and lowered viscosity. And should not be too low for condensation contamination.
- ✓ Regularly, clean and change the oil filters.
- ✓ For proper functioning conduct periodic checkup & inspection of compressor intercoolers.
- ✓ To power preheat process, use water heat from a very large compressor.
- ✓ Do an energy audit and follow-up the findings.
- ✓ Establish a efficiency & maintenance scheduled programs for compressors. Make it a part of your continuous energy management program.

8.9.6 Pumps

- ✓ Operate pumping near best efficiency point. Modify pumping to minimize throttling.
- ✓ Adapt to side load variation with variable speed drives or sequenced control of smaller units.
- ✓ Stop running both pumps – add an auto-start for an on-line spare or add a booster pump in the problem area.
- ✓ Use booster pumps for small load as requiring higher pressures. Increase fluid temperature differentials to reduce pumping rates. Repair seals and packing to minimize water waste.
- ✓ Balance the system to minimize flows and reduce pump power requirements.
- ✓ Use siphon effect to advantage: don't waste pumping head with a free-fall (gravity) return.

8.9.7 Blowers

- ✓ For air Intakes, use cone & ducts for smooth & rounded air inlet.
- ✓ Remove obstructions from blower inlet and outlet points.
- ✓ Regularly, clean screens & filters. Replaced essentially.
- ✓ Maintain Blower speed.
- ✓ Keep belt tension as required, use standard OEM suggested belts with low-slip or no-slip.
- ✓ Eliminate variable pitch pulleys.
- ✓ Use variable speed drives for large variable blower loads.
- ✓ Use energy-efficient motors for continuous operation.
- ✓ Turn blowers off when they are not needed.

8.9.8 Compressed Air

- ✓ Install a control system to co-ordinate multiple air compressors.
- ✓ For operating multiple air compressors with most efficient mode - Study part-load characteristic and cycling costs.
- ✓ Match the connected load -Avoid over sizing.
- ✓ Load up modulation-controlled air compressors. (They use almost as much power at partial load as at full load.)
- ✓ Turn off the back-up air compressor until it is needed.
- ✓ Reduce air compressor discharge pressure to the lowest acceptable setting. (*Reduction of 1 kg/cm² air pressure (8 kg/cm² to 7 kg/cm²) would result in 9% input power savings. This will also reduce compressed air leakage rates by 10%*)
- ✓ Use the highest reasonable dryer dew point settings.
- ✓ Turn off refrigerated and heated air dryers when the air compressors are off. Use a control system to minimize heatless desiccant dryer purging.
- ✓ Minimize purges, leaks, excessive pressure drops and condensation accumulation. (*Compressed air leak from 1 mm hole size at 7 kg/cm² pressure would mean power loss equivalent to 0.5 KW*)
- ✓ Use drain controls instead of continuous air bleeds through the drains.
- ✓ Consider engine-driven or steam-driven air compression to reduce electrical demand charges.
- ✓ Replace standard V-belts with high-efficiency flat belts as the old V-belts wear out. Use a small air compressor when major production load is off.
- ✓ Take air compressor intake air from the coolest (but not air conditioned) location. (*Every 5°C reduction in intake air temperature would result in 1% reduction in compressor power consumption*)
- ✓ Use an air-cooled after cooler to heat building makeup air in winter, ensure foul for heat exchangers.
- ✓ Be sure that air / oil separators are not fouled.
- ✓ Clean regularly filters and replace it promptly upon alarm. Regularly, monitor pressure drops across suction and discharge of filters.
- ✓ Use properly sized compressed air storage receiver.
- ✓ Minimize disposal costs by using lubricant that is fully demulsible.
- ✓ Find out alternatives to compressed air and use same where ever possible. Example; Blowers for cooling, Hydraulic in place of air cylinders, electric in place of air actuators & pneumatic controls.
- ✓ Use nozzles or venturi - type devices instead of blowing with open compressed air lines.
- ✓ Check for leaking drain valves on compressed air filter / regular sets. Certain rubber-type valves may leak continuously after they age and crack.
- ✓ Industry environments, control packaging lines with high-intensity photocell units instead of standard units with continuous air purging of lenses and reflectors.
- ✓ Do an energy audit and follow-up the findings.
- ✓ Establish a efficiency & maintenance scheduled programs for compress Air. Make it a part of your continuous energy management program.

8.9.9 Chillers

- ✓ Set point check and maintain for chilled water temperature.
- ✓ Use the low temp. Condenser water available that the chiller can handle.
- ✓ Increase the evaporator temperature.
- ✓ When fouled, clean heat exchangers.
- ✓ Replace whenever essential old chillers/compressors with new higher-efficiency models.
- ✓ Use water-cooled in place air-cooled chiller condensers.
- ✓ Use energy-efficient motors for continuous operation.
- ✓ Specify for condenser – ‘Fouling factors’ clean or replace filters promptly upon alarm.
- ✓ Overcharging of oil is not correct.
- ✓ To co ordinate multiple chillers, install a control system.
- ✓ To determine most efficient mode for operating multiple chillers, perform the study part for knowing load characteristics & cost of cycle.
- ✓ Run the chillers to near base load for the lowest operating costs. Over sizing to match the connected load must be avoided.
- ✓ Off line chillers & cooling towers must be isolated.
- ✓ Do an energy audit and follow-up the findings.
- ✓ Establish a efficiency & maintenance scheduled programs for chillers. Make it a part of your continuous energy management program.

8.9.10 Refrigeration

- ✓ Use water-cooled condensers rather than air-cooled condensers. Challenge the need for refrigeration, particularly for old batch processes. Avoid over sizing – match the connected load.
- ✓ Consider gas-powered refrigeration equipment minimize electrical demand charges.
- ✓ Use “free cooling” to allow chiller shutdown in cold weather. Use refrigerated water loads in series if possible.
- ✓ Convert firewater or other tanks to thermal storage.
- ✓ Don’t assume that the old way is still the best – particularly for energy-intensive low temperature systems.
- ✓ Correct inappropriate brine or glycol concentration that adversely affects heat transfer and / or pumping energy. If it sweats, insulate it, but if it is corroding, replace it first.
- ✓ Make adjustments to minimize hot gas bypass operation. Inspect moisture / liquid indicators.
- ✓ Consider change of refrigerant type if it will improve efficiency. Check for correct refrigerant charge level.
- ✓ Inspect the purge for air and water leaks.
- ✓ Do an energy audit and follow-up the findings.
- ✓ Establish a efficiency & maintenance scheduled programs for refrigeration. Make it a part of your continuous energy management program.

8.9.11 HVAC

- ✓ Tune up the HVAC control system.
- ✓ Consider installing a building automation system (BAS) or energy management system (EMS) or restoring an out-of-service one.

- ✓ Balance the system to minimize flows and reduce blower / fan / pump power requirements.
- ✓ Eliminate or reduce reheat whenever possible.
- ✓ Use appropriate HVAC thermostat setback.
- ✓ Use morning pre-cooling in summer and pre-heating in winter (i.e. – before electrical peak hours).
- ✓ Use building thermal lag to minimize HVAC equipment operating time.
- ✓ In winter during unoccupied periods, allow temperature to fall as low as possible without damaging stored materials.
- ✓ Improve control and utilization of outside air.
- ✓ Use air-to-air heat exchangers to reduce energy requirements for heating and cooling of outside air.
- ✓ Reduce HVAC system operating hours (e.g. – night, weekend). Optimize ventilation.
- ✓ Ventilate only when necessary. To allow some areas to be shut down when unoccupied, install dedicated HVAC systems on continuous loads (e.g. – computer rooms).
- ✓ Provide dedicated outside air supply to cleaning rooms, combustion equipment, etc. to avoid excessive exhausting of conditioned air.
- ✓ In dry climates, use evaporative cooling.
- ✓ During unoccupied periods, reduce humidification or dehumidification. Use atomization in place of steam for humidification. Clean HVAC unit coils periodically & Comb mashed fins.
- ✓ To reduce pressure drop, upgrade filter banks it lower fan power requirements. Monthly check HVAC filters and clean, change if appropriate.
- ✓ For proper operation cycle and maintenance check pneumatic controls air compressors.
- ✓ Use high-speed doors or clear PVC strip curtains to isolate air conditioned loading dock areas and cool storage areas.
- ✓ In high bay areas, install ceiling fans to minimize thermal stratification.
- ✓ In areas with high ceilings, relocate air diffusers to required heights. Possible, then reduce ceiling heights.
- ✓ Eliminate obstructions in front of radiators, baseboard heaters, etc.
- ✓ For dust and vapor control, use professionally designed ventilation hoods.
- ✓ Use spot cooling and heating
- ✓ Purchase only high-efficiency models for HVAC window units. Use time controller, for HVAC window units.
- ✓ Short cycle is the result of oversized units in poor humidity control, so don't oversize cooling unit.
- ✓ Install multi-fuelling capability and run with the cheapest fuel available at the time. Consider dedicated make-up air for exhaust hoods.
- ✓ Minimize HVAC fan speeds.
- ✓ In humid climates, consider desiccant drying of air to reduce cooling requirements.
- ✓ Seal leaky HVAC ductwork & around coils.
- ✓ Repair loose or damaged flexible connections including those under air handling units.
- ✓ Eliminate simultaneous heating and cooling during seasonal transition periods.
- ✓ Zone HVAC air and water systems to minimize energy use.
- ✓ Keep regular check on damper blades and linkages.
- ✓ Do an energy audit and follow-up the findings.
- ✓ Establish a efficiency & maintenance scheduled programs for HVAC system. Make it a part of your continuous energy management program.

8.9.12 Cooling Towers

- ✓ Control cooling tower fans based on leaving water temperatures.
- ✓ Control to the optimum water temp. as determined from CT and chiller performance.
- ✓ Use two-speed or variable-speed drives for cooling tower fan control if the fans are few. Stage the cooling tower fans with on-off control if there are many.
- ✓ Turn off unnecessary cooling tower fans when loads are reduced.
- ✓ Cover hot water basins (to minimize algae growth that contributes to fouling). Balance flow to cooling tower hot water basins.
- ✓ Periodically clean plugged cooling tower water distribution nozzles. Install new nozzles to obtain a more-uniform water pattern.
- ✓ Replace splash bars with self-extinguishing PVC cellular-film fill.
- ✓ An old counter flow cooling towers, replace old spray-type nozzles with new square-spray ABS practically-non-clogging nozzles.
- ✓ Replace slat-type drift eliminators with high-efficiency, low-pressure-drop, self-extinguishing, and PVC cellular units.
- ✓ If possible, follow manufacturer's recommended clearances around cooling towers and relocate or modify structures, signs, fences, etc. that interfere with air intake or exhaust.
- ✓ Optimize cooling tower fan blade angle on a seasonal and / or load basis.
- ✓ Correct excessive and / or uneven fan blade tip clearance and poor fan balance. Use a velocity pressure recovery fan ring.
- ✓ Divert clean air-conditioned building exhaust to the cooling tower during hot weather. Re-line leaking cooling tower cold water basins.
- ✓ Check water overflow pipes for proper operating level. Optimize chemical use.
- ✓ Consider side stream water treatment.
- ✓ Restrict flows through large loads to design values. Shut off loads that are not in service.
- ✓ Take blow down water from the return water header. Optimize blow down water from the return water header. Automate blow down to minimize it.
- ✓ Send blow down to other uses (Remember, the blow down does not have to be removed at the cooling tower. It can be removed anywhere in the piping system.) Implement a cooling tower winterization plan to minimize ice build-up.
- ✓ Install interlocks to prevent fan operation when there is no water flow.
- ✓ Do an energy audit and follow-up the findings.
- ✓ Establish a efficiency & maintenance scheduled programs for Cooling tower. Make it a part of your continuous energy management program.

8.9.13 Lightings

- ✓ Reduce excessive illumination levels to standard levels using switching, delamping, etc. (Know the electrical effects before doing delamping.)
- ✓ Aggressively control lighting with clock timers, delay timers, photocells, and / or occupancy sensors.
- ✓ Install efficient alternatives to incandescent lighting, mercury vapour lighting, etc. as follows: low pressure sodium, high pressure sodium, metal halide, fluorescent, mercury vapor, incandescent.
- ✓ Select ballasts and lamps carefully with high power factor and long-term efficiency in mind.
- ✓ Upgrade obsolete fluorescent systems to compact fluorescents and electronic ballasts. Consider lowering the fixtures to enable using less of them.
- ✓ Consider day lighting, skylights, etc for its utilization.
- ✓ Consider painting the walls a lighter color.
- ✓ Using less lighting fixtures or lower wattages.
- ✓ Use task lighting and reduce background illumination.
- ✓ Evaluate exterior lighting strategy w. r. t. its type, use & control.
- ✓ Change exit signs from incandescent to LED, wherever possible.

8.9.14 D G Sets

- ✓ Optimize loading.
- ✓ Use waste heat to generate steam, hot water or preheat processes.
- ✓ Use jacket and head cooling water for process needs.
- ✓ Clean air filters regularly.
- ✓ Insulate exhaust pipes to reduce DG set room temperatures.

8.9.15 Buildings

- ✓ Install windbreaks near exterior doors.
- ✓ Replace single-pane glass with insulating glass.
- ✓ If visibility is not required but light is required, consider replacing exterior windows with insulated glass block.
- ✓ Consider tinted glass, reflective glass, coatings, awnings, overhangs, draperies, blinds and shades for sunlit exterior windows.
- ✓ Use landscaping to advantage.
- ✓ Consider automatic doors, air curtains, strip doors, etc. at high-traffic passages between conditioned and non-conditioned spaces. Use self-closing doors if possible.
- ✓ Use intermediate doors in stairways and vertical passages to minimize building stack effect.
- ✓ Use dock seals at shipping and receiving doors.
- ✓ Bring cleaning personnel in during the working day or as soon after as possible to minimize lighting and HVAC costs.

8.9.16 Waste & Waste water

- ✓ Recycle water, particularly for uses with less-critical quality requirements.
- ✓ Recycle water, especially if sewer costs are based on water consumption.
- ✓ Balance closed systems to minimize flows and reduce pump power requirements. Eliminate once-through cooling with water.
- ✓ Use the least expensive type of water that will satisfy the requirement.
- ✓ Fix up water leaks.
- ✓ Test for underground water leaks. (It's easy to do over a holiday shutdown.)
- ✓ Check water overflow pipes for proper operating level.
- ✓ Provide proper tools for wash down – especially self-closing nozzles.
- ✓ Install efficient irrigation.
- ✓ Reduce flows at water sampling stations.
- ✓ Eliminate continuous overflow at water tanks.
- ✓ Promptly repair leaking toilets and faucets.
- ✓ Use water restrictors on faucets, showers, etc. Use self-closing type faucets in restrooms.
- ✓ Use the lowest possible hot water temperature.
- ✓ Do not use a heating system hot water boiler to provide service hot water during the cooling season – install a smaller, more-efficient system for the cooling season service hot water.
- ✓ If water must be heated electrically, consider accumulation in a large insulated storage tank to minimize heating at on-peak electric rates.
- ✓ Use multiple, distributed, small water heaters to minimize thermal losses in large piping systems.
- ✓ Consider leased and mobile water treatment systems, especially for deionised water.
- ✓ Seal sumps to prevent seepage inward from necessitating extra sump pump operation.
- ✓ Install pre-treatment to reduce TOC and BOD surcharges.
- ✓ Verify the water meter readings.
- ✓ STP: Considering the present scenario of sewage water collection area within campus and the treatment plant few kilometers away from campus, the installation needs improvement. The existing pumps and overall installation is doubted to under capacity by considering the future expansion.

8.9.17 Miscellaneous

- ✓ Meter any unmetered utilities. Know what normal efficient use is. Track down causes of deviations.
- ✓ Shut down spare, idling or unneeded equipment.
- ✓ Make sure that all of the utilities to redundant areas are turned off – including utilities like compressed air and cooling water.
- ✓ Install automatic control to efficiently co-ordinate multiple air compressors, chillers, cooling tower cells, boilers, etc.
- ✓ Renegotiate utilities contracts to reflect current loads and variations.
- ✓ Consider buying utilities from neighbors, particularly to handle peaks.
- ✓ Leased space often has low-bid inefficient equipment.
- ✓ Consider upgrades if your lease will continue for several more years.
- ✓ Adjust fluid temperature within acceptable limits to minimize undesirable heat transfer in long pipelines.
- ✓ Minimize use of flow bypasses and minimize bypass flow rates. Provide restriction orifices in purges (nitrogen, steam, etc.).
- ✓ Eliminate unnecessary flow measurement orifices.
- ✓ Consider alternatives to high pressure drops across valves.
- ✓ Turn off winter heat tracing that is on in summer.

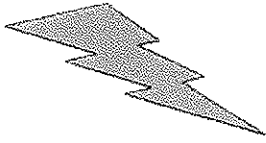

ENERGY AUDIT REPORT

September 2019

Prepared For ,
Krishna Institute of Medical Sciences
'Deemed to be University'

Malakapur, Pune-Bangalore Highway, Tal.: Karad, Dist.:
Satara Pin Code : 415 539, State : Maharashtra, India

Prepared By,

Green Scientific Development (I) Pvt. Ltd.

4/ 'A' Wing, Bldg. No. 23, Tulsi C.H.S. Ltd., Subhash Nagar,
Chembur, Mumbai, Pin Code: 400 071, Maharashtra, India
greenscientificdevelopment@gmail.com

REGISTRAR
Krishna Institute of Medical Sciences
"Deemed To Be University", Karad

TABLE OF CONTENTS

1	CERTIFICATE	01
2	PREFACE	03
3	ACKNOWLEDGEMENT	04
4	ABBREVIATIONS.....	05
5	EXECUTIVE SUMMARY	06
6	BASIC DETAILS.....	08
7	INTRODUCTION.....	09
7.1	Preamble.....	09
7.2	Objectives.....	09
7.3	Scope of Work.....	09
7.4	Methodology.....	11
8	ENERGY PERFORMANCE ASSESSMENT AND SAVINGS OPPORTUNITIES.....	13
8.1	Electricity Consumption	13
8.1.1	Electricity Consumption from Grid	13
8.1.2	Electricity Generation using Solar PV system.....	14
8.1.3	Electricity Generation using DG sets	15
8.2	Regression Analysis	15
8.3	Air Compressor.....	17
8.4	Lighting System (Indoor & Outdoor).....	20
8.5	Hot Water Generation.....	21
8.6	Air Conditioning System	24
8.7	Implementation Methodology.....	27
8.8	Additional Energy Savings Recommendations	27
8.8.1	Electricity.....	27
8.8.2	Motors	28
8.8.3	Drives	28
8.8.4	Fans	28

8.8.5	Blowers	29
8.8.6	Pumps.....	29
8.8.7	Air Compressors.....	30
8.8.8	Compressed Air System	30
8.8.9	Chillers	31
8.8.10	Heating, Ventilation and Air Conditioning.....	32
8.8.11	Refrigeration.....	34
8.8.12	Cooling Towers	34
8.8.13	Lighting.....	36
8.8.14	Solar PV Plant.....	36
8.8.15	DG Sets.....	37
8.8.16	Buildings.....	37
8.8.17	Waste & Waste Water	38
8.8.18	Miscellaneous.....	39

List of Tables

Table 1. Electricity Consumption (2015-18)	13
Table 2. Solar PV Generation	14
Table 3. Diesel Consumption – 2015-2018	15
Table 4. Cooling Degree Days – 2018	16
Table 5. Air Compressor & Vacuum Details	17
Table 6. Air Dryer Details	18
Table 7. Arrestation of compressed air leakages in the system.....	18
Table 8. Cut-off pressure reduction instead of Pressure Reducing Valve.....	20
Table 9. Replacement of existing lighting system with LEDs.....	21
Table 10. Hot water requirements.....	21
Table 11. Solar Evacuated Tube Water Heater.....	22
Table 12. Heat Pump for Hot Water Generation	23
Table 13. Replacement of Split/Window ACs with VRV system	24
Table 14. Replacement of Split/Window ACs with 5-star inverter split ACs	25
Table 15. Energy Savings – Solar Thermal Hybrid VRF System.....	26

List of Figures

Figure 1. Electricity Consumption Comparison (2015-18)	14
Figure 2. Regression – Electricity vs. CDD	16
Figure 3. Ultrasonic Compressed Air Leakage Detection.....	19
Figure 4. Artificial Demand of Air Compressor	19
Figure 5. Solar Evacuated Water Heater	22
Figure 6. Heat Pump.....	23
Figure 7. Schematic of Solar Thermal VRF Hybrid System.....	25

1 CERTIFICATE

This Energy Audit Report is prepared & documented for Krishna Institute of Medical Sciences 'Deemed to be University', (KIMSDU) Karad, Maharashtra State on a best judgment basis by "Green Scientific Development (I) Pvt. Ltd (GSDIPL), Mumbai. The details contained in this report have been compiled in good faith based on the basis of information provided & shared by KIMSDU, Karad.

We further submit that the projections are the management's best estimates and no representation, warranty or undertaking, express or implied is made and no responsibility is accepted by Green Scientific Development (I) Pvt. Ltd and / or its affiliates and / or its Directors, employees / officers in this report or for any direct or consequential loss arising from any use of the information, statements or forecasts in the report.

Energy Auditor
(Certificate No. EA 4593)
Mr. Shripad Vishnu kale



(C.S.V. Kale)

Energy Manager
(Certificate No. 6827)
Mr. Bhalchandra Shridhar Bhurke



Director, GSDIPL
EMS ISO 14001 Lead Auditor
Mr. Kiran Mahadev Shinde

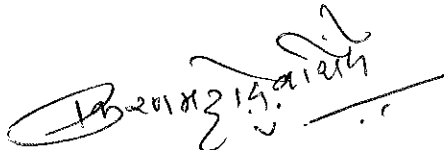



Serial No. 1765

CERTIFIED ENERGY AUDITOR CUM ENERGY MANAGER



Name: Shripad Vishnu Kale
 Father's Name: Vishnu Krishna Kale
 Reg. No: EA-4593

Year of Passing: Apr-06
 Date of Issue: 15.05.2018

Signature of the Holder: _____
 Issuing Authority Secretary (BEE)

TUV NORD

PR315: ISO 14001:2015 Lead Auditor (Environmental Management Systems) Training course

Certificate of Achievement

Mr Kiran M Shinde

has successfully completed the above mentioned course and examination
 11th - 15th March 2019
 MUMBAI INDIA

Signature: _____
 Date: 15.03.2019

Logo of COI and IRCA

Regn. No.EM-6924

Certificate No.6827



National Productivity Council
 (National Certifying Agency)

PROVINCIAL CERTIFICATE

This is to certify that Mr./Mrs./Ms. Bhalchandra Shridhar Bhurke
 son / daughter of Mr. Shridhar
 has passed the National Certification Examination for Energy Managers held in September-2015 conducted on behalf of the Bureau of Energy Efficiency, Ministry of Power, Government of India and is qualified as Certified Energy Manager.
 This certificate is valid till the issuance of an official certificate by the Bureau of Energy Efficiency.

Place : Chennai, India
 Date : 10th February 2016

Signature: _____
 Controller of Examination

2 PREFACE

In the State Maharashtra and district Satara, KIMSDU is an important centre of medical education hub who offers undergraduate degree and diplomas for post-graduation in various branches of medical sciences. Krishna hospital is committed to provide standard treatments and quality care. Management is well aware and taking at most care & Responsibility for sustainable development of institutional all the activities.

With spiralling energy costs, KIMSDU appointed Green Scientific Development (I) Pvt Ltd with interest to trim down energy consumption and cost. The energy audit assignment is conducted for checking levels of energy aspects at the KIMSDU Facility, Karad.

The energy audit is aimed at recording and quantification of the energy consumption at location. Subsequently, it also tries to explore the possibilities of conserving energy through better practices and employment of latest technologies.

The report has classified the suggestions in to short, medium and long-term investment opportunities so that the management can take up the implementation according to investment and payback priorities.

3 ACKNOWLEDGEMENT

This Energy Audit is conducted hand in hand with the institutional staff assigned & involved in energy aspect by keeping common goal of accounting & contain energy usage without sacrificing the purpose of use of energy at its optimum requirement.

The institutional team had put there all possible interest, involvement & participated equally without which it would not be achieved satisfactorily.

We are thankful to the Top Management of Institute for appointing us to conduct energy audit. We further thanks for the contribution of the following dignitaries because of whom the study could progress smoothly to achieve its aim and objective;

- Mr. (Dr.) M. V. Ghorpade Registrar
- Mr. Sataynaryan Mashalkar Asstt. Registrar
- Mr. Tushar Kadam Administrative Officer
- Mr. Yogesh Kulkarni HOD Electrical

Last but not least, thanks to all those who contributed and putting continuous efforts for the success of energy saving, continual improvement & sustainable development during performance of all the institutional activities.

4 ABBREVIATIONS

Abbreviations	Full Form
Asstt.	Assistant
A	Ampere
AC	Alternating Current
AC's	Air Conditioner
Avg.	Average
°C	Degree Centigrade
COP	Co-Efficient Of Performance
DC	Direct Current
Eff.	Efficiency
GSDIPL	Green Scientific Development (I) Pvt. Ltd.
HVAC	Heating Ventilation and Air Conditioning
HP	Horse Power
KIMSDU	Krishna Institute of Medical Sciences 'Deemed to be university'
KV	Kilo Volt
KvA	Kilo Volt Ampere
kW	Kilo Watts
Kwp	Kilo Watts Power
LPD	Liters Per Day
M or m	Meter
m/c	Machine
Min.	Minimum
mm	Millimeter
MSEDCL	Maharashtra State Electricity Distribution Company Ltd.
PRV	Pressure Reducing Valve
RH	Relative Humidity
Sec.	Second
SPV	Solar Photovoltaic
SWH	Solar Water Heater
THD	Total Harmonic Dispersion
V	Voltage
VFD	Variable Frequency Drive
VRV	variable refrigerant valve

5 EXECUTIVE SUMMARY

The major potential savings along with investment and payback period are given below.

Sr. No.	Energy Conservation Measures	Annual Savings		Investment (Rs. Lakhs)	Simple Payback Period (Months)
		Electricity (kWh)	Rs. Lakhs		
1	Arrestation of compressed air leakages in the system	6479	0.93	NIL	Instant
2	Cut-off pressure reduction instead of Pressure Reducing Valve	1204	0.17	NIL	Instant
3	Replacement of existing lighting system with LEDs (Considering around 50% of total replacement)	56340	8.12	30	12
4	Use of solar water heater for hot water generation	111714	16.1	10	12
5	Use of Heat Pump for Hot Water Generation	72242	10.41	25	29
6	Replacement of window / split AC with 5 star inverter type air conditioners	241210	34.78	70	25
7	Installation of solar hybrid VRF system for air conditioning	42647	6.15	15	29

Review of energy conservation activities done at site are summarised below:-

Approximately Saving in 2018-2019

Sr. No	Description	Saving / kWh
1	39 Watt LED Light, Qty - 21 From Sept 2015, Saving	13097
2	Solar System 10 Kwp from Oct 2015, Saving	13096
3	Energy Efficient 750 Kva trans, Install, May 2016 Saving	21900
4	Installation of APFC Panel, May 2016, Saving	276000
5	Hybrid solar System 35Out put Kw- Input 10Kw , Saving from Sept 2016	39087
6	International Hostel Led Lights, Total 7 Kw , 0.4 D. F x 6 Hours, May 2017 saving 80%	4435
7	VRV System 148 HP, May 2017, Saving 20% against regular AC [[Kw 110 x Df 0.4 x 300) x 20%]	13248
8	Inverter Ac installation Tr- saving 10% of regular AC 61 +17 AC (Year 105600unit consumption - saving 10%)	10560
9	Solar System 500 Kwp	720000

6 BASIC DETAILS

Name of institution	Krishna Institute of Medical Sciences 'Deemed to be University'
Location	Malakapur, Pune - Bangalore Highway, Karad - 415 539, Maharashtra, India
Year of Establishment	1984
Activity	Medical Education
Facility	Medical College, Hospitals
Energy Scene	
Major Connected load	Air/Vacuum Compressors, Geyser, Ovens, AC Units, Lighting, Pumps, Computers, Medical & Other Office Equipment, etc.
Major Energy Sources	Electricity from the Grid
Energy Audit Date	09 September 2019

7 INTRODUCTION

7.1 Preamble

- Krishna Institute of Medical Sciences 'Deemed to be University' has a facility at Karad.
- The Campus is serviced by utilities like window & split AC's, lighting, electrical geysers, boilers, medical & office equipment like CT scan m/c's, MRI m/c's etc. as support services.
- With increasing energy costs, management approached GSDIPL for the energy audit of KIMSDU.
- GSDIPL submitted its proposal. This proposal was accepted by KIMSDU.
- This energy audit report for KIMSDU, Karad campus presents
 - The analysis of the data collected,
 - Field trials undertaken.
 - Observations, Recommendations & General Tips
- This energy audit report for is governed by the objectives, scope of work, and methodology discussed in ensuing paragraphs.

7.2 Objectives

- To undertake an energy audit so as to identify areas for energy saving
- To prioritize distinct areas identified for energy savings depending upon
 - Saving potential,
 - Skills,
 - Time frame for execution,
 - Investment cost,
 - Payback

7.3 Scope of Work

- To correlate monthly data of activity with energy consumption for annum.
- To study electrical energy metering, monitoring and control system existing at the institute and to recommend a suitable system for future monitoring.
- To study monthly power factor, maximum demand, working hours, load factor etc.

- Detailed Load management study for the reference period along with monthly electricity consumption and establish scope for Max Demand control through possible optimization of load factor.
- To undertake a detailed motor load study on major continuously operating motors equal to and above 10 HP with the help of a clamp on multi-meter to identify instantaneous motor parameters like kW, kVA, P.F., A, V, frequency etc.
- Based on above, to evaluate the possibility of replacing major motors with energy efficient motors.
- To study compressed air & nitrogen distribution system in the plant, in terms of compressor type, make, capacity, loading, motor type / size / loading etc. and to undertake output efficiency test for the operating compressors.
- To study existing requirements of chilled water/conditioned air provisions at present locations and to identify distinct possibilities of rationalization /savings.
- To study operation of chilled water/conditioned air with the help of operating records kept and spot measurements taken during the field study and identify COP for chilling compressors in usage and identify scope for optimization through improved operating/maintenance practices.
- To study existing maintenance practices for chilled water / air conditioning system and recommend areas for improvement in energy efficiency /savings.
- To identify, evaluate and prioritize energy saving opportunities into short, mid and long- term time spans depending upon investments, quantum of savings, skills and time required for implementation, etc.
- To recommend a time-bound action plan for implementation of accepted measures.
- To prepare draft energy audit report, present to management, undertake necessary modifications based on presentation meeting and submit the final report.

7.4 Methodology

Audit Team:

GSDIPL deputed team of experts for conducting the study and worked in close association with KIMSDU unit personnel.

Energy Auditor : Mr. Shripad Kale - BEE Certified Energy Auditor

Energy manager : Mr. Bhurke Bhalchandra - BEE Certified Energy Manger, ISO 45000LA

Client Rep. : Mr. Yogesh Kulkarni - HOD Electrical

Documentation :

- GSDIPL submitted an execution work plan along with checklist to the KIMSDU.
- KIMSDU provided relevant data support.
- KIMSDU nominated responsible person involved in energy aspect from Engg./Maintenance sections along with subordinator & senior managerial level for achieving aim and goal.

Field / Site Visit :

- Opening Meeting - GSDIPL undertook an "Orientation Meeting" with team.
- GSDIPL's team conducted all necessary field trials admeasurements.
- GSDIPL provided all the instruments (List No 1) necessary for conducting the Field trials.
- Closing Meeting – On table Discussion conducted about field trial and its findings.

Report :

- Drafting of Report and its verification by management representative
- Final report submission to the management

List 1: List of the Instruments Used for Measurement

Instrument Name	Specification
Demand Analyzer	Suitable for electrical parameters like voltage, current, frequency, harmonics, active & reactive power, power factor etc.
Clamp-on Power Meter	0 - 1200 kW 0 - 600 Voltage, AC 0 - 800 Voltage, DC 0 - 2000 A, Current, AC / DC
Power Quality Analyzer	3 Ph. 4 Wire Recording Parameters: Voltage, Current, Frequency, Harmonics/ Inter harmonics up to 50 th , THD of V, I and KW with K Factor, Transients Voltage, All Power Parameters, Inrush current, Flicker Recording, Graphical, Vectorial, Numeric representation, trending of data, monitoring of events, etc.
Lux Meter	0 - 50,000 lux level (Non-Contact Type)
Digital Thermal Anemometer	0 - 45 m/sec. 3%
Relative Humidity and Temperature Indicator	RH – 10% to 95% Temp. – 0 to 100 °C
Infrared Thermometers	40 °C to 500 °C
Portable Temperature Indicator	50 °C to 1200 °C
Stop Watch	Standard

8 ENERGY PERFORMANCE ASSESSMENT AND SAVINGS OPPORTUNITIES

8.1 Electricity Consumption

8.1.1 Electricity Consumption from Grid

A study was conducted to observe the variations in the electricity consumption for the past 4 years. The details of the same are given below.

Table 1. Electricity Consumption (2015-18)

Sr. No	Month	2015	2016	2017	2018
1	Jan	2,45,929	2,55,796	2,63,948	2,88,465
2	Feb	2,45,422	2,75,923	2,66,003	2,77,245
3	Mar	3,22,926	3,37,871	3,35,145	3,85,470
4	Apr	3,41,002	3,44,734	3,75,878	3,79,342
5	May	3,55,948	3,94,154	3,76,928	3,93,323
6	Jun	3,27,814	2,93,753	3,53,685	3,32,145
7	Jul	3,11,106	2,83,980	3,23,798	3,14,145
8	Aug	3,15,782	3,01,410	3,32,145	3,07,747
9	Sep	3,10,796	2,87,348	3,37,290	3,12,053
10	Oct	3,39,025	2,92,808	3,25,125	3,21,097
11	Nov	2,82,100	2,68,298	3,13,583	2,57,715
12	Dec	2,82,363	2,58,923	2,84,858	2,57,100
Total		36,80,213	35,94,998	38,88,386	38,25,847

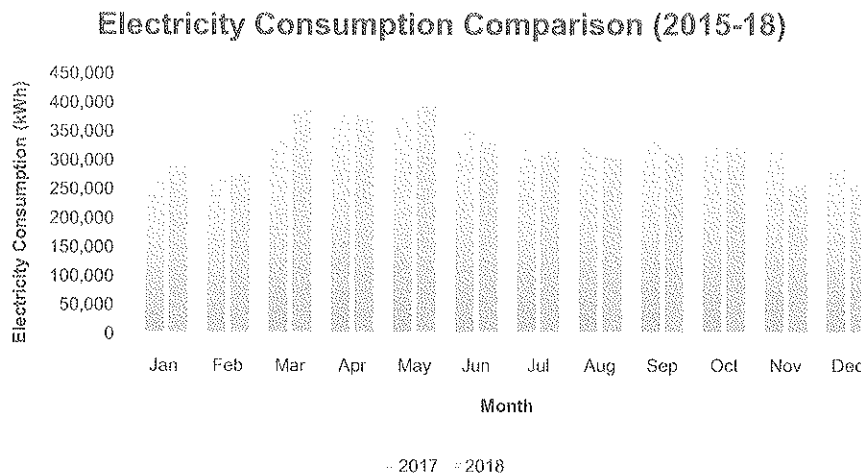

Figure 1. Electricity Consumption Comparison (2015-18)

From the above data, it can be seen that the minimum electricity consumption was in the year 2016 and maximum consumption was in the year 2017. Also, the annual electricity consumption did not change much in the year 2018 as compared to 2017. However, there is a variation in electricity consumption month-wise when compared between 2017 and 2018.

8.1.2 Electricity Generation using Solar PV system

Solar PV system of 500 kWp capacity was installed in the premise as a part of reduction in carbon emissions due to use of electricity. The details of the electricity generation month-wise from Solar Plant is given below.

Table 2. Solar PV Generation

Month	Solar PV Generation (kWh)
Apr-18	73,524
May-18	72,410
Jun-18	40,018
Jul-18	38,210
Aug-18	44,552
Sep-18	60,646
Oct-18	64,084
Nov-18	63,450
Dec-18	58,186
Total	515,080

Capacity Utilization Factor (CUF) of a Solar Plant is given by the ratio of actual amount of electricity generated to the maximum amount of electricity that can be generated.

CUF of the present system is 15.61%. As per MNRE report, the average CUF factor of a solar PV plant in India is between 15-19%.

8.1.3 Electricity Generation using DG sets

During power outage, as solar PV is also not available, DG sets were used as a backup option. The diesel consumption month-wise for the year of 2015 to 2018 is given below.

Table 3. Diesel Consumption – 2015-2018

Month	2015	2016	2017	2018
Jan	600	1600	1100	300
Feb	400	2200	700	700
Mar	600	1088	1400	600
Apr	800	3900	0	400
May	400	4200	3838	1500
Jun	800	800	7200	2300
Jul	300	700	1800	1300
Aug	1000	900	800	800
Sep	1400	1600	1300	1100
Oct	800	1200	1250	1500
Nov	400	1800	1300	1000
Dec	1200	1800	1400	800
Total	8700	21788	22088	12300

8.2 Regression Analysis

Heating and Cooling degree days (HDD/CDD) are used to indicate the effect of outside air temperature on building energy consumption during a specified time. They represent the number of degrees and the number of days that the outside air temperature at a specific location is lower/higher than a specified base temperature. Since the buildings are air-conditioned and no heating is involved, only CDD have been considered as independent variables.

The relationship between electricity consumption and cooling degree days is represented by the equation $y = mx + c$, alphabet 'y' represents energy consumption plotted on the y-axis and 'x' represents cooling degree days plotted on the x-axis. The slope of the line 'm' represents degree by which energy consumption varies corresponding to a rise of 'x' degree

days. Constant 'C is known as base load, which is considered to occur as a constant load and is independent of the number of degree days or sales or footfall. R² is the coefficient of determination of the model & if its value is above 0.75, then the model is considered to correlate considerably with the independent variable.

Table 4. Cooling Degree Days – 2018

Month	Cooling Degree Days
January	31.8
Feb	56.7
Mar	118.8
Apr	179.9
May	207.5
Jun	83.5
Jul	19.3
Aug	13.8
Sep	47.9
Oct	86.9
Nov	63.0
Dec	28.4

Monthly data for cooling degree days (CDD @ 24°C) and electricity consumption for the year January 2018 – December 2018 is shown in Table above. The CDD with a base value of 24°C is selected because the majority of the cooling load is for human comfort condition

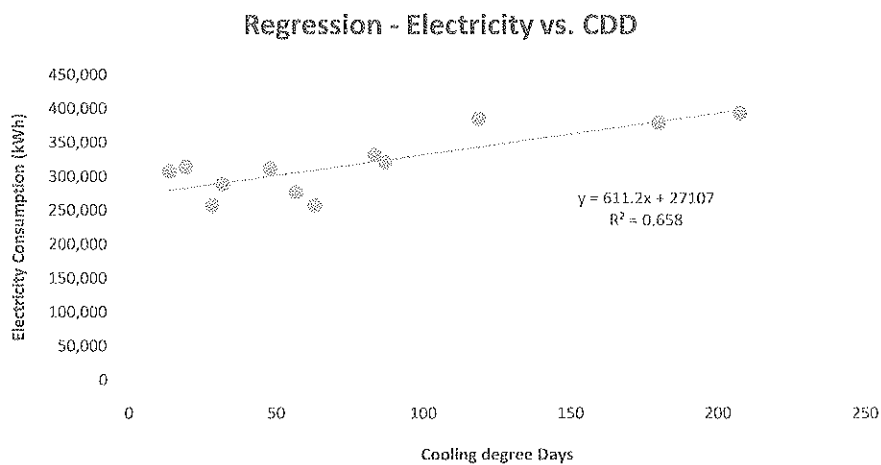

Figure 2. Regression – Electricity vs. CDD

The R^2 (coefficient of determination) value for the regression model is approximately 65.82%, this signifies that the weather (CDD) does not show any strong correlation with the electricity consumption of the facility.

It can be seen from the above figure that the electrical consumption does not comprise only of HVAC systems. However, it has been observed that the major connected load is HVAC systems comprising of approximately 1272 kW. So, there is a possibility of inefficiency in the HVAC systems which are indicated by the lower value of R^2 .

8.3 Air/Vacuum Compressor

Air/Vacuum Compressor is one of the energy intensive equipment in the whole premise. It is known that only about 10% of the input energy to the compressor is converted to useful compressed air energy. Performance of the air/vacuum compressor is of great importance and a significant amount of energy savings can be achieved from it. In determination of air compressor performance, Free Air Delivery of the compressor is carried out. Presently, there are 2 air compressors present in KIMSDU Dental College & Clinic. During the weekdays, the larger capacity compressor is used for approximately 10 hours. The lower capacity compressor is used only on Saturday. Following is the data of the existing air compressors and air dryer in the college and clinic.

Table 5 (a). Air Compressor Details

Sr.	Parameters	Units	Comp. 1	Comp. 2	Comp. 3	Comp. 4	Comp. 5	Comp. 6
1	Equipment no.	-	AC 01	AC 02	AC 03	AC 04	AC 05	AC 06
2	Make	-	Ingersoll Rand	Ingersoll Rand	Ingersoll Rand	Ingersoll Rand	KFC	Elgi
3	Type	-	Screw	Screw	Reciprocating	Reciprocating	Reciprocating	Reciprocating
4	Capacity	HP	40	10	10	7.5	1.0	5.0
5	Motor Power	kW	22	11	7.5	5.5	0.75	3.7
6	Total Current	A	43	23	11	8	0.5	5.2

Table 5 (b). Vacuum Compressor Details

Sr. No.	Location of Vacuum Compressor	Equipment No	Make	Type	Capacity (HP)	Motor Power (Kw)	Total Current (A)
1	Ward No 21 to 28	VC 01	Ingersoll Rand	Reciprocating	10	7.5	13
2	Ward No 21 to 28	VC 02	Ingersoll Rand	Reciprocating	10	7.5	13
3	CVTS	VC 03	Ingersoll Rand	Reciprocating	10	7.5	13
4	Ward No 10 & 11	VC 04	Ingersoll Rand	Reciprocating	10	7.5	13
5	Operation Theatre	VC 05	Ingersoll Rand	Reciprocating	05	3.7	8
6	OT	VC 06	Ingersoll Rand	Reciprocating	02	1.5	2.6
7	CASUALTY	VC 07	Ingersoll Rand	Reciprocating	02	1.5	2.6
8	ICU	VC 08	Ingersoll Rand	Reciprocating	02	1.5	2.6

Table 6. Air Dryer Details

Sr. No.	Parameters	Units	Air Dryer
1	Refrigerant	-	R22
2	Max. Temperature	°C	60
3	Max. Ambient Temperature	°C	50
4	Max. Inlet Pressure	barg	14

Another important part of the air/vacuum compressor and its system is the leakages present in the compressed air distribution and utilization system such as Pipeline, joints, end applications, etc. As we already know that 90% of the input energy to the compressor is wasted, leakages in the system will waste a significant amount of energy. A normal and healthy compressed air system consists of leakages of a quantity of maximum of 10% of the compressor rated quantity.

Energy Savings Recommendations:

1. Energy Savings due to arrestation of compressed air leakages in the system

During the audit, many air leakages were observed in the compressed air system. Assuming the diameter of the leak to be 1 mm at 7.5barg air pressure, the air leakage is approximately equal to 2.3cfm. Considering the specific energy consumption of the air compressor to be 0.18 kW/cfm. The power losses due to 10 leakages of 1 mm diameter is given below.

Table 7. Arrestation of compressed air leakages in the system

Sr. No.	Parameters	Units	Values
1	Diameter of leakage	mm	1
2	Pressure of Air	barg	7.5
3	Number of Leakages	nos.	5
4	Air flow through a single leak point*	cfm	2.3
5	Specific Energy Consumption of Air Compressor	kW/cfm	0.18
6	Total power losses due to leakages	kW	4.14
7	Daily Operating Hours	hours	10
8	Annual Working Days	days	313
9	Annual Energy Savings	kWh/year	6479
10	Electricity Tariff	Rs./kWh	14.42
11	Annual Cost Savings	Rs./year	93,427

*<https://www.tlv.com/global/TI/calculator/air-flow-rate-through-orifice.html>

In actual, the quantity of the leakages will be more and the diameter of the leakage might be less or more. However, it is also recommended to conduct a detailed online compressed air leakage detection of the whole plant. This audit is conducted using Ultrasonic Leak Detector which detects ultrasonic sound released by small leakages which are unheard by a human.

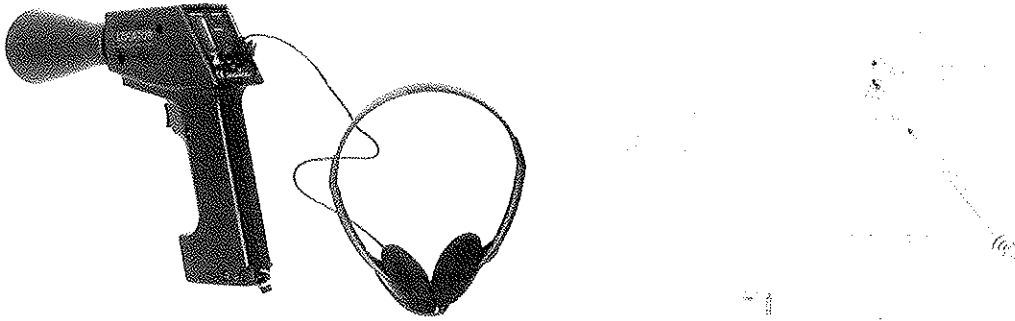

Figure 3. Ultrasonic Compressed Air Leakage Detection

2. Cut-off pressure reduction instead of Pressure Reducing Valve

Artificial demand of the compressors is the additional volume of air which is required because of end uses where air is not regulated, which is the result of supplying the air at a higher pressure than required for any application. Artificial demand increases the supply pressure which directly increases the power consumption of the air compressors.

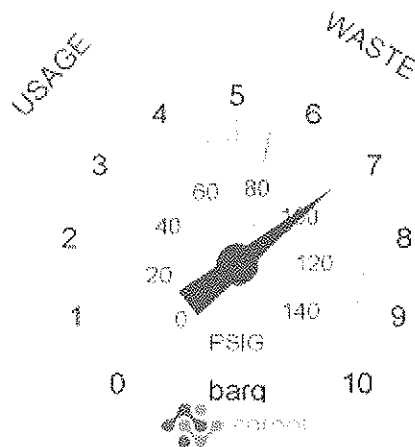

Figure 4. Artificial Demand of Air Compressor

Presently, the cut-off pressure of the larger capacity air compressor is 7.8 kg/cm². The required air pressure is less than 6.5 kg/cm². Reduction of the cut-off pressure from 7.8 to 7 kg/cm² will give a significant amount of savings. Presently, the pressure reduction is done

using a pressure reducing valve which is not a good energy efficiency practice. Savings due to the reduction of cut-off pressure of the compressor is given below.

Table 8. Cut-off pressure reduction instead of Pressure Reducing Valve

Sr. No.	Parameters	Units	Values
1	Cut-off Pressure	bar (g)	7.8
2	Proposed unloading pressure	bar (g)	7
3	Proposed loading pressure	bar (g)	6.5
4	Power consumption after reducing the cut-off pressure by 0.5 bar (g)	%	3
5	Power reduction due to reduction of cut-off pressure by 0.8 bar (g)	%	4.8
6	Present daily consumption**	kWh	192.14
7	Daily Operating Hours	hours	10
8	Annual Working Days	days	261
9	Annual Energy Savings	kWh/year	1204
10	Electricity Tariff	Rs./kWh	14.42
11	Annual Cost Savings	Rs./year	17,361

**As per Bureau of Energy Efficiency*

***Assuming 70% loading of the air compressor*

8.4 Lighting System (Indoor & Outdoor)

Lighting is the other important system present in the premise which is highly energy intensive. Fluorescent tubelights and CFL were observed commonly in the facility. The facility has already replaced these lights with energy efficient tubelights.

Energy Savings Recommendations:

- **Replacement of existing CFL and Fluorescent tubelights with LEDs**

However, there is still a 10% scope of replacement of the remaining CFL and tubelights with LEDs. Direct reduction in power consumption by 90 % is achieved with the replacement. This will also reduce the maximum demand of the whole plant by the same amount. As LEDs are semi-conductor devices, there is also a reduction in power factor improvement capacitor requirements in the facility.

Table 9. Total Replacement of existing lighting system with LEDs

Sr. No.	Parameters	Units	Values
1	Approximate power savings	kW	99
2	Daily Operating Hours	Hours	10
3	Annual Operating Days	days	313
4	Electricity Tariff	Rs./kWh	14.42
5	Annual Electricity Savings	kWh	307870
6	Annual Cost Savings	Rs./year	4468325
	10% Saving scope	Rs./Year	446832

8.5 Hot Water Generation

Hot water is required in the whole facility for different purposes like bathing, cooking and washing. Presently, there is no provision of central hot water system. Instead, different electric heaters are available. Hostels, VIP Rooms, Hospital building and canteen are the locations where hot water is required. The present hot water requirement based on the geyser capacity is given below.

Table 10. Hot water requirements

Geyser Capacity (litres)	Quantity	Total Capacity (litres)
6	53	318
10	29	290
15	7	105
25	4	100
35	7	245
50	71	3550
100	6	600
175	1	175
Total	178	5383

Based on the total geyser capacity, total hot water generation = 5383 litres. Considering an additional 30% usage of water giving a total of 7011 litres. Assuming this value of hot water required throughout the day.

Energy Savings Recommendations:

- **Use of Solar Evacuated Tube Water Heater with Hot Water Generation (At Laundry, CSSD & Hostel)**

Solar water heating will generate hot water free of cost with only a small power consumption of the feed water pump. Initial investment will be a little high. However, after the payback period is over, free hot water will be generated without any consumption of electricity. For generation of 7011 litres of hot water every day, following is the energy savings achieved using solar water heater.

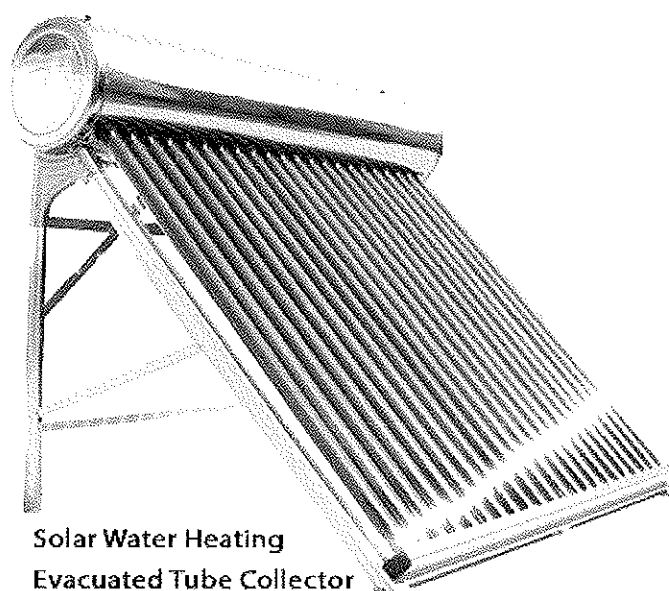

Figure 5. Solar Evacuated Water Heater

Table 11. Solar Evacuated Tube Water Heater

Sr. No.	Parameters	Units	Values
1	Hot water required @ 55°C	litres/day	7011
2	Annual Solar Radiation Incident	kWh/m ² -year	1748.62
3	Annual Thermal Energy required for 7011 litres hot water	kWh/year	1,08,363.4
4	Thermal Efficiency of Solar Water Heater	%	65
5	Maximum Area of Solar Water Heater required	m ²	516.1
6	Annual Power Consumption of Geysers with 97% efficiency of geyser	kWh/year	1,11,714.8
7	Annual Cost savings with replacement	Rs./year	16,10,927

- **Use of Heat Pump for Hot Water Generation (At Laundry, CSSD & Hostel)**

Another alternative to the generation of hot water to solar water heater is a Heat Pump. Heat pump is similar to a refrigerator in construction. The only difference is that the hot side of the system is utilised in a heat pump to supply heat to a space, whereas the cold side of the system is utilised in a refrigerator to remove heat from a space. The electrical energy input to the heat pump is less than the thermal energy output because of its working cycle principle which is represented by COP. COP of a heat pump is the ratio of Thermal Energy supplied to the Electrical Energy Input. Therefore, for the same amount of heat supply, the energy input is lesser than electrical heater/geyser.

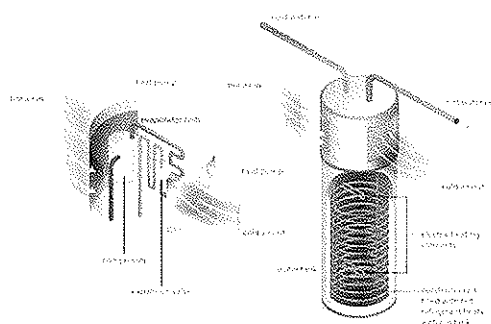

Figure 6. Heat Pump

A centralised heat pump system can be installed for meeting the hot water requirement of the whole facility or individual heat pump units can be installed for each building. The savings associated with the use of heat pump for hot water generation is given below.

Table 12. Heat Pump for Hot Water Generation

Sr. No.	Parameters	Units	Values
1	Hot water required @ 55°C	litres/day	7011
2	Annual Thermal Energy required for 7011 litres hot water	kWh/year	1,08,363.4
3	Annual Power Consumption of Geysers with 97% efficiency of geyser	kWh/year	1,11,714.8
4	COP of a Heat Pump	-	3
5	Annual Electrical Energy input of Heat Pump	kWh/year	36,121.1
6	Annual electrical energy savings	kWh/year	72,242.3
7	Electricity Tariff	Rs./kWh	14.42
8	Annual Cost Savings	Rs./year	10.41.733

A combined system consisting of Solar Evacuated Water Heater along with Heat Pump can be used in hybrid combination, thus optimising both renewable as well as energy efficient technology.

8.6 Air Conditioning System

Different buildings in the facility have split/window and duct-able air conditioning units. These air conditioners being smaller ratings have little scope unlike centralized chillers for applying means of energy saving like use of VFDs on AHUs and secondary pumps.

Present day VRF systems which are energy efficient find use only when the interiors are predesigned according to the VRF requirements.

Presently, VRV system of 148 HP is installed in the facility. However, medical college building and library area have split/window ACs. Also, some of the window/split ACs installed are with low BEE star rating.

Energy Savings Recommendations:

- **Replacement of existing split/window ACs with VRV system**

Replacement of existing split/window ACs with a VRV system of an equal size will give energy savings. The amount identified for the replacement of the AC is 240 HP which can be replaced with an equal amount of VRV system. The energy savings achieved with the same is given below.

Table 13. Replacement of Split/Window ACs with VRV system

Sr. No.	Parameters	Units	Values
1	Approximate power savings	kW	35.8
2	Daily Operating Hours	Hours	10
3	Annual Operating Days	days	313
4	Electricity Tariff	Rs./kWh	14.42
5	Annual Electricity Savings	kWh	1,12,054
6	Annual Cost Savings	Rs./year	16,15,818

- **Replacement of existing split/window ACs with 5-star inverter split ACs**

Existing split/window ACs can be replaced with 5-star inverter split ACs. Assuming presently all the split/window ACs are 3-star rated. The energy savings associated with the replacement of the same is given below.

Table 14. Replacement of Split/Window ACs with 5-star inverter split ACs

Sr. No.	Parameters	Units	Values
1	Existing 3-star split AC ISEER	-	3.55
2	5-star split inverter AC ISEER	-	4.75
3	Annual energy savings	%	33.8
4	Present split/window AC capacity	TR	228
		kW	228
5	Power savings	kW	77.06
6	Daily Operating Hours	Hours	10
7	Annual Operating Days	days	313
8	Electricity Tariff	Rs./kWh	14.42
9	Annual Electricity Savings	kWh	2,41,210
10	Annual Cost Savings	Rs./year	34,78,248

• Solar Thermal VRF System Retrofit

In solar hybrid air-conditioning system, refrigerant vapour from the compressor is further superheated through the solar energy. There is insulated container containing water, and this water is heated through solar energy. Refrigerant vapour in tubes will pass through this hot water chamber and therefore refrigerant vapour is superheated. Hot water inside the chamber can work for 8 h if the water is heated through solar panel for 4 to 5 h inside a well-insulated tank.

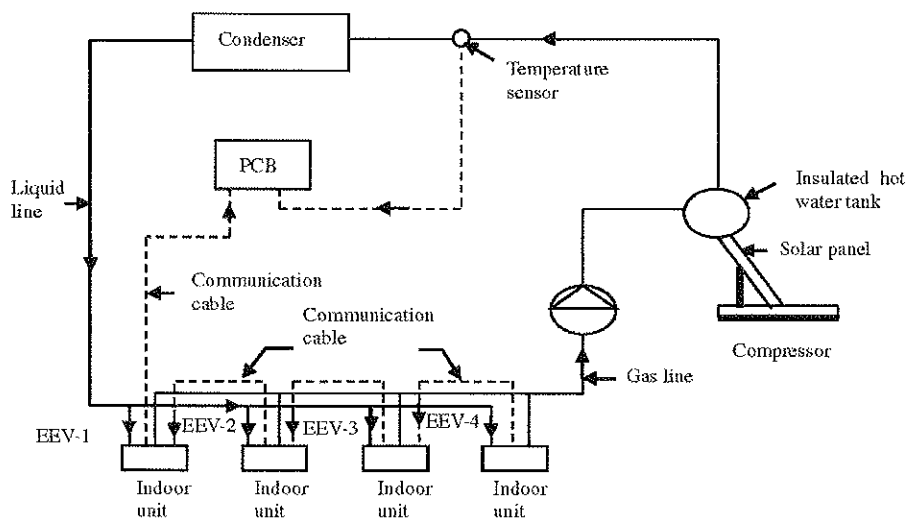

Figure 7. Schematic of Solar Thermal VRF Hybrid System*

*Source - Experimental analysis of a solar thermal hybrid VRF system for maximum energy economy based on Delhi (India) climate, S. Hasan, Mohd. E. Khan, Mohd. Parvez, Energy Sources, Part A, 05 Sept. 2019

As per different experiments and studies, it was found that the savings for different compressor loadings is approximately 50%. However, these savings will change as per the availability of solar energy. Average monthly solar radiation for the site is given below.

Energy Savings Calculation:

Table 15. Energy Savings – Solar Thermal Hybrid VRF System

Month	Solar Radiation (kWh/m ² /day)	% Solar Radiation variation	No. of Days	Consumption of VRF (kWh/month)*	Electricity Savings (kWh/day)*
January-18	4.95	0.73	30	3545	1239
February-18	5.83	0.86	31	7232	2979
March-18	6.44	0.95	31	13687	6220
April-18	6.80	1.00	28	19344	9282
May-18	6.80	1.00	31	23906	11475
June-18	3.95	0.58	31	9941	2773
July-18	2.85	0.42	30	2152	433
August-18	2.55	0.38	31	1590	286
Spetember-18	3.87	0.57	31	5702	1557
October-18	4.15	0.61	30	9689	2840
November-18	4.88	0.72	31	7500	2586
December-18	4.37	0.64	30	3166	977
Total				1,07,454	42,647

*These values are based on assumptions of Actual Cooling Degree Days

- Total Annual Electrical Energy Savings = 42,647 kWh
- Percentage Savings = 39.68 %
- Total Annual Electrical Cost Savings = Rs. 6,14,949/- (Rate- 14.42 Rs./Kwh)
- Simple Payback Period = < 2 YEARS

8.7 Implementation Methodology

Following suggested implementation priority can be adopted.

Priority 1: Recommendations with No/Minor Investment

- Arrest compressed air leakages regularly.
- Improve air intake of compressor with improved ventilation
- Remove PRV and reduce compressor delivery end pressure – see performance on trial basis
- Modify hostel door with insertion type key locks for every room so that no appliances like geysers and lights, fans and AC units remain ON in absence of occupants.

Priority 2: Recommendations with Mid Term Investment

- Decide for implementation of replacement of existing AC with STAR rated AC units.
- Installation of LED type light fitting.
- Work out single DG set of 625 KVA instead of Running two inefficient DG set.
- Work out for reduction of Sanction Demand from MSEDCL.

Priority 3: Recommendations with Long Term Investment

- Installation of PV Solar system at roof top.
- Installation of Solar Water Heating (SWH) system.
- Installation of VRV system for AC.
- Installation of Solar Hybrid VRF System

8.8 Additional Energy Savings Recommendations

Good maintenance practices and some good working practices can reduce energy consumption. The details of the some of the practices are given below.

8.8.1 Electricity

- Optimize the tariff structure with utility supplier
- Schedule your operations to maintain a high load factor
- Minimize-Maximum demand by tripping loads through a demand controller
- Stagger star-up times for equipment with large starting currents to minimize load peaking.
- Use standby electric generation equipment for on-peak high load periods.
- Correct power factor to at least 0.95 under rated load conditions.

- Relocate transformers close to main loads.
- Use optimum setting for transformer taps.
- During no active load, disconnect primary power to transformers.
- Consider on-site DG generator.
- Keep dedicated meter for utility electric meter.
- Use Energy saver mode, Switch off computers & printers when not in use.

8.8.2 Motors

- Properly size to the load for optimum efficiency.
- Where ever possible, use energy efficient motors.
- Improve power factor by using synchronous motors.
- Keep regular check of alignment.
- Always carry rewinding carefully, and do restoration of demand efficiency. Incorrect rewinding results into reduction into the efficiency by 5 to 8%.
- Provide proper ventilation to the motor running areas.
- Regularly keep check point for low voltage and high voltage conditions.
- Keep check & balance all the 3 phase power supply.

8.8.3 Drives

- Use variable speed drives, for Large variable loads.
- High efficiency gear sets must be use.
- Do proper alignment with precision.
- Regularly maintain belt tension as required.
- Eliminate variable pitch pulleys.
- Use Flat belts which are better than v-belts.
- For Large gearboxes use Synthetic lubricants, which are better.
- Eliminate eddy current couplings.
- When not in use, Shut them off.

8.8.4 Fans

- For fan intakes use smooth, well-rounded air inlet cones. At the fan inlet, avoid poor flow distribution.
- Regularly clean screens, Filters & fan blades.
- Do not keep any obstructions at Fan Inlet and outlet.
- Aerofoil shape fan blades are more efficient.

- Use low slip/fan belts, maintain fan speed.
- Maintain belt tension regularly as required.
- Eliminate variable pitch pulleys.
- For large variable fan loads use variable speed drives.
- Where there is continuous operation, use energy-efficient motors.
- Minimise bend work and eliminate leaks in ductwork.
- When not in use, switch off fans.

8.8.5 Blowers

- For air Intakes, use cone & ducts for smooth & rounded air inlet.
- Remove obstructions from blower inlet and outlet points.
- Regularly, clean screens & filters. Replaced essentially.
- Maintain Blower speed.
- Keep belt tension as required, use standard OEM suggested belts with low-slip or no-slip.
- Eliminate variable pitch pulleys.
- Use variable speed drives for large variable blower loads.
- Use energy-efficient motors for continuous operation.
- Turn blowers off when they are not in use

8.8.6 Pumps

- To minimize throttling modify pumping. Operate those near best efficiency point.
- Adapt to side load variation with variable speed drives or sequenced control of smaller units.
- Don't run spare pump with regular pump for pressure delivery. Add an auto start for an on line spare and if needed add a booster pump in the problem area.
- Booster pumps are great solution for small load as requiring higher pressures.
- To reduce pumping rates, increase fluid temperature differentials.
- Keep seals and packing in good condition, to minimize leakages / water waste.
- Balance the system, to minimize flows and reduce pump power requirements.
- Use siphon effect.

8.8.7 Air Compressors

- As per OEM recommendation, use synthetic lubricants. For positive displacement compressors maintain variable speed drive for variable load.
- Maintain lubricating oil temperatures not too high and not too low.
- Maintain oil filter regularly.
- For proper functioning inspect compressor intercoolers regularly.
- Re utilise water heat from a large compressor to power an absorption preheat process feeds.
- Develop and maintain efficiency calculation maintenance program.
- Do energy audit and take follow-up of same.
- Make an efficiency maintenance program as a part of your continuous assessment.

8.8.8 Compressed Air System

- Install a control system to co-ordinate multiple air compressors.
- For operating multiple air compressors with most efficient mode - Study part-load characteristic and cycling costs.
- Match the connected load -Avoid over sizing.
- Load up modulation-controlled air compressors. (They use almost as much power at partial load as at full load.)
- Turn off the back-up air compressor until it is needed.
- Reduce air compressor discharge pressure to the lowest acceptable setting.
- Use the highest reasonable dryer dew point settings.
- Turn off refrigerated and heated air dryers when the air compressors are off. Use a control system to minimize heatless desiccant dryer purging.
- Minimize purges, leaks, excessive pressure drops and condensation accumulation.
- Use drain controls instead of continuous air bleeds through the drains.
- Consider engine-driven or steam-driven air compression to reduce electrical demand charges.
- Replace standard V-belts with high-efficiency flat belts as the old V-belts wear out. Use a small air compressor when major production load is off.
- Take air compressor intake air from the coolest location.
- Use an air-cooled after cooler to heat building makeup air in winter, ensure foul for heat exchangers.
- Be sure that air / oil separators are not fouled.

- Clean regularly filters. Replace it regularly/when alarm. Across suction and discharge of filters Regularly monitor pressure drops.
- Use properly sized compressed air storage receiver.
- Minimize disposal costs by using lubricant that is fully demulsible.
- Find out alternatives to compressed air and use same where ever possible. Example; Blowers for cooling, Hydraulic in place of air cylinders, electric in place of air actuators & pneumatic controls.
- Use nozzles or venturi - type devices instead of blowing with open compressed air lines.
- Check for leaking drain valves on compressed air filter / regular sets. Certain rubber-type valves may leak continuously after they age and crack.
- Industry environments, control packaging lines with high-intensity photocell units instead of standard units with continuous air purging of lenses and reflectors.
- Do an energy audit and follow-up the findings.
- Establish efficiency & maintenance scheduled programs for compress Air. Make it a part of your continuous energy management program.

8.8.9 Chillers

- Set point check and maintain for chilled water temperature.
- Use the low temp. Condenser water available that the chiller can handle.
- Increase the evaporator temperature.
- When fouled, clean heat exchangers.
- Replace whenever essential old chillers/compressors with new higher-efficiency models.
- Use water-cooled in place air-cooled chiller condensers.
- Use energy-efficient motors for continuous operation.
- Specify for condenser – 'Fouling factors' clean or replace filters promptly upon alarm.
- Overcharging of oil is not correct.
- To co ordinate multiple chillers, install a control system.
- To determine most efficient mode for operating multiple chillers, perform the study part for knowing load characteristics & cost of cycle.
- Run the chillers to near base load for the lowest operating costs. Over sizing to match the connected load must be avoided.
- Off line chillers & cooling towers must be isolated.
- Do an energy audit and follow-up the findings.

- Establish a efficiency & maintenance scheduled programs for chillers. Make it a part of your continuous energy management program.

8.8.10 Heating, Ventilation and Air Conditioning

- Tune up the HVAC control system.
- Consider installing a building automation system (BAS) or energy management system (EMS) or restoring an out-of-service one.
- Balance the system to minimize flows and reduce blower / fan / pump power requirements.
- Eliminate or reduce reheat whenever possible.
- Use appropriate HVAC thermostat setback.
- Use morning pre-cooling in summer and pre-heating in winter (i.e. – before electrical peak hours).
- Use building thermal lag to minimize HVAC equipment operating time.
- In winter during unoccupied periods, allow temperature to fall as low as possible without damaging stored materials.
- Improve control and utilization of outside air.
- Use air-to-air heat exchangers to reduce energy requirements for heating and cooling of outside air.
- Reduce HVAC system operating hours (e.g. – night, weekend). Optimize ventilation.
- Ventilate only when necessary. To allow some areas to be shut down when unoccupied, install dedicated HVAC systems on continuous loads (e.g. – computer rooms).
- Provide dedicated outside air supply to cleaning rooms, combustion equipment, etc. to avoid excessive exhausting of conditioned air.
- In dry climates, use evaporative cooling.
- During unoccupied periods, reduce humidification or dehumidification. Use atomization in place of steam for humidification. Clean HVAC unit coils periodically & Comb mashed fins.
- To reduce pressure drop, upgrade filter banks it lower fan power requirements. Monthly check HVAC filters and clean, change if appropriate.
- For proper operation cycle and maintenance check pneumatic controls air compressors.
- Use high-speed doors or clear PVC strip curtains to isolate air conditioned loading dock areas and cool storage areas.

- In high bay areas, install ceiling fans to minimize thermal stratification.
- In areas with high ceilings, relocate air diffusers to required heights. Possible, then reduce ceiling heights.
- Eliminate obstructions in front of radiators, baseboard heaters, etc.
- For dust and vapor control, use professionally designed ventilation hoods.
- Use spot cooling and heating
- Purchase only high-efficiency models for HVAC window units. Use time controller, for HVAC window units.
- Short cycle is the result of oversized units in poor humidity control, so don't oversize cooling unit.
- Install multi-fuelling capability and run with the cheapest fuel available at the time. Consider dedicated make-up air for exhaust hoods.
- Minimize HVAC fan speeds.
- In humid climates, consider desiccant drying of air to reduce cooling requirements.
- Seal leaky HVAC ductwork & around coils.
- Repair loose or damaged flexible connections including those under air handling units.
- Eliminate simultaneous heating and cooling during seasonal transition periods.
- Zone HVAC air and water systems to minimize energy use.
- Keep regular check on damper blades and linkages.
- Do an energy audit and follow-up the findings.
- Establish efficiency & maintenance scheduled programs for HVAC system. Make it a part of your continuous energy management program.

8.8.11 Refrigeration

- Use water-cooled condensers rather than air-cooled condensers. Challenge the need for refrigeration, particularly for old batch processes. Avoid over sizing – match the connected load.
- Consider gas-powered refrigeration equipment minimise electrical demand charges.
- Use “free cooling” to allow chiller shutdown in cold weather. Use refrigerated water loads in series if possible.
- Convert firewater or other tanks to thermal storage.
- Don't assume that the old way is still the best – particularly for energy-intensive low temperature systems.
- Correct inappropriate brine or glycol concentration that adversely affects heat transfer and / or pumping energy. If it sweats, insulate it, but if it is corroding, replace it first.
- Make adjustments to minimise hot gas bypass operation. Inspect moisture / liquid indicators.
- Consider change of refrigerant type if it will improve efficiency. Check for correct refrigerant charge level.
- Inspect the purge for air and water leaks.
- Establish a refrigeration efficiency-maintenance program. Start with an energy audit and follow-up, and then make a refrigeration efficiency-maintenance program part of your continuous energy management program.

8.8.12 Cooling Towers

- Control cooling tower fans based on leaving water temperatures.
- Control to the optimum water temp. as determined from CT and chiller performance.
- Use two-speed or variable-speed drives for cooling tower fan control if the fans are few. Stage the cooling tower fans with on-off control if there are many.
- Turn off unnecessary cooling tower fans when loads are reduced.
- Cover hot water basins (to minimize algae growth that contributes to fouling). Balance flow to cooling tower hot water basins.
- Periodically clean plugged cooling tower water distribution nozzles. Install new nozzles to obtain a more-uniform water pattern.
- Replace splash bars with self-extinguishing PVC cellular-film fill.
- An old counter flow cooling towers, replace old spray-type nozzles with new square-spray ABS practically-non-clogging nozzles.

- Replace slat-type drift eliminators with high-efficiency, low-pressure-drop, self-extinguishing, and PVC cellular units.
- If possible, follow manufacturer's recommended clearances around cooling towers and relocate or modify structures, signs, fences, etc. that interfere with air intake or exhaust.
- Optimize cooling tower fan blade angle on a seasonal and / or load basis.
- Correct excessive and / or uneven fan blade tip clearance and poor fan balance. Use a velocity pressure recovery fan ring.
- Divert clean air-conditioned building exhaust to the cooling tower during hot weather. Re-line leaking cooling tower cold water basins.
- Check water overflow pipes for proper operating level. Optimize chemical use.
- Consider side stream water treatment.
- Restrict flows through large loads to design values. Shut off loads that are not in service.
- Take blow down water from the return water header. Optimize blow down water from the return water header. Automate blow down to minimize it.
- Send blow down to other uses (Remember, the blow down does not have to be removed at the cooling tower. It can be removed anywhere in the piping system.) Implement a cooling tower winterization plan to minimize ice build-up.
- Install interlocks to prevent fan operation when there is no water flow.
- Do an energy audit and follow-up the findings.
- Establish a efficiency & maintenance scheduled programs for Cooling tower. Make it a part of your continuous energy management program.

8.8.13 Lighting

- Reduce excessive illumination levels to standard levels using switching; delamping, etc. (Know the electrical effects before doing delamping.)
- Aggressively control lighting with clock timers, delay timers, photocells, and / or occupancy sensors.
- Install efficient alternatives to incandescent lighting, mercury vapour lighting, etc. as follows: low pressure sodium, high pressure sodium, metal halide, fluorescent, and mercury vapour, incandescent.
- Consider high power factor and long-term efficiency for the selection of ballasts and lamps.
- Consider day lighting, skylights wherever possible.
- Consider painting the walls a lighter colour.
- Using less lighting fixtures, lower watts.
- Use task lighting and reduce background illumination.
- Cross verify regularly, exterior lighting system w r t festivals and events.
- Always provide LED signs and not incandescent.

8.8.14 Solar PV Plant

- Periodic cleaning of solar modules is necessary to get maximum possible output from the system.
- Cleaning must be done preferably with water or a wet cloth.
- Periodic checking of the inverter must be done for any degradation in its performance.
- Thermal checking of the module either yearly or half-yearly must be done for detection of any thermal hotspots in the panels and if possible replacement of the same.
- DC side periodic efficiency check of a solar module must be done and I-V characteristics must be determined for any loss in efficiency.
- Any failure in the solar module structures must be repaired as soon as possible, so as to avoid damage to the solar modules.

8.8.15 DG Sets

- Always use it optimistically for loading.
- Use waste heat for recovery.
- Use heat for jacket and head cooling water for process needs.
- Clean air filters regularly.
- Insulate exhaust pipes to reduce DG set room temperatures.
- Use good quality fuel oil as recommended.

8.8.16 Buildings

- Handle exterior with respect to green building norms.
- Thermal doors, thermal window, roofing insulation are better solution
- Use windbreakers near main doors, exterior doors.
- Install Insulating glasses
- Replace single pane glasses.
- Inside building, use insulated wall panels for covering window and skylight areas.
- Consider replacing exterior windows with insulated glass block, if visibility is not required. It will provide light.
- For sunlit exterior windows : tinted glass, reflective glass, coatings, awnings, overhangs, draperies, blinds and shades are solutions.
- Use landscaping to advantage.
- For primary doors add vestibules &/or revolving doors.
- At high-traffic passages consider automatic doors, air curtains, strip doors, etc.
- Self-closing doors uses is a good option.
- Address minimisation of building stack effect. Use intermediate doors in stairways and vertical passages.
- Use dock seals at shipping and receiving doors.

8.8.17 Waste & Waste Water

- Fix up water leaks.
- Promptly repair leaking toilets and faucets.
- Balance closed systems to minimize flows and reduce pump power requirements. Eliminate once-through cooling with water.
- Use the least expensive type of water source that will satisfy the requirement.
- Reduce flows at water sampling stations.
- Eliminate continuous overflow at water tanks.
- Recycle water, particularly for uses with less-critical quality requirements.
- Recycle water, especially if sewer costs are based on water consumption.
- Do not use a heating system hot water boiler to provide service hot water during the cooling season – install a smaller, more-efficient system for the cooling season service hot water.
- If water must be heated electrically, consider accumulation in a large insulated storage tank to minimize heating at on-peak electric rates.
- Use multiple, distributed, small water heaters to minimize thermal losses in large piping systems.
- Use the lowest possible hot water temperature.
- Install pre-treatment to reduce TOC and BOD surcharges.
- Consider leased and mobile water treatment systems, especially for deionised water.
- Seal sumps to prevent seepage inward from necessitating extra sump pump operation.
- Test for underground water leaks. (It's easy to do over a holiday shutdown.)
- Check water overflow pipes for proper operating level.
- Provide proper tools for wash down – especially self-closing nozzles.
- Verify the water meter readings.
- Use water restrictors on faucets, showers, etc. Use self-closing type faucets in restrooms.
- Install efficient irrigation.

8.8.18 Miscellaneous

- All the utilities must be meter and monitored for its optimum use.
- Efficiency must be regularly checked.
- Know the causes of deviations and take prompt action on same.
- Shut down spare equipments, idling or unneeded equipment.
- Make sure that all of the utilities to redundant areas are turned off and those are like compressed air, cooling water, etc.
- Install automatic control to efficiently co-ordinate multiple air compressors, chillers, cooling tower cells, boilers, etc.
- To reflect current loads and variations, renegotiate utilities contracts.
- To handle pick demand, consider nearby sources for buying utilities.
- Consider alternatives to high pressure drops across valves.
- Consider upgrades if your lease will continue for several more years.
- Adjust fluid temperature within acceptable limits to minimise undesirable heat transfer in long pipelines.
- Minimise use of flow bypasses and minimise bypass flow rates.
- Provide restriction orifices in purges (nitrogen, steam, etc.).
- Eliminate unnecessary flow measurement orifices.

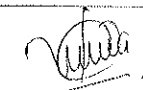

REPORT

GREEN AUDIT REPORT

FOR KIMSOU

July 2019

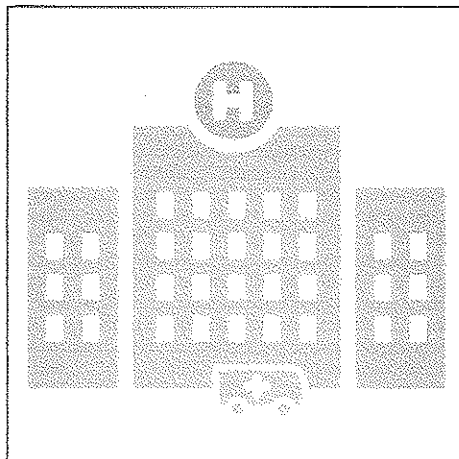

Submitted to:

*Krishna Institute Of Medical Sciences,
"Deemed To Be University", Karad
Malakapur, Tal: Karad,
Dist: Satara,
Maharashtra*

Submitted by:

*Green Scientific Development (I) Pvt.
Ltd.
4/A Wing, Bldg No. 23,
Tulsi C.H.S. Ltd, Subhash Nagar,
Chembur, Mumbai - 400071
greenscientificdevelopment@gmail.com*

Date: 18 July 2019

A handwritten signature in black ink, appearing to read 'Nandha'.

REGISTRAR
Krishna Institute of Medical Sciences
"Deemed To Be University", Karad

Contents

1.0	INTRODUCTION	6
1.1	PREEMBLE	7
1.2	SCOPE & OBJECTIVE OF AUDIT	7
1.3	BENEFITS OF GREEN AUDIT	8
2.0	TARGET AREAS OF GREEN AUDITING	9
3.0	METHODOLOGY OF GREEN AUDITING	13
3.1	DATA COLLECTION	13
3.2	DATA ANALYSIS	13
3.3	OBSERVATIONS/RECOMMENDATION	13
4.0	AUDIT OBSERVATIONS AND FINDINGS	14
4.1	REGULATORY STATUS AND STANDARDS	14
4.2	WATER AND WASTEWATER MANAGEMENT	15
4.3	ENERGY MANAGEMENT	17
4.4	WASTE MANAGEMENT	36
4.5	GREEN CAMPUS	39
4.6	ROUTINE GREEN PRACTICES:	41
4.7	CARBON FOOTPRINT	43
5	CONCLUSIONS AND RECOMMENDATIONS	44
6	ACKNOWLEDGEMENTS	45
7	ANNEXURE: CAMPUS LAYOUT	46
8	PHOTO GALLERY (KIMSDU CAMPUS)	47

Green Audit Completion Certificate

Name of the Installation **Krishna Institute Of Medical Sciences, "Deemed To Be University", Karad, Satara - 415539**

Details of Facility Audited Hospital, Lab, Hostels, Guest House, Gym, Colleges, University Campus, Cafeteria, Residential Area, Central Library, Waste Facilities, Utilities, Etc.

Date of Green Audit 18 July 2019

Name of Lead Auditor Mr. Kiran Shinde - EMS Lead Auditor

Name of Co-Auditor Mr. Mahesh Chhatre - Environment Expert

Name of Auditing Company **Green Scientific Development (I) Pvt. Ltd.**
4/A Wing, Bldg No. 23, Tulsi C.H.S. Ltd, Subhash Nagar, Chembur, Mumbai – 400071

(Handwritten signature)

Signature of Auditor : -----

Lead Auditor : **Mr. Kiran Shinde**

Certification No : **ISO 14001:2015_35142852 02 Delegate No 168345**

Dated 15.04.2019

Stamp of Company :





**PR315: ISO 14001:2015 Lead Auditor
(Environmental Management Systems)
Training course**

Certificate of Achievement

Mr Kiran M Shinde

has successfully completed the above mentioned course and examination.

11th - 15th March 2019

MUMBAI, INDIA

Certificate No. 35242852 02

Delegate No. 168045

for TUV NORD CERT GmbH

Essen, 2019-04-15

The course is certified by CQI and IRCA (Certification No. 18125). The learner meets the training requirements for those seeking certification under the IRCA EMS Auditor certification scheme

TUV NORD CERT GmbH

Langemannstraße 20

45141 Essen

www.tuv-nord-cert.com



Green Audit Program

Name of Audit Participants

Auditors - External Members			
1	Mr. Kiran Shinde	Lead Auditor	Lead Auditor
2	Mr. Mahesh Chhatre	Co-Auditor	Environment Expert
Auditee - In-house Members			
1	Mr. S. A. Mashalkar	Chair Person	Assistant Registrar - Estate & Security
2	Mr. Tushar Kadam	MR	Office Superintendent
3	Mr. Ganesh Patole	Member	Environmental Supervisor
4	Mr. D. S. Kashid	Member	Civil Supervisor
5	Mr. S. Y. Kirdak	Member	HOD- Garden Dept.
6	Mr. Y. G. Kulkarni	Member	HOD - Power House Dept.

Audit Schedule (18 July 2019)

Heads	From	To	Details
Opening Meeting	9.00	9.45	With Management Team & Auditee
Site Visit	10.00	13.15	Departments
Lunch Hr	13.15	14.00	In House
Site Visit	14.00	18.00	Campus and Utilities
Closing Meeting	18.00	18.45	With Management Team & Auditee

1.0 INTRODUCTION

Krishna Institute of Medical Sciences "Deemed To Be University", Karad is located in Western Maharashtra, India against the background of mountains and valleys. The green, eco-friendly campus is spread over 57 acres and is well connected by rail, road & air.

The University is accredited by NAAC 'A' grade and has been conferred with ISO 9001:2015 certification.

The constituent faculties of the University include Medical, Dental, Physiotherapy, Nursing, Pharmacy and Allied Sciences offering undergraduate and postgraduate courses in the respective faculties. It also runs Ph.D. programs and Post Doctoral Fellowships in various subjects.

The teaching hospital is 1125 bedded multispecialty tertiary care hospital with facilities for Critical Care, Endoscopic Surgeries, Dialysis, Cardiology, Cardio-vascular-thoracic-surgery, Oncology, Urology, Neurosurgery, Plastic surgery, Oral and Maxillofacial Surgery and a recognized Renal Transplant Unit. It has fully equipped major operation theaters, minor theaters, labour rooms, blood bank accredited by NABH, radiodiagnosis and radiotherapy, computerized medical records, counselling services etc. There are separate intensive care units like Medical, Surgical, Coronary care, Pediatric, Neonatal (accredited by Neonatology Forum of India), Respiratory and Obstetrics. The neonatal ICU is recognized by Neonatology Forum of India. The radio-diagnosis department has facilities for MRI, colordoppler, mammography, DSA etc. It also actively participates in national healthcare programs and various extensions and outreach community programs initiated by the Institute.

1.1 PREAMBLE

To identify opportunities for Sustainable Development practices, Green Audit is a great tool. Green Audit helps to enhance all environmental aspects. This also not only helps to achieve values of virtue but also protects in various aspects such as Health, hygiene, safety, reduction in liabilities & saves money. A green audit is a valuable tool for any user in many ways which can be used to improve environmental & economic performance of the Auditee resulting in the enhancement in the reputation. General focus of green audit is to know reduce, reuse, recovery practices and its sustainable status. Baseline data collection and its study is a first step. Then in auditing process, the data serves to identify opportunist for the line of actions and current status of the campus. If performed with standard practices and compared with other audits conducted at similar projects, green audit report help to know programme and activities performances, identify areas for improvement and to decide prioritise for the improvement and implementation in current practices and future expansions. Economical benefits and losses can be calculated with this tool. This can be achieved by establishing rate analysis between current practice Vs standard/optimum utilisation practice cost.

The **aim and goal of organizing Green Audit** is to know sustainable development practice performed at KIMSDU, Karad. Upgrade the environment condition in and around the institutes, Hospital.

1.2 SCOPE & OBJECTIVE OF AUDIT

The general scope of audit is to visit the site, collect available data and prepare a baseline report to study biodiversity, resource management, measures to mitigate pollution, improve resource quality and sustainable practices.

The specific objectives are:

- To know the water aspect,
- To know energy aspect and its status,
- To know all essential aspects such as air, noise, soil, etc for the premises.
- To know the biodiversity and suggest measures to improve the same,
- To suggest sustainable development practices for all the aspects,
- To know the solid waste and its management practices with 3 R principle,

In Nut shell, to encourage values of sustainable development practices through conducting green audit at premises.

1.3 BENEFITS OF GREEN AUDIT

- For stakeholders and society, developing an environmental ethic and value.
- Enhance environment culture, Social Imaging, Profile enhancement for the university.
- Enhances the Environmental awareness through the education, systematic approach towards environmental management.
- Resource management and to know potential scope in same.
- It helps to know the standard of green initiatives in the premises.
- It provide basis for improvement in sustainability aspect. Waste management by knowing practices for reduction of waste generation, solid handling and its management, and water recycle, etc.
- Conformation for the compliances for the applicable conditions, rules and regulations.
- Able to evaluate the cost saving aspects through environmental friendly sound management practices,
- Able to understand any of the forthcoming complications due to changes in the policies, law, act, applicable statutory compliances
- Helps to frame action plan for the best environmental performance,
- Improving environmental standards.
- Benchmarking for environmental protection initiatives.
- Financial savings through a reduction in resource use, penalties and actions.
- Development of ownership, personal involved in the activity.

2.0 TARGET AREAS OF GREEN AUDITING

Green audit forms the part of a resource management process. Although they are individual events, the real value of green audits is the fact that they are carried out, at defined intervals, and their results can illustrate improvement or change over time. Eco-campus concept mainly focuses on the efficient use of energy and water; minimize waste generation or pollution and also economic efficiency. All these indicators are assessed in process of "Green Auditing". Eco-campus focuses on the reduction of contribution to emissions, procures a cost effective and secure supply of energy, encourages and enhances energy use conservation, promotes personal action, reduce the institute's energy and water consumption, reduce wastes to landfill, and integrate environmental considerations into all contracts and services considered to have significant environmental impacts. Target areas included in this green auditing are water, energy, waste and carbon footprint.

❖ Auditing for Water Management

Water is a natural resource; all living matters depend on water. While freely available in many natural environments, in human settlements potable (drinkable) water is less readily available. We need to use water wisely to ensure that drinkable water is available for all, now and in the future. A small drip from a leaky tap can waste more than 180 liters of water to a day; that is a lot of water to waste - enough to flush the toilet eight times. Water contamination and depletion of water table are taking place at recorded negative laps rates. Examining water management practice became a tool to know environmentally sound/responsible practice. Water auditing is conducted for the evaluation of facilities of raw water intake, optimum utilisation, reuse-recycle practice and safe disposal. The concerned auditor investigates the relevant method that can be adopted and implemented to balance the demand and supply of water. It is therefore essential that any environmentally responsible entity examine its water use practices

❖ **Auditing for Energy Management**

Energy cannot be seen, but we know it is there because we can see its effects in the forms of heat, light and power. In the energy Management aspect during auditing following parts are essential to asses; energy sources and its consumption, energy consumption and losses monitoring practices, lighting & appliances facilities, etc. Energy aspect required to be assessed and have importance in the auditing practice to know the sustainability. An old incandescent bulb uses approximately 60W to 100W while an energy efficient light emitting diode (LED) uses only less than 10 W. Energy auditing deals with the conservation and methods to reduce its consumption related to environmental degradation. To analyse environmental responsibility, institution must know there energy practice.

❖ **Auditing for Waste Management**

Pollution from waste is aesthetically unpleasing and results in large amounts of litter in our communities which can cause health problems. Plastic bags and discarded ropes and strings can be very dangerous to birds and other animals. This indicator addresses waste production and disposal, plastic waste, paper waste, food waste, and recycling. Solid waste can be divided into two categories: general waste and hazardous waste.

General wastes include what is usually thrown away in homes such as garbage, paper, tins and glass bottles. Hazardous waste is waste that is likely to be a threat to health or the environment like biomedical waste, cleaning chemicals and fuels. Unscientific landfills may contain harmful contaminants that leach into soil and water supplies, and produce greenhouse gases contributing to global climate change.

Through 3 R principle, one can think and implement solid waste as a resourceful material for its utilisation as secondary source. Thus the minimization of solid waste is essential for sustainable operations of hospital. It is therefore essential that any environmentally responsible entities examine its waste processing practices.

❖ **Auditing for Green Campus Management**

Unfortunately, biodiversity is facing serious threats from habitat loss, pollution, over consumption and invasive species. Species are disappearing at an alarming rate and each loss affects nature's delicate balance and our quality of life. Without this variability in the living world, ecological systems and functions would break down, with detrimental consequences for all forms of life, including human beings. Newly planted and existing trees decrease the amount of carbon dioxide in the atmosphere. Trees play an important ecological role within the urban environment, as well as support improved public health and provide aesthetic benefits to cities. In one year, a single mature tree will absorb up to 21.77 kg. of carbon dioxide from the atmosphere, and release it as oxygen. The amount of oxygen that a single tree produces is enough to provide one day's supply of oxygen for people. So while you are busy studying and working on earning those good grades, all the trees on campus are also working hard to make the air cleaner for us. Trees on our campus impact our mental health as well; studies have shown that trees greatly reduce stress, which a huge deal is considering many students are under some amount of stress.

❖ Auditing for Carbon Footprint

Commutation of stakeholders has an impact on the environment through the emission of greenhouse gases into the atmosphere consequent to burning of fossil fuels (such as petrol). The most common greenhouse gases are carbon dioxide, water vapour, methane, nitrous oxide and ozone. Of all the greenhouse gases, carbon dioxide is the most prominent greenhouse gas, comprising 402 ppm of the Earth's atmosphere. The release of carbon dioxide gas into the Earth's atmosphere through human activities is commonly known as carbon emissions.

An important aspect of doing an audit is to be able to measure your impact so that we can determine better ways to manage the impact. In addition to the water, waste, energy and biodiversity audits we can also determine what our carbon footprint is, based on the amount of carbon emissions created. One aspect is to consider the distance and method travelled between home and hospital every day. It undertakes the measure of bulk of carbon dioxide equivalents exhaled by the hospital through which the carbon accounting is done. It is necessary to know how much the organization is contributing towards sustainable development. It is therefore essential that any environmentally responsible entity examine its carbon footprint.

3.0 METHODOLOGY OF GREEN AUDITING

The methodology adopted for the green audit conducted at KIMSDU was in three step process comprising of ;

3.1 DATA COLLECTION

In preliminary data collection phase data collection is performed. This is carried out by various discussions, communication with responsible persons. Following steps were taken for data collection ;

- Preparation of data sheets in the form of checklist and questionnaire.
- Get the filled data sheets along with essential supporting document.
- Site Visit to all the facilities under audit. Like; Departments, ICUs, OTs, canteen, Library, admin department, Campus, etc.
- Collection of data / general information during visit by observation and spot interviews.
- Sample/Evident collections such as; The power consumption of appliances was recorded by taking an avg. value in some cases.

3.2 DATA ANALYSIS

- Study the regulatory applicable laws and its compliances.
- Collect the data sheet, observations and sample/evidence collected.
- Calculation and compare records maintained for various aspects of water, solid waste, energy (electricity), economics for pollution abatement, standard practices, Trees and species variation and its Quantity, Carbon Foot print and its projection.

3.3 OBSERVATIONS/RECOMMENDATION

Audit Observation and Findings on the basis of data analysis.

4.0 AUDIT OBSERVATIONS AND FINDINGS

The base of any green audit is that its findings are supported by documents and verifiable information. The audit process seeks, on a sampled basis, to track past actions, activities, events, and procedures to ensure that they are carried out according to systems requirements and in the correct manner.

Green audits form a part of a process. Although they are individual events, the real value of green audits is the fact that they are carried out, at defined intervals, and their results can illustrate improvement or change over time.

Although green audits are carried out using policies, procedures, documented systems and objectives as a test, there is always an element of subjectivity in an audit. The essence of any green audit is to find out how well the environmental organisation, environmental management and environmental equipment are performing. Each of the three components is crucial in ensuring that the organisation's environmental performance meets the goals set in its green policy. The individual functioning and the success of integration will all play a role in the degree of success or failure of the organisation's environmental performance.

4.1 REGULATORY STATUS AND STANDARDS

KIMSDU abides by all the environmental regulations applicable to the campus.

- KIMSDU is a registered and having valid license w. r. t. its scope and activity.
- KIMSDU has a valid Consent to Operate received from the Pollution Control Board.
- KIMSDU confirms all the norms lay down by Air Act, Water Act, E-waste, Biomedical waste and Hazardous Waste Rules.

KIMSDU has obtained

- ISO 9001 certification.
- Accreditation of National Assessment and Accreditation Council
- Recognition of National Accreditation Board for Hospitals & Healthcare Providers (NABH)
- Accreditation of National Accreditation Board for Testing and Calibration Laboratories (NABL)

4.2 WATER AND WASTEWATER MANAGEMENT

Table 1.0: Water usage on the campus is tabulated as below:

Sr. No.	Area	Water usage (lit./day)
1	Gardening	2,50,000 recycled from STP
2	Operation Theatres	8,000
3	General Wards	34,000
4	Special Wards	10,000
5	Cleaning	5,000
6	Canteen	8,000
7	Drinking	40,000
8	Toilets	25,000
9	Bathrooms	70,000
10	Washing	50,000
11	Construction work	40,000
12	Office usage	20,000
13	Urinals	12,000
14	Laboratories	28,000
15	Leakages	0
	Total	3,50,000

Note: * STP treated water is used for gardening and landscape

Table 2.0: Other water related data is as follows:

Sr. No.	Aspect	Details
1.	Water and wastewater treatment system.	The hospital have following treatment systems on the premises: <ul style="list-style-type: none"> • Water Treatment Plant of 750 m³/d capacity • Sewage Treatment Plant of 500 m³/d capacity – 2 numbers • Effluent Treatment Plant of 100 m³/d capacity • RWH provided.
2.	Water coolers with drinking water filtration	<ul style="list-style-type: none"> • Aqua guard – 44 Nos. • R.O. systems – 3 Nos. • Coolers – 47 Nos.
3.	Urinals and toilets	<ul style="list-style-type: none"> • Western WC – 710 • Indian WC – 405 • Urinals - 163
4.	Waterless urinals	Nil
5.	Bathrooms	1018 Nos
6.	Water taps	4047 Nos
7.	Water taps in laboratories	327 Nos
8.	Bore wells	7 Nos
9.	Ponds	Nil
10.	Water pumps	<ul style="list-style-type: none"> • 2 Nos of pumps 7.5 HP each for bore • 5 Nos of pumps of 5.0 HP each for bore • 1 pump of 20 HP for river water
11.	Quantity of water pumped	350 m ³ /day
12.	Water charges paid	Rs.33596.65 paid to Lift Irrigation management division, Ogalewadi Karad.
13.	Water tanks for storage	37
14.	Quantity of water stored	1600 m ³

Water Wastage:

Being an environmentally conscious entity KIMSDU is aware of their responsibility and do regular checks for identifying water leakages or wastages. At present there are no leakages or over usages of water identified.

4.3 ENERGY MANAGEMENT**Table 3.0: Collective data on energy**

Sr. No.	Aspect	Details
1.	Electricity charges	Avg. Rs.3314292 /month
2.	Number of gas cylinders used per month	Commercial gas cylinders- 43 Refilling- 23/month
3.	Cost of gas cylinders used (refilling@Rs.1266)	Rs.29118/month
4.	Number of generators	04
5.	Cost of generator fuel	Rs.79510 /month
6.	Total cost of energy	Rs.3422920 /month
7.	Number of CFL bulbs	276
8.	Number of LED lights	4500
9.	Number of Incandescent bulbs	5
10.	Number of fans	3268
11.	Number of air conditioners	552
12.	Total electrical equipment	45
13.	Number of laptops	48
14.	Number of computers	457
15.	Number of printers	193
16.	Number of projectors	60
17.	Number of photocopiers	12
18.	Number of televisions	135
19.	Energy generation using solar panels	108000 kWh/month

Table 4.0: Energy usage by CFL bulbs:

Area	No. of CFL bulbs	Power consumed (Watts)	Power (kW)	Working time (Hrs./day)	Energy usage per month (kWh)
Medical college building	10	80	0.08	8	19.2
All wards and hospital	56	560	0.5	8	134.4
Dental college building	10	80	0.08	8	19.2
All OPDs and HR Office	30	300	0.3	8	72
Library	0	0	0	8	0
Pharmacy college building	2	16	0.01	8	3.8
Nursing college building	6	48	0.04	8	11.5
IHR Hostel (old /new)	11	110	0.11	8	26.4
Women's hostels (1 to 6)	26	260	0.26	8	62.4
Blood bank / Radiotherapy	4	40	0.04	8	9.6
O. T / Physiotherapy college	11	110	0.11	8	26.4
Old Pathology /C.M. Stores	6	60	0.06	8	14.4
Transport	2	60	0.06	8	14.4
Café	4	40	0.04	8	9.6
All staff qtrs.	18	144	0.1	8	34.5
University building	10	100	0.1	8	24
Auditorium / Gym hall	21	210	0.21	8	50.4
Pharmacy (old & new) (KH)	3	30	0.03	8	7.2
Civil maintenance	10	100	0.1	8	24
Krishna bank/ Sarita bazar	32	576	0.5	8	138.2
Canteen	4	40	0.04	8	9.6
Total energy usage per month (kWh)					711.36

Table 5.0: Energy usage by LED bulbs and tubes

Area	No. of LED Bulbs	Power consumed (Watts)	Power (kW)	Working time (Hrs./day)	Energy usage per month (kWh)
Blood Bank	32	576	0.5	8	138.2
Passages	24	432	0.4	8	103.6
Cancer clinic	16	288	0.2	8	69.1
Administration Offices	33	594	0.5	8	142.5
Administration Offices & ICU with passages	42	756	0.756	8	181.44
Passage & Cashier office near Ward No.24	50	900	0.9	8	216
Passages and ward No 15, 16	65	1170	1.17	8	280.8
Ward no. 16, 17, 18 and passages	85	1530	1.53	8	367.2
Ward No. 5, 4, 32	70	1260	1.26	8	302.4

Area	No. of LED Bulbs	Power consumed (Watts)	Power (kW)	Working time (Hrs./day)	Energy usage per month (kWh)
Ward No. 6, 10	59	1062	1.062	8	254.88
Ward No. 9, 17, 18, 10, 8	78	1404	1.404	8	336.96
Ward NO. 11, 7	49	882	0.882	8	211.68
Ward No. 11 passage	10	180	0.18	8	43.2
Ward No. 10 & passage	42	756	0.756	8	181.44
Ward No. 19, 20, 14	65	1170	1.17	8	280.8
Boys Hostel III (2 nd floor)	40	720	0.72	8	172.8
Boys Hostel III (1st floor)	50	900	0.9	8	216
Boys Hostel (Ground floor)	70	1260	1.26	8	302.4
Women Hostel (4th floor)	79	1422	1.422	8	341.28
Women Hostel No. IV (1st floor)	37	666	0.666	8	159.84
Women Hostel No. IV (Ground floor)	51	918	0.918	8	220.32
Women Hostel No. V (3rd floor)	49	882	0.882	8	211.68
Women Hostel No. V (2 nd floor)	42	756	0.756	8	181.44
Women Hostel No. VIII (1st floor)	23	414	0.414	8	99.36
Women Hostel No. V (Ground floor)	87	1566	1.566	8	375.84
Central Library (4th floor)	32	576	0.576	8	138.24
Central Library (3rd floor)	48	864	0.864	8	207.36
Central Library (2 nd floor)	21	378	0.378	8	90.72
Central Library (1st floor)	47	846	0.846	8	203.04
Central Library (Ground floor)	29	522	0.522	8	125.28
Central Library and Nursing Hostel	43	774	0.774	8	185.76
Central Library and Nursing Hostel	52	936	0.936	8	224.64
Dental College Library (4th floor)	45	810	0.81	8	194.4
Dental College (2 nd floor)	34	612	0.612	8	146.88
Pharmacy College (2 nd floor)	66	1188	1.188	8	285.12
Pharmacy College (1st floor)	40	720	0.72	8	172.8
Physiotherapy College (1st floor)	11	198	0.198	8	47.52
Annexure Building (2 nd floor)	51	918	0.918	8	220.32
Annexure Building (3rd floor)	67	1206	1.206	8	289.44
Annexure Building (Ground floor)	30	540	0.54	8	129.6
Pharmacy College (Lab)	4	72	0.072	8	17.28
Annexure Building	35	630	0.63	8	151.2
Ladies hostel No. 3 (3rd floor)	50	900	0.9	8	216
Ladies hostel No. 3 (4th floor)	50	900	0.9	8	216
Ladies hostel No. 4	70	1260	1.26	8	302.4
Nursing College	176	3168	3.168	8	760.32
Ladies hostel near dental college	60	1080	1.08	8	259.2
Dental hostel	134	2412	2.412	8	578.88

Area	No. of LED Bulbs	Power consumed (Watts)	Power (kW)	Working time (Hrs./day)	Energy usage per month (kWh)
IHR hostel	155	2790	2.79	8	669.6
NRI hostel	54	972	0.972	8	233.28
B Type quarters	59	1062	1.062	8	254.88
Laundry & medical college	1400	25200	25.2	8	6048
Medical college and other	389	7002	7.002	8	
Total energy usage per month (kWh)					17759.52

Table 6.0: Energy usage by fans

Area	No. of Fans	Power Consumed (Watts)	Power (kW)	Working Time (Hrs./day)	Energy Usage per Month (kWh)
Medical college	563	65	0.065	8	8782.8
All wards and hospital	482	65	0.065	8	7519.2
Dental college	451	65	0.065	8	7035.6
All OPDs and HR office	251	65	0.065	8	3915.6
Library	95	65	0.065	8	1482
Pharmacy college	117	65	0.065	8	1825.2
Nursing college	151	65	0.065	8	2355.6
Nursing Hostel	47	65	0.065	8	733.2
Guest house (old /new)	24	65	0.065	8	374.4
NRI hostel	56	65	0.065	8	873.6
IHR hostel (old /New)	107	65	0.065	8	1669.2
Women's hostel (1 to 6)	166	65	0.065	8	2589.6
Dental hostel (BDS)	92	65	0.065	8	1435.2
Sr. boys hostel	164	65	0.065	8	2558.4
Jr. boys hostel	73	65	0.065	8	1138.8
Radiology / NARI OPD	54	65	0.065	8	842.4
Krishna bank / Sarita bazar	29	65	0.065	8	452.4
Annexure building	71	65	0.065	8	1107.6
Laundry / Civil maintenance	25	65	0.065	8	390
Café / Transport	8	65	0.065	8	124.8
Pharmacy college	117	65	0.065	8	1825.2
Dental library	43	65	0.065	8	670.8
Swimming pool	6	65	0.065	8	93.6
Old accounts office	3	65	0.065	8	46.8
Old pharmacy	6	65	0.065	8	93.6
New pharmacy	13	65	0.065	8	202.8
Biomedical Engg.	1	65	0.065	8	15.6
Venus hall	9	65	0.065	8	140.4

Area	No. of Fans	Power Consumed (Watts)	Power (kW)	Working Time (Hrs./day)	Energy Usage per Month (kWh)
Physiotherapy college	44	65	0.065	8	686.4
Total energy usage per month (kWh)					50980.8

Table 7.0: Energy usage - Air Conditioners

Area	No. of ACs	Working time (Hrs./day)	Power consumed (kWh/day)	Energy usage per month (kWh)
Radiotherapy				
DS room	1	8	4.2	110.9
Mammography	1	8	3.2	83.2
Panel room	1	24	6.4	166.4
Procedure room	1	8	4.2	110.9
Pathology lab - KH	1	8	3.2	83.2
Administrative Office	1	1	0.8	20.8
Machine room	2	24	192	4992
Chiller room	1	24	96	2496
Seminar hall	2		0	0
Administrative Office	2		0	0
Conference hall	1		0	0
OPD	1	2	0.8	20.8
Administrative office	1	2	1.6	41.6
New Pathology lab - KH	1	24	6.4	166.4
Blood bank				
Blood bank collection room	1	8	2.1	55.4
Quality control - 1	1	24	12.8	332.8
Quality control - 2	1	24	12.8	332.8
Serology	1	24	12.8	332.8
Transmission room	1	24	12.8	332.8
Composition room	1	24	12.8	332.8
Storage room	1	24	12.8	332.8
Quality control - 3	1	24	12.8	332.8
Storage room	1	8	2.1	55.4
HoD Office	1	8	4.2	110.9
Ward 12				
Ward no12 OT	1	8	4.2	110.9
Eclampsia room	1	10	5.3	138.66
ICU	1	24	12.8	332.8
OT and related areas				
OT 8	2	8	6.4	166.4
OT 9	1	8	4.2	110.9

Area	No. of ACs	Working time (Hrs./day)	Power consumed (kWh/day)	Energy usage per month (kWh)
OT No 1	1	8	38.4	998.4
OT No 2	1	8	38.4	998.4
OT No 3	2	8	70.4	1830.4
OT No 4	3	8	374.4	9734.4
OT No 5	2	8	70.4	1830.4
OT No 6	2	8	96	2496
OT No 7	2	8	96	2496
Ward no 13 PICU	2	24	25.6	665.6
SICU	2	24	32	832
Ward and related areas				
Ward 25 MICU	5	24	64	1664
Ward 25 MICU	5	24	32	832
Ward 26 SICU	3	24	48	1248
Ward 26	2	24	25.6	665.6
Ward 26	4	24	25.6	665.6
Ward 16	2	5	5.3	138.6
Ward 1	3	24	48	1248
Ward 1	1	24	9.6	249.6
HOD room	1	8	2.1	55.4
OT	4	20	352	9152
Administrative Office near OT	2	8	4.2	110.9
Cath lab				
Cath lab equipment room - Sec 1	1	24	105.6	2745.6
Cath lab equipment room - Sec 2	1	8	35.2	915.2
Cath lab ICU & Day Care - Sec 1	1	18	64.8	1684.8
Cath lab ICU & Day Care - Sec 2	2	18	43.2	1123.2
Ward 7	1	6	3.2	83.2
Ward 9	1	6	3.2	83.2
Ward 10	1	6	2.4	62.4
Ward 10 burn ICU	2	10	8	208
Ward 11 PR 215	1	8	2.1	55.4
Ward 11 PR 216	1	8	2.1	55.4
Ward 14 HoD	1	24	9.6	249.6
NICU	4	24	51.2	1331.2
Doctor's room	1	8	2.1	55.4
PICU	1	24	12.8	332.8
Doctor's room	1	8	2.1	55.4
Common Room	1	8	3.2	83.2
OT	1	8	51.2	1331.2
Ward 11 new PR room	24	5	144	3744

Area	No. of ACs	Working time (Hrs./day)	Power consumed (kWh/day)	Energy usage per month (kWh)
New eco room	1	8	5.3	138.6
UPS Room	0	24	0	0
New eco room	1	8	2.1	55.4
Radiology building				
MRI control room	1	24	9.6	249.6
Report room	1	10	4	104
HOD cabin	1	8	3.2	83.2
Sonography	2	24	25.6	665.6
CR room	1	8	3.2	83.2
Report room	1	8	3.2	83.2
X RAY machine 6	1	8	3.2	83.2
CT room	2	24	32	832
CT report	1	24	12.8	332.8
X RAY machine 8	1	8	3.2	83.2
DSA room	1	4	1.6	41.6
Seminar room	2	4	3.2	83.2
X ray report	1	8	2.1	55.4
CT UPS	1	24	12.8	332.8
MRI	2	24	192	4992
MRI Machine room	2	24	115.2	2995.2
Chiller room	1	24	384	9984
Pharmacy and related area				
Pharmacy store 1	2	24	25.6	665.6
Pharmacy store 2	2	24	19.2	499.2
Pharmacy server room	1	24	6.4	166.4
Ward 3 CICU 1	2	24	25.6	665.6
Ward 3 CICU 2	1	8	6.4	166.4
Telephone room	1	24	9.6	249.6
OPD area				
ECG room	1	10	5.3	138.6
Cath lab report room	1	8	2.1	55.4
Ophthalmology OPD 1	1	8	2.1	55.4
Ophthalmology OPD 2	1	8	3.2	83.2
ENT OPD classroom	1	8	3.2	83.2
ENT machine OPD	1	8	4.2	110.9
Dermatology OPD 1	1	8	4.2	110.9
Dermatology OPD 2	2	8	6.4	166.4
VIP ICU bldg.				
VIP ICU - Waiting area	1	2	1.0	27.7
VIP ICU 2	3	2	2.4	62.4

Area	No. of ACs	Working time (Hrs./day)	Power consumed (kWh/day)	Energy usage per month (kWh)
Hostels and Guest House				
Hostel no 6	15	5	20	520
Guest house	12	1	0.69	110.8
Hostel no 1	4	12	11.2	582.4
IHR room 23	1	10	5.3	138.6
IHR room 9	1	10	2.6	69.3
NRI hostel	22	12	70.4	1830.4
Extension bldg.	33	12	158.4	4118.4
New international hostel	97	12	1396.8	36316.8
Jr. Boy's hostel	2	12	12.8	332.8
Sr. Boy's hostel	6	12	38.4	998.4
Administration bldg. (medical bldg.)				
Administration office 1	1	2	1.0	27.7
Administration office 2	1	2	0.5	13.8
Medical Director office AC 1	1	8	4.2	110.9
Medical Director office AC 2	1	0	0	0
Meeting hall	2	3	3.2	83.2
PA TO Medical Director office	1	8	4.2	110.9
Administration office 3	1	8	2.1	55.4
Administration office 4	1	8	4.2	110.9
1 st floor administration office reception	1	8	4.2	110.9
Administration office 5	1	8	4.2	110.9
Administration office 6	1	8	4.2	110.93
Administration office 7	2	12	12.8	332.8
Meeting hall	2	8	6.4	166.4
Administration office 8	1	8	3.2	83.2
Administrative Office9	1	5	1.3	34.6
University bldg.				
Finance Officer	1	10	4	104
Server room	1	24	6.4	166.4
Registrar office	1	10	5.3	138.6
Anti-chamber 1	1	5	1.3	34.6
AR – Academics	1	8	2.1	55.4
Photocopy room	1	8	2.1	55.4
Exam hall	2	5	4	104
Anti-chamber 2	1	8	2.1	55.5
Chancellor office	3	4	6.4	166.4
Administration office 15	1	8	4.3	110.9
Anti-chamber 3	1	8	2.1	55.5
COE Office	1	8	3.2	83.2

Area	No. of ACs	Working time (Hrs./day)	Power consumed (kWh/day)	Energy usage per month (kWh)
AR – Academics	1	8	3.2	83.2
Anti-chamber 4	1	5	1.3	34.7
Administration office 10	1	8	4.3	110.9
Administration office 11	1	8	5.3	138.7
Administration office 12	1	4	2.1	55.5
Administration office 13	1	8	3.2	83.2
VC office	1	8	4.3	110.9
Meeting hall 1	1	8	4.3	110.9
Meeting hall 2	2	8	8.5	221.9
Exam hall	2	8	38.4	998.4
Administration office 14	2	8	38.4	998.4
Conference hall	4	4	38.4	998.4
Chairman's office	2	4	19.2	499.2
PA to chairman office	2	8	38.4	998.4
Meeting hall 3	2	0.1	0.4	10.4
Printer room	1	3	3.6	93.6
Central Medical Store bldg.				
CM Store (HoD cabin)	1	8	4.3	110.9
CM Store (Office)	1	8	4.3	110.9
PowerHouse bldg.				
Power House HoD room	1	0	0.0	0.0
Power House – EMS	1	5	2.0	52.0
AR Office area				
AR – Estate and Security	1	8	4.3	110.9
ATM	1	24	9.6	249.6
Medical college				
Annexure bldg. lecture hall	1	4	2.1	55.5
Annexure bldg. N1 hall	6	4	9.6	249.6
Research lab Microbiology	1	24	9.6	249.6
Lab	1	8	3.2	83.2
NABL lab	2	24	25.6	665.6
Academics office	1	8	2.1	55.5
Animal lab	2	8	8.5	221.9
Dean's office	1	8	3.2	83.2
AR – Administration	1	8	2.1	55.5
Virology	1	8	4.3	110.9
Central physiology	1	8	4.3	110.9
Research lab	1	8	4.3	110.9
MET hall	4	8	12.8	332.8
ELECTO physiology	1	8	3.2	83.2

Area	No. of ACs	Working time (Hrs./day)	Power consumed (kWh/day)	Energy usage per month (kWh)
EEG	1	8	4.3	110.9
HSP LAB	1	8	4.3	110.9
S1 hall	8	2	8.5	221.9
S2 hall	2	2	8.0	208.0
Molecular lab	2	4	25.6	665.6
Annexure building – Jupiter hall	9	1	21.6	561.6
Annexure building hall 02	4	2	19.2	499.2
Annexure building hall 03	4	2	19.2	499.2
Pharmacy College			0.0	0.0
Media room	2	24	19.2	499.2
HoD room	1	24	6.4	166.4
IT room	1	24	6.4	166.4
Counselling lab	3	4	8.0	208.0
Computer lab 1	1	4	2.1	55.5
Computer lab 2	1	4	2.1	55.5
OBGY lab	3	8	16.0	416.0
Library bldg.			0.0	0.0
Library	5	15	40.0	1040.0
Library	2	15	12.0	312.0
Basement	2	15	20.0	520.0
IT lab	3	8	9.6	249.6
PG library	4	12	25.6	665.6
Auditorium	6	2	6.4	166.4
Auditorium	8	2	10.7	277.3
Reading room	1	2	17.6	457.6
Dental college bldg.				
Dean's office	1	8	4.3	110.9
Dean's office waiting area	1	8	2.1	55.5
Meeting hall	1	8	4.3	110.9
Dental lab	1	8	4.3	110.9
Administrative office	1	8	3.2	83.2
New gym	1	6	28.8	748.8
Museum	1	0.1	1.6	41.6
Total energy usage per month (kWh)				154052.99

Table 8.0: Energy usage by electrical equipment:

Dept.	Area	No. of EQ	Power (kW)	Working Time (Hrs./day)	Energy Usage per Month (kWh)
Compressor	Casualty ICU	1	2.2	8	528
	KH ICU	1	2.2	8	528
	Ward no 21-28	1	7.5	8	1800
	Operation theatre	1	2.2	8	528
	C.V.T.S.	1	2.2	8	528
	C.V.T.S.	1	2.2	8	528
	Dental college	1	7.5	8	1800
	Dental college	1	2.2	8	528
	Transport	1	2.2	8	528
	Laundry	1	2.2	8	528
	Laundry	1	2.2	8	528
	C.S.S.D.	1	2.2	8	528
Autoclave	C.S.S.D. no 1	1	18	8	4320
	C.S.S.D. no 2	1	18	8	4320
	C.S.S.D. no 3	1	18	8	4320
	C.S.S.D. no 4	1	6	8	1440
	C.S.S.D. no 5	1	6	8	1440
	C.V.T.S.	1	6	8	1440
	Cath lab	1	18	8	4320
	KH ICU	1	18	8	4320
Pump WTP	Raw water pump	2	7.5	8	3600
	Dosing mixer	1	0.55	8	132
	Polymer dosing mixer	1	0.55	8	132
	Sludge transfer pump	2	0.75	8	360
	Filter feed pump	2	11	8	5280
	Air blower	1	3.7	8	888
	Brine tank mixer	1	1.1	8	264
	Flash Tank mixer	1	0.75	8	180
	Flocculator	1	0.55	8	132
	Flocculator (spare)	1	1.1	8	264
	Chlorine dosing pump	2	0.025	8	12
	Alum dosing pump	2	0.025	8	12
	Poly dosing pump	2	0.025	8	12
UV Unit	1	0.025	8	6	
PUMP STP	Sewage Transfer pump	2	2.2	8	1056
	Air blower	2	11	8	5280
	Filter feed pump	2	5.5	8	2640
	Sludge pump	2	0.75	8	360
	Poly dosing mixer	1	0.55	8	132
	Poly dosing mixer(spare)	1	2.2	8	528
	Poly dosing pump	2	0.025	8	12

Dept.	Area	No. of EQ	Power (kW)	Working Time (Hrs./day)	Energy Usage per Month (kWh)
	Chlorine dosing pump	2	0.025	8	12
Total energy usage per month (kWh)					56094

Table 9.0: Energy usages by television:

Area	No. of CFL Bulbs	Power Consumed (Watts)	Power (kW)	Working Time (Hrs./day)	Energy Usage per Month (kWh)
All wards and hospital	1	40	0.04	6	7.2
Dental college	1	40	0.04	6	7.2
Nursing hostel	1	40	0.04	6	7.2
Guest house (old/new)	37	40	0.04	6	266.4
NRI hostel	4	40	0.04	6	28.8
IHR hostel (old/new)	2	40	0.04	6	14.4
Women's hostel (1 To 7)	3	40	0.04	6	21.6
All staff qtrs.	86	40	0.04	6	619.2
Total energy usage per month (kWh)					972

Table 10.0: Energy Usage of Heaters:

Area	Heater capacity	No. of heaters	Power (kWh/day)	Energy usage per month (kWh)
Ladies hostel no. 01				
A side				
Ground floor	100	1	7	210
Ground floor	50	1	7	210
First floor	50	1	7	210
Frist floor	50	1	7	210
Second floor	100	1	7	210
Second floor	100	1	7	210
Ladies hostel B side				
Ground floor	50	1	7	210
Ground floor	100	1	7	210
First floor	100	1	7	210
First floor	100	1	7	210
Second floor	50	1	7	210
Second floor	100	1	7	210
New hostel	300	1	42	1260
New hostel	300	1	42	1260
New hostel	300	1	42	1260
Sr. Boys hostel	50	6	24	720
Sr. Boys hostel – Rector room	15	1	4	120
Jr. Boys hostel	100	10	70	2100
GNM hostel no 2				
Ground floor	50	1	4	120

Area	Heater capacity	No. of heaters	Power (kWh/day)	Energy usage per month (kWh)
Ground floor	35	1	4	120
First floor	35	1	4	120
First floor	50	1	4	120
Second floor	50	1	4	120
Second floor	10	1	6	180
BDS hostel no 3				
Ground floor	35	1	4	120
Ground floor	35	1	4	120
Ground floor	100	1	6	180
First floor	50	1	4	120
First floor	50	1	4	120
Second floor	35	1	4	120
Second floor	50	1	4	120
Third floor	35	1	4	120
Third floor	50	1	4	120
Fourth floor	35	1	4	120
Fourth floor	50	1	4	120
Hostel no 4				
Ground floor	35	1	6	180
Ground floor	15	1	4	120
First floor	50	1	4	120
First floor	50	1	4	120
Second floor	50	1	4	120
Second floor	50	1	4	120
Third floor	50	1	4	120
Third floor	50	1	4	120
Hostel no 5				
Ground floor	50	1	4	120
Mess	35	1	1.3	40
First floor	50	1	4	120
First floor	35	1	4	120
First floor	15	1	0.6	20
Second floor	50	1	4	120
Second floor	50	1	4	120
Third floor	50	1	4	120
Third floor	50	1	4	120
Fourth floor	50	1	4	120
Fourth floor	50	1	4	120
Hostel no 6				
Ground floor	50	1	3	90
Ground floor	10	1	1	30
Ground floor	10	1	1	30
First floor	10	1	5	150
First floor	15	1	0.5	15

Area	Heater capacity	No. of heaters	Power (kWh/day)	Energy usage per month (kWh)
First floor	15	1	0.5	15
First floor	10	1	0.5	15
First floor	10	1	0.5	15
First floor	10	1	6	180
First floor	50	1	6	180
First floor	50	1	6	180
Second floor	10	1	0	0
Second floor	10	1	0	0
Second floor	10	1	0	0
Second floor	10	1	0	0
Com. bath room	50	1	6	180
Com. bath room	50	1	6	180
Third floor	10	1	0	0
Third floor	10	1	0	0
Third floor	10	1	0	0
Third floor	10	1	0	0
Com. Bath room	50	1	6	180
Com. Bath room	50	1	6	180
Fourth floor	10	1	2	60
Fourth floor	10	1	0.5	15
Fourth floor	10	1	0.5	15
Fourth floor	10	1	0.5	15
Fourth floor	50	1	5	150
Fourth floor	50	1	5	150
I. H. R. hostel new bldg.				
Ground floor	50	1	4	120
Ground floor	50	1	4	120
First floor	50	1	4	120
First floor	50	1	4	120
First floor	50	1	4	120
Second floor	50	1	4	120
Second floor	50	1	4	120
Second floor	50	1	4	120
Third floor	50	1	4	120
Third floor	50	1	4	120
Third floor	50	1	4	120
I. H. R. hostel old building				
Ground floor	35	1	5	150
Room no. 1	6	1	1	30
Room no. 2	6	1	1	30
Room no. 3	6	1	1	30
Room no. 4	6	1	1	30
Room no. 5	6	1	1	30
Room no. 6	6	1	1	30

Area	Heater capacity	No. of heaters	Power (kWh/day)	Energy usage per month (kWh)
Room no. 7	6	1	1	30
Room no. 8	6	1	1	30
Room no. 9	6	1	1	30
Room no. 10	6	1	1	30
Room no. 11	6	1	1	30
Room no. 12	6	1	1	30
Room no. 13	6	1	1	30
Room no. 14	6	1	1	30
Room no. 15	6	1	1	30
N. R. I. hostel				
Ground floor	15	1	5	150
Room. 103	6	1	2	60
Room. 102	6	1	2	60
Room. 101	6	1	2	60
Room. 107	6	1	2	60
Room. 105	6	1	2	60
Room. 106	6	1	2	60
First floor 201	15	1	5	150
Room. 202	15	1	5	150
Room. 203	6	1	2	60
Room. 204	6	1	2	60
Room. 205	6	1	2	60
Room. 206	6	1	2	60
Room. 207	6	1	2	60
Room. 208	6	1	2	60
Room. 209	6	1	2	60
Second floor 301	6	1	2	60
Room. 302	6	1	2	60
Room. 303	6	1	2	60
Room. 304	6	1	2	60
Room. 305	6	1	2	60
Room. 306	6	1	2	60
Room. 307	6	1	2	60
Room. 308	6	1	2	60
Room. 309	6	1	2	60
Room. 310	6	1	2	60
Room. 311	6	1	2	60
Room. 312	6	1	2	60
Room. 313	6	1	2	60
Room. 314	6	1	2	60
Room. 315	6	1	2	60
Third floor 401	6	1	2	60
Room. 402	6	1	2	60
Room. 403	6	1	2	60

Area	Heater capacity	No. of heaters	Power (kWh/day)	Energy usage per month (kWh)
Room. 404	6	1	2	60
Room. 405	6	1	2	60
Room. 406	6	1	2	60
Room. 407	6	1	2	60
Room. 408	6	1	2	60
Room. 409	6	1	2	60
Room. 410	6	1	2	60
Room. 411	6	1	2	60
Room. 412	6	1	2	60
Room. 413	6	1	2	60
Room. 414	6	1	2	60
Room. 415	6	1	3	90
Sr. Boy's Hostel	50	1	4	120
Jr. Boy's Hostel	50	1	4	120
A type quarters [old]				
A 1	15	1	2	60
A 1	15	1	2	60
A 1	15	1	2	60
A 2	15	1	2	60
A 2	15	1	2	60
A 2	15	1	2	60
A 3	15	1	2	60
A 3	15	1	2	60
A 3	15	1	2	60
A 4	15	1	2	60
A 4	15	1	2	60
A 4	15	1	2	60
A 5	15	1	2	60
A 5	15	1	2	60
A 5	15	1	2	60
I. H. R. hostel (Inside rooms)				
First floor	50	1	4	120
Room no. 1	6	1	1	30
Room no. 2	6	1	1	30
Room no. 3	6	1	1	30
Room no. 4	6	1	1	30
Room no. 5	6	1	1	30
Room no. 6	6	1	1	30
Room no. 7	6	1	1	30
Room no. 8	6	1	1	30
Room no. 9	6	1	1	30
Room no. 10	6	1	1	30
Room no. 11	6	1	1	30
Room no. 12	6	1	1	30

Area	Heater capacity	No. of heaters	Power (kWh/day)	Energy usage per month (kWh)
Room no. 13	6	1	1	30
Room no. 14	6	1	1	30
Room no. 15	6	1	1	30
Room no. 16	6	1	1	30
Second floor	50	1	4	120
Room no. 17	35	1	3	90
Room no. 18	6	1	2	60
Room no. 19	6	1	2	60
Room no. 20	6	1	2	60
Room no. 21	6	1	2	60
Room no. 22	6	1	2	60
Room no. 23	6	1	2	60
Room no. 24	6	1	2	60
Room no. 25	6	1	2	60
Total energy usage per month (kWh)				22995

Table 11.0: Energy Usages by desktop computers:

Location	Department	No. of computers	Power consumed (Watts)	Power (kW)	Working time (Hrs./day)	Energy usage per month (kWh)
University	VC Office	5	100	0.1	8	120
University	Director Research	9	100	0.1	8	216
University	Registrar Office	11	100	0.1	8	264
University	Exam Section	5	100	0.1	8	120
KIMS & Hospital	Academic	4	100	0.1	8	96
University	Accounts	16	100	0.1	8	384
KIMS & Hospital	Administration office KIMS	5	100	0.1	8	120
KIMS & Hospital	Anatomy	9	100	0.1	8	216
KIMS & Hospital	Biochemistry	6	100	0.1	8	144
KIMS & Hospital	F.M.T	4	100	0.1	8	96
KIMS & Hospital	ICT	6	100	0.1	8	144
KIMS & Hospital	Library	32	100	0.1	8	768
KIMS & Hospital	Microbiology	6	100	0.1	8	144
KIMS & Hospital	NABL	3	100	0.1	8	72
KIMS & Hospital	P.&S.M.	5	100	0.1	8	120
KIMS & Hospital	Pathology	4	100	0.1	8	96
KIMS & Hospital	Pharmacology	3	100	0.1	8	72
KIMS & Hospital	Photography	4	100	0.1	8	96
KIMS & Hospital	Physiology	6	100	0.1	8	144
KIMS & Hospital	Lecture hall	4	100	0.1	8	96
KIMS & Hospital	Genetic lab	2	100	0.1	8	48
KIMS & Hospital	Hostels	4	100	0.1	8	96
KIMS & Hospital	Accounts KH	12	100	0.1	8	288
KIMS & Hospital	Admission	8	100	0.1	8	192
KIMS & Hospital	Anaesthesia	1	100	0.1	8	24

Location	Department	No. of computers	Power consumed (Watts)	Power (kW)	Working time (Hrs./day)	Energy usage per month (kWh)
KIMS & Hospital	Biomedical	1	100	0.1	8	24
KIMS & Hospital	Blood Bank	5	100	0.1	8	120
KIMS & Hospital	Civil	2	100	0.1	8	48
KIMS & Hospital	CM Store	9	100	0.1	8	216
KIMS & Hospital	Dermatology OPD	1	100	0.1	8	24
KIMS & Hospital	Dietician OPD	1	100	0.1	8	24
KIMS & Hospital	ECG	1	100	0.1	8	24
KIMS & Hospital	Electric	2	100	0.1	8	48
KIMS & Hospital	House Keeping	1	100	0.1	8	24
KIMS & Hospital	Incinerator	1	100	0.1	8	24
KIMS & Hospital	HR Office	2	100	0.1	8	48
KIMS & Hospital	MD Office	3	100	0.1	8	72
KIMS & Hospital	Medicine OPD	3	100	0.1	8	72
KIMS & Hospital	Medical records	4	100	0.1	8	96
KIMS & Hospital	MSW	1	100	0.1	8	24
KIMS & Hospital	NABH Office	2	100	0.1	8	48
KIMS & Hospital	NARI OPD	2	100	0.1	8	48
KIMS & Hospital	Neuro Surgery	1	100	0.1	8	24
KIMS & Hospital	New Pharmacy	6	100	0.1	8	144
KIMS & Hospital	Night evening supervisor room	1	100	0.1	8	24
KIMS & Hospital	Nursing office	5	100	0.1	8	120
KIMS & Hospital	O.T	4	100	0.1	8	96
KIMS & Hospital	OBGy	4	100	0.1	8	96
KIMS & Hospital	Ophthalmology	2	100	0.1	8	48
KIMS & Hospital	Orthopaedic	2	100	0.1	8	48
KIMS & Hospital	Pathology KH	5	100	0.1	8	120
KIMS & Hospital	Paediatric	3	100	0.1	8	72
KIMS & Hospital	Pharmacy Sec-2	8	100	0.1	8	192
KIMS & Hospital	PRO	3	100	0.1	8	72
KIMS & Hospital	Security	4	100	0.1	8	96
KIMS & Hospital	Surgery	3	100	0.1	8	72
KIMS & Hospital	Ward-Cathlab-W2	5	100	0.1	8	120
KIMS & Hospital	Wards-CVTS-W1	3	100	0.1	8	72
KIMS & Hospital	Wards (3-32)	33	100	0.1	8	792
KIMS & Hospital	X-Ray	14	100	0.1	8	336
Dental college	Dean	1	100	0.1	8	24
Dental college	Office	6	100	0.1	8	144
Dental college	OPD	1	100	0.1	8	24
Dental college	Oral Pathology	1	100	0.1	8	24
Dental college	Prosthodontics	2	100	0.1	8	48
Dental college	Conservative	4	100	0.1	8	96
Dental college	OMDR	3	100	0.1	8	72
Dental college	Oral Surgery	3	100	0.1	8	72
Dental college	PHD	2	100	0.1	8	48

Location	Department	No. of computers	Power consumed (Watts)	Power (kW)	Working time (Hrs./day)	Energy usage per month (kWh)
Dental college	Periodontics	2	100	0.1	8	48
Dental college	Orthodontics	1	100	0.1	8	24
Dental college	Pedodontics	2	100	0.1	8	48
Dental college	Store	2	100	0.1	8	48
Dental college	Library	3	100	0.1	8	72
Dental college	NAAC office	1	100	0.1	8	24
Dental college	Server room	2	100	0.1	8	48
Dental college	Cashier room	1	100	0.1	8	24
Dental college	Computer lab	10	100	0.1	8	240
Nursing college	Principal	1	100	0.1	8	24
Nursing college	Office + V.P	7	100	0.1	8	168
Nursing college	Med Surgical	1	100	0.1	8	24
Nursing college	OBGy	1	100	0.1	8	24
Nursing college	Psychiatry	1	100	0.1	8	24
Nursing college	Paediatric	1	100	0.1	8	24
Nursing college	Library	2	100	0.1	8	48
Nursing college	Computer lab	15	100	0.1	8	360
Nursing college	Education	1	100	0.1	8	24
Nursing college	Community health	1	100	0.1	8	24
Nursing college	Lecture hall		100	0.1	8	0
Physiotherapy college	Principal	1	100	0.1	8	24
Physiotherapy college	Office	2	100	0.1	8	48
Physiotherapy college	NAAC Room	2	100	0.1	8	48
Physiotherapy college	Library	5	100	0.1	8	120
Physiotherapy college	OPD Counter	2	100	0.1	8	48
Physiotherapy college	Orthotic/Pros	2	100	0.1	8	48
Physiotherapy college	Lecturer hall		100	0.1	8	0
Pharmacy college	Principal	1	100	0.1	8	24
Pharmacy college	Office	1	100	0.1	8	24
Pharmacy college	Computer lab	21	100	0.1	8	504
Pharmacy college	Library	1	100	0.1	8	24
Pharmacy college	Staff room	1	100	0.1	8	24
Biotech college bldg.	Principal	1	100	0.1	8	24
Biotech college bldg.	Office	1	100	0.1	8	24
Biotech college bldg.	Lab	17	100	0.1	8	408
Total energy usage per month (KWh)						10968

4.4 WASTE MANAGEMENT

Table 12.0: Waste Generated in the Premises:

Type of waste	Per day
Biomedical waste	248 Kg
Plastic waste	96 Kg
Solid waste	533 Kg
Laboratory waste	10 Kg
Waste water	302 m ³
Glass waste	32 Kg

- E-waste generated in the campus is stored separately as per rules and pollution control board standards. It is disposed through sale to the authorised E-waste recycler.
- To treat sewage and effluent generated in the campus KIMSDU have separate treatment plants of capacity 2 x 500 m³/day and 100 m³/day respectively. The total treated water is recycled 100%
- 3 R principle sound practices are implemented.
- Use of plastic in the premises is banned.
- Non hazardous solid waste is handled and disposed through sound practices.

Table 13.0: Area wise Waste generation:

Type of waste	Areas	Wt.
Biodegradable	Cafeteria	11 Kg
	Hostel No.4	12 Kg
	Nursing hostel	17 Kg
	Hospital canteen	23 Kg
	Hospital wards	9 Kg
Non-biodegradable	Cafeteria	5 Kg
	IHR hostel	17 Kg
	NRI hostel	19 Kg
	Guest house	6 Kg
	Hostel No.4	6 Kg
	Hostel No.5	7 Kg
	BDS hostel	8 Kg
	Girl's hostel	9 Kg
	VenutaiChavan hostel	9 Kg
	Nursing hostel	8 Kg
	Nursing college	37 Kg
	Sarita bazaar	15 Kg
	Hospital canteen	15 Kg
	Hospital wards	393 Kg
Biomedical waste	Hospital	248 Kg
	Lab	10 Kg
Hazardous waste	Dental model	1.75 Kg
	ETP Sludge	1.10 Kg
Canteen waste	Dry solid waste	16 Kg
	Food waste	23 Kg

Table 14.0: E-Waste generated (one month data):

Sr. No.	Specification	Numbers
1	Geyser Coil	28
2	Choke	14
3	Loose wire	21
4	Exhaust fan body (PUC)	22
5	MCB	11
6	40 Watt tube	35
7	36 Watt tube	30
8	CFL Lamp	15
9	LED Lamp	20
10	PUC Patti	162
	Total	358

Sample/Evident collection Water Management :

Sample 1 : Biodegradable solid waste is collected, segregated & stored in a scientific manner. It is further treated in house to produce manure. KIMSDU has installed sufficient capacity organic waste convertor/waste composter machine. Averagely 1.5 T - 2.0T of manure generates annually which is utilised for the trees planted in the campus.

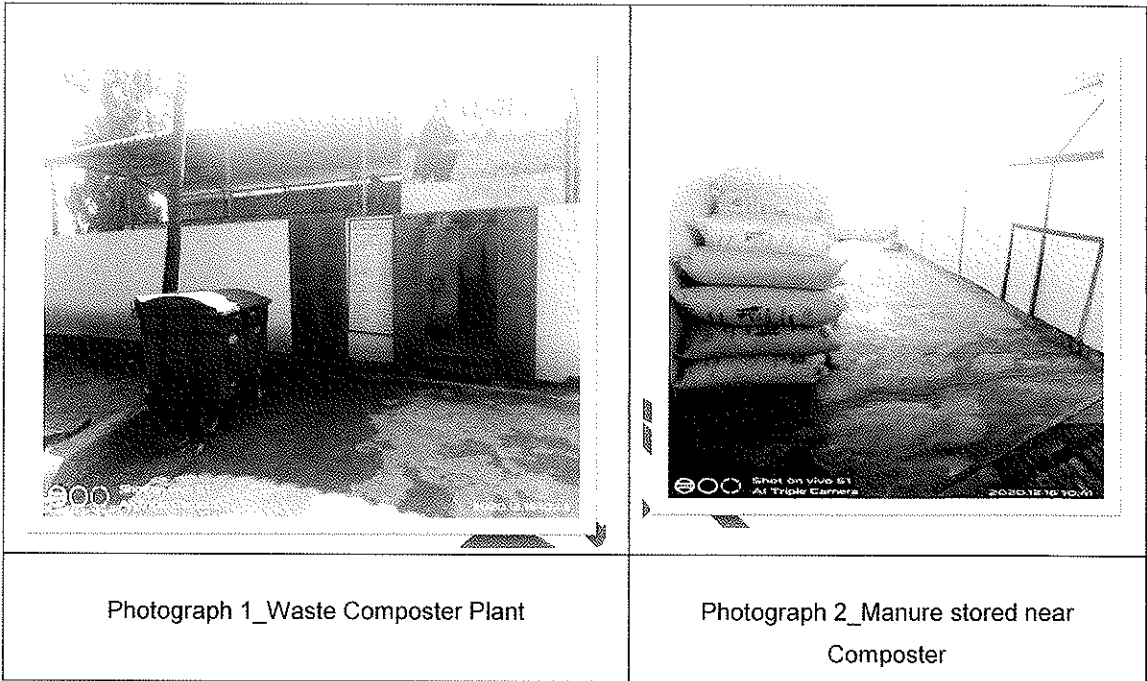

Sample 2 : E-waste generated in the campus is stored separately as per E waste rules & Norms of pollution control board standards and is sent to authorised E-waste recycler. Site visit conducted and observed to be satisfactorily.

Sample 3 : To treat sewage and effluent generated in the campus KIMSDU have separate treatment plants of capacity 2 x 500 m3/day and 100 m3/day respectively. Total 250 m3/day treated sewage water is reused for gardening purpose. Site visit conducted and observed to be satisfactorily.

4.5 GREEN CAMPUS

The Green campus drive is an initiative of the KIMSDU to protect the environment. The KIMSDU has been declared as a 'No Plastic' zone'. The campus protects age old trees in addition to several new trees and plants planted. The campus is lush green with gardens, lawns, flowers and plants wherever there is open space.

- Total number of plant species identified 65 Nos.
- Total number of plants 3096 Nos.
- Tree cover of the campus 89784 Sq. Mtrs.
- Free space in the campus 129393 Sq. Mtrs.
- Hospital campus area 233757 Sq. Mtrs.

Table 15.0: Type and number of trees planted in the premises

Sr. No.	Name of the Tree	No. of Trees Planted
1	Subabul	273
2	Bougainvillea	275
3	Coconut	242
4	Teak	160
5	Mango	102
6	Palm	611
7	Kashid	79
8	Sandalwood	62
9	Ficus	162
10	Yellow Gulmohar	58
11	Nimb	57
12	Silver Oak	134
13	Plumeria	64
14	Neelmohar	50
15	Custard Apple	47
16	Sesam	45
17	Saras	65
18	Giripushpa	31
19	Ashoka	27
20	Ramphal	27
21	Booc	31
22	Bottle Brush	32
23	Gulmohar	21
24	Indian Almonds	15
25	Audumbar	15

Sr. No.	Name of the Tree	No. of Trees Planted
26	Thuja	18
27	Guava	42
28	Cherry	19
29	Chiku	13
30	Suru	13
31	Indian Gooseberry	9
32	Rubber	8
33	Nilgiri	8
34	Kanchan	8
35	Jambul	8
36	Tamarind	22
37	Non-native tamarind	18
38	Drumsticks	12
39	Banyan	4
40	Berry	5
41	Crotan	5
42	Rentry	5
43	Pomogranate	4
44	Karanji	4
45	Karaja	23
46	Fushcia	4
47	Jackfruit	4
48	Parijaat	3
49	Tabebuya	2
50	Rudraksha	3
51	Akrol	2
52	Mehendi	2
53	Kawat	2
54	Christmas tree	1
55	Anant	2
56	Cyprus	2
57	Bakui	2
58	Bel	2
59	Saragi	16
60	Bhokar	1
61	Baldoli	1
62	Taman	1
63	Yellow Bamboo	100
64	RaktaChandan	2
65	Betelnut	11
	Total No of Trees	3096

4.6 ROUTINE GREEN PRACTICES:

A. Swachha Bharat Abhiyan :

To support the cleanliness campaign started by Government of India KIMSDU regularly arranges campus cleaning program.

Team Members :

Sr. No.	Participant	Designation
1.	Mr. Ganesh S. Patole	Environmental Supervisor
2.	Mr. Aananda T. Suryagandh	Housekeeping Assistant
3.	Mr. Dnyandev P. Hogade	Housekeeping Attendant
4.	Mr. Kismat I. Modak	Housekeeping Assistant
5.	Mr. Balu B. Yedage	Housekeeping Attendant
6.	Mr. Kailash P. Lakhe	Housekeeping Attendant
7.	Mr. Vijay A. Mate	Housekeeping Assistant
8.	Mr. Avinash M. Bansode	Housekeeping Assistant
9.	Mr. Bhikaji A. Kamble	Housekeeping Assistant
10.	Mr. Vivek S. Kapurkar	Housekeeping Assistant



Photograph 3_Cleaning Drive



Photograph 4_Cleaning Drive

B. Plantation :

Since year 2015 KIMSDU is actively doing plantation. Within 05 years it is evident that they planted more than 1000 trees i.e. 1174 nos. Now the total count of the premises is 3096. It is very appreciable w. r. t. green campus drive by providing such a huge green coverage.

Year	No. of trees planted per year
2015	71
2016	286
2017	279
2018	247
2019	281
2020	10
TOTAL	1174

C. World Environment Day :

World Environment Day (WED) is observed worldwide on 5th June. KIMSDU also celebrates WED with participation of staff and stakeholders. Various programs are organised on the day such as seminars, plantations, cycle rally etc.



Photograph 5_WED Appreciation of participants



Photograph 6_WED Participants

4.7 CARBON FOOTPRINT

The carbon footprint data is important to estimate and minimise the carbon dioxide (CO₂) emission in the atmosphere. Carbon dioxide is one of the main green house gases among others which are responsible for damaging ozone layer of the earth.

The summary of fossil fuel usage observed in the campus as follows:

Number of persons using cycles	30
Number of persons using cars	176
Number of persons uses two wheelers	940
Number of persons using other transportations	1348
Number of visitors per day	2000
Average distance travelled by stake holders	3 Kms/Day
Expenditure for transportation per person per day	11/-

Fossil Fuel Calculations :

Petrol used by two wheelers/day : 470 L (Per person to and fro 40 kms =1L)

Fuel used by four wheelers(176 Persons): 176 L (Per person to and fro 20kms = 1L)

Fuel for persons (total 1348 persons)

travelling by common transportation : 108 L (4 L/person x 50 persons)

Total fossil fuel use is : **754 L / day**

Total fuel cost per day for transportation : Rs. 60,320/- (754 L x @ Rs 80/-)

Burning of fossil fuels is the main source and cause of carbon dioxide release to the atmosphere. Reducing the fuel consumption will lead to reduce carbon dioxide emissions in the atmosphere. Use of fossil fuels has to be reduced for the sake of community health. The above target areas particular to the hospital was evaluated through questionnaire circulated among the key staff for data collection and the personal interview. The analysis data and approach of people found & observed very positively.

5 CONCLUSIONS AND RECOMMENDATIONS

There is always scope for the further improvement w. r. t. to its approach and aspects with changing circumstances. Green Audit is a tool utilised to know/find out the KIMSDU strengths and weakness of environmental sustainable practices. It also considered through the professional approach towards way to responsible utilising of financials to handle economic, social responsibility and environmental resources. Green Audit initiative taken by the institute and is a way of identifying, evaluating and managing environmental risks. No approach or sound practices are 100 % full proof.

KIMSDU is operating and acting environmentally responsible manner by considering and adopting abatement practices for all environmental impacts of most of its actions and makes a continual improvement.

KIMSDU has a Environmental policy and found committed towards compliance of government laws, regulations and other policy mechanisms concerning environmental issues.

KIMSDU considered and worked out efficiently on all the probable and potential impactful issues present in the premises with related to all the activities which include air & water pollution, waste management, maintenance of biodiversity, the management of natural resources & ecosystem in campus.

Organisation has utilising all the resources taken from environment in economic way with social due care. Water management and conservation is in good condition. The various sources of water are river, bore wells and some part through Malakapur Municipal Council supply. It is observed that adequate water meters are installed in the premises to track the water quantities utilised. The sewage wastewater after treatment is used for gardening (maximum quantity) purpose and some portion is recycled for WC flushing purpose. There is no wastage of water observed in the premises. All the taps/ faucets are well maintained.

KIMSDU have installed rainwater harvesting in the campus which is used for recharging the few bore wells in the premises. It is estimated that around 10 lakh litres of water can be saved through rain water harvesting.

Waste Collection, segregation and treatment is well practiced in the premises. Biodegradable waste is collected separately and sent to waste composter of capacity 1000 Kg/day. It can process waste upto 700 Kg at a time. Manure generated from composter is used for gardening purpose. KIMSDU has a biogas plant. Non biodegradable municipal waste is regularly collected by authorised agency. Biomedical waste is collected and disposed of on the daily basis. Biomedical waste is sent to Common Biomedical Waste Disposal Facility operated by Karad Hospital Association. E-waste generated in the premises are stored separately and disposed of through

authorised recycler. Colour coded waste segregation bins are facilitated in the premises and followed strictly.

KIMSDU is very conscious about energy management. Maximum bulbs and tube lights are of energy saving type (LED and CFL). To cater the energy expansion need KIMSDU have installed 500 kW and 400 kW solar plants for energy generation. Due to this solar project KIMSDU is saving 108000 units per month.

Area For improvements

- There are no waterless urinals available at present in the premises, so management can think of provision of same to reduce down the water usage in the future.
- Carbon footprints can be improved further through some process changes like issue the guidelines for car pull or can execute the odd and even car number car driving on alternate days, For Common transportation KIMSDU can run e-vehicles for pick-up and drop of staff members. This will reduce the fossil fuel consumption drastically.
- KIMSDU can promote use of cycles within the campus.

Conclusion

Green audit carried out at KIMSDU facility are found to be satisfactory w. r. t. requirements of rules and regulations enforced by authorities, organisational set policies & procedures, documented systems, objectives taken time to time. It is very difficult to see each and every aspect on site but with all observation, site survey and sampling carried out for fact finding, we found the essence of green audit satisfactorily for all the environmental aspects, objectives set. Organisation's environmental performance found accountable, monitored, analyzed for its results for continual improvement.

6 ACKNOWLEDGEMENTS

Green Scientific Development (I) Pvt. Ltd. is thankful to the Management of the Krishna Institute of Medical Sciences, "Deemed To Be University", Karad for entrusting processes of Green auditing with us. We thank all the participants of the auditing team especially engineering, maintenance and environmental staff who took all the efforts along with us to gather data and participated in throughout the survey for facts findings. We also thank the office staff who helped us during the document verification.

7 ANNEXURE: CAMPUS LAYOUT

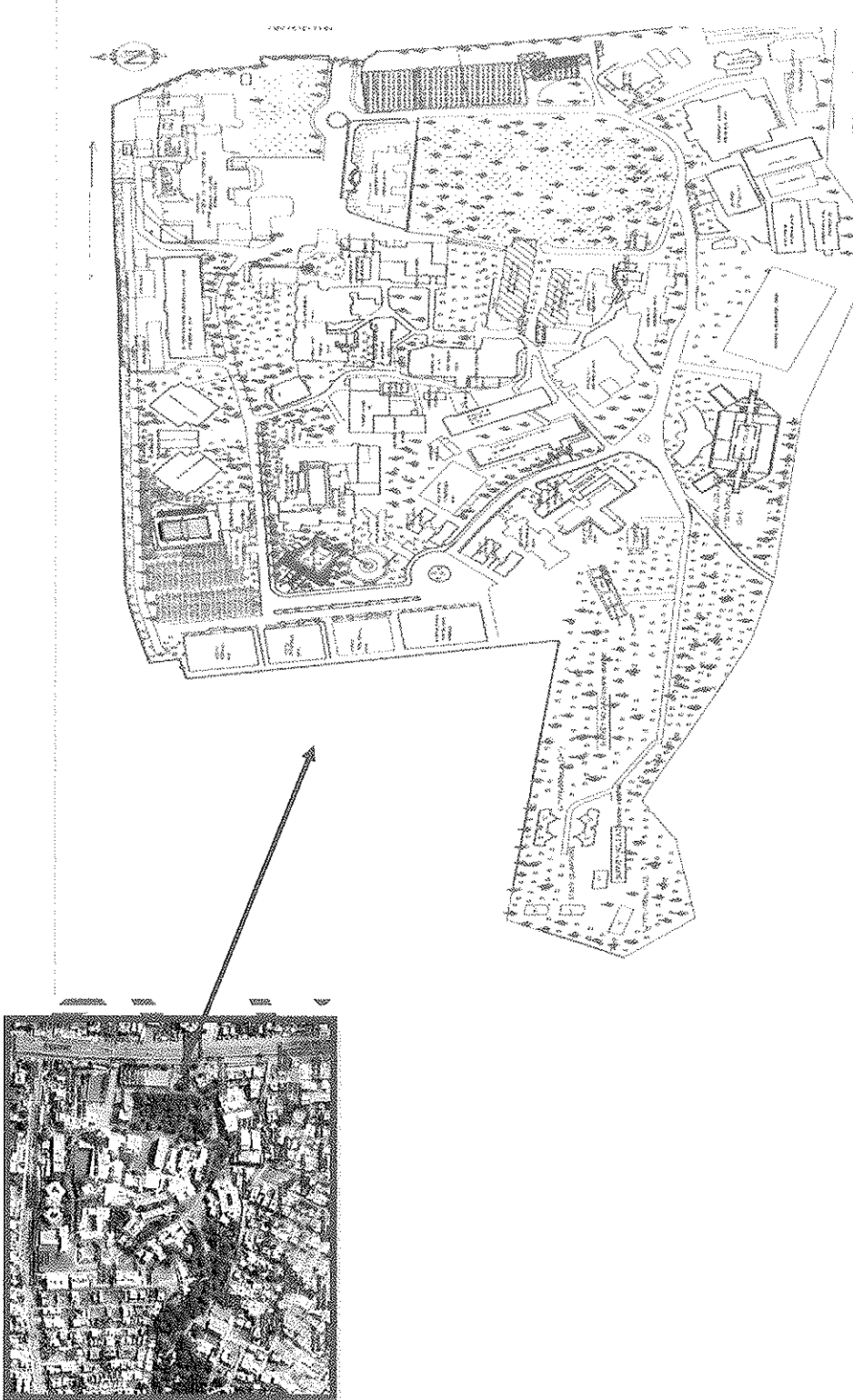

8 Photo Gallery (KIMSDU CAMPUS)

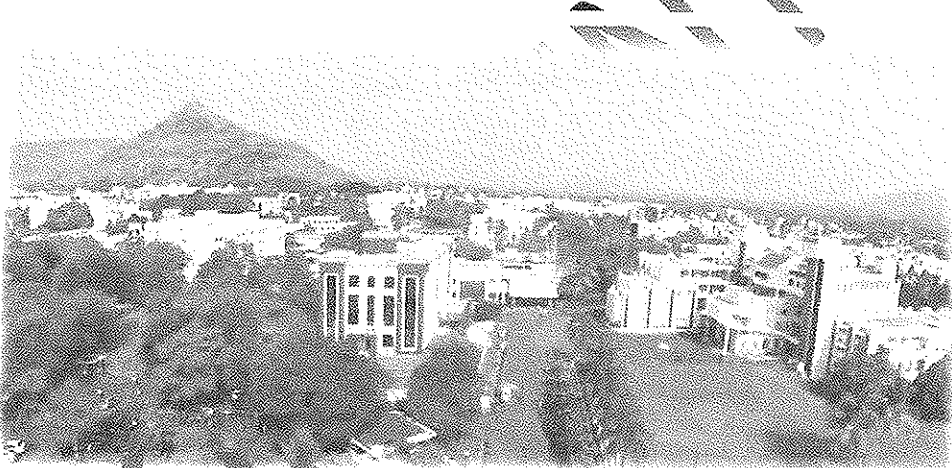

REGISTRAR
Krishna Institute of Medical Sciences
"Deemed To Be University", Karad



ENVIRONMENTAL AUDIT REPORT - 2019

Auditee

*Krishna Institute Of Medical Sciences,
"Deemed To Be University"
Malakapur, Tal: Karad, Dist: Satara, Maharashtra*

Auditor

*Green Scientific Development (I) Pvt. Ltd.
4/A Wing, Bldg No. 23, Tulsi C.H.S. Ltd,
Subhash Nagar, Chembur, Mumbai 400071
Mobile 9820239183*

September 27, 2019

REGISTRAR
Krishna Institute of Medical Sciences
"Deemed To Be University", Karad

Table of Contents

1.0	ENVIRONMENTAL AUDIT COMPLETION CERTIFICATE	4
2.0	ENVIRONMENTAL AUDIT COMMITTEE & AUDIT PROGRAM	5
2.1	ENVIRONMENTAL AUDIT COMMITTEE	5
2.2	ENVIRONMENTAL AUDIT SCHEDULE	5
3.0	INTRODUCTION	6
3.1	VISION	7
3.2	MISSION	7
3.3	THE BEGINNING	7
3.4	ABOUT HOSPITAL	8
3.4.1	<i>Clinical Departments</i>	8
3.4.2	<i>Super Specialty Services</i>	9
3.4.3	<i>Clinical Information</i>	9
3.4.4	<i>Facility Departments</i>	10
3.4.5	<i>Emergency Services (Casualty)</i>	10
3.4.6	<i>Admission Office</i>	10
3.4.7	<i>Out Patient Services</i>	10
3.4.8	<i>Blood bank</i>	11
3.4.9	<i>Diagnostics</i>	11
3.4.10	<i>In Patient Services</i>	11
3.4.11	<i>Intensive Care Units</i>	11
3.4.12	<i>ICU Details</i>	12
3.4.13	<i>Operation Theatres</i>	12
3.4.14	<i>Super Specialty Services</i>	12
3.4.15	<i>State of the Art Technology</i>	13
3.4.16	<i>Leading the Way</i>	13
3.4.17	<i>Ancillary Therapy</i>	13
3.4.18	<i>Charity Schemes</i>	13
3.4.19	<i>National and International Collaborations</i>	14
3.4.20	<i>Service Collaborations</i>	14
3.4.21	<i>Outreach Activities</i>	14
3.5	OBJECTIVES OF STUDY	15
3.6	METHODOLOGY	15
4.0	ENVIRONMENTAL ASPECTS	16
4.1	PRESENT INFRASTRUCTURE & AREA	16

4.2	WATER ENVIRONMENT	19
4.2.1	<i>Water Management.....</i>	21
4.2.2	<i>Storm Water & Rain Water Harvesting</i>	24
4.3	AIR ENVIRONMENT	26
4.3.1	<i>Ambient Air Quality</i>	27
4.3.2	<i>Indoor Air Quality</i>	28
4.4	WASTE GENERATION & MANAGEMENT.....	31
4.4.1	<i>Biomedical Waste</i>	31
4.4.2	<i>E- Waste.....</i>	34
4.4.3	<i>Municipal Solid and Other Wastes Management at KIMSDU Campus</i>	35
4.5	ENERGY ENVIRONMENT.....	36
4.6	SAFETY AND HEALTH ENVIRONMENT.....	38
4.6.1	<i>Fire Safety.....</i>	38
4.6.2	<i>Patient and Staff Safety</i>	39
4.6.3	<i>Radiation Safety.....</i>	41
4.6.4	<i>Infection Control.....</i>	42
4.7	NOISE / AESTHETICS / SOCIAL ENVIRONMENT.....	43
5.0	CONCLUSION.....	44
5.1.1	<i>List of the Area for improvement (AFI).....</i>	45
5.1.2	<i>Positive (+ Ve) Observation</i>	45

1.0 Environmental Audit Completion Certificate

Name of the Installation	Krishna Institute Of Medical Sciences, "Deemed To Be University", Karad, Satara - 415539
Details of Facility Audited	All the facilities under KIMSDU at Karad
Date of Environment Audit	27 September 2019
Name of Lead Auditor	Mr. Kiran Shinde - EMS Lead Auditor
Name of Co-Auditor	Mr. Mahesh Chhatre - Environment Expert
Name of Auditing Company	Green Scientific Development (I) Pvt. Ltd. 4/A Wing, Bldg No. 23, Tulsi C.H.S. Ltd, Subhash Nagar, Chembur, Mumbai – 400071

Signature of Auditor :

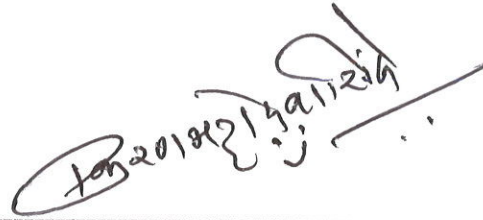

Lead Auditor :

Mr. Kiran Shinde

Certification No :

ISO 14001:2015 _ 35142852 02

Delegate No 168345

Dated 15.04.2019

Stamp of Company :



2.0 Environmental Audit Committee & Audit Program

Environmental Audit Date : 27 September 2019

2.1 ENVIRONMENTAL AUDIT COMMITTEE

Table 1.0: List of The Audit Committee

Auditors - External Members			
1	Mr. Kiran Shinde	Lead Auditor	Lead Auditor
2	Mr. Mahesh Chhatre	Co-Auditor	Environment Expert
Auditee - In-house Members			
1	Mr. S. A. Mashalkar	Chair Person	Assistant Registrar - Estate & Security
2	Mr. Tushar Kadam	MR	Office Superintendent
3	Mr. Ganesh Patole	Member	Environmental Supervisor
4	Mr. D. S. Kashid	Member	Civil Supervisor
5	Mr. S. Y. Kirdak	Member	HOD- Garden Dept.
6	Mr. Y. G. Kulkarni	Member	HOD - Power House Dept.

2.2 ENVIRONMENTAL AUDIT SCHEDULE

Table 2.0: Audit Schedule With Time and Location

Heads	From	To	Location
Opening Meeting	9.00	9.30	With Management Team & Auditee
Site Visit	10.00	12.00	Departments
Lunch Hr	12.00	13.00	In House
Site Visit	13.00	17.00	Campus and Utilities
Closing Meeting	17.30	18.30	With Management Team & Auditee

3.0 INTRODUCTION

Krishna Institute of Medical Sciences “Deemed To Be University”, Karad is located in Western Maharashtra, India against the background of mountains and valleys. The green, eco-friendly campus is spread over 57 acres and is well connected by rail, road & air.

The University is accredited by NAAC 'A' grade and has been conferred with ISO 9001 certification. The constituent faculties of the University include Medical, Dental, Physiotherapy, Nursing, and allied sciences offering undergraduate and postgraduate courses in the respective faculties. It also runs Ph.D. programs and Post Doctoral Fellowships in various subjects.

The medical college is about 35 years old and is recognized by the Medical Council of India, Medical Council of Malaysia and is listed in the WHO's World Directory of Medical Schools. MBBS and postgraduate degree/diploma courses in clinical and basic sciences in 17 disciplines are recognized by Medical Council of India. It also admits the international students from all over the globe for undergraduate courses.

The teaching hospital is 1125 bedded multispecialty tertiary care hospital with facilities for Critical Care, Endoscopic Surgeries, Dialysis, Cardiology, Cardio-vascular-thoracic-surgery, Oncology, Urology, Neurosurgery, Plastic surgery, Oral and Maxillofacial Surgery and a recognized Renal Transplant Unit. It has fully equipped major operation theaters, minor theaters, labour rooms, blood bank accredited by NABH, radiodiagnosis and radiotherapy, computerized medical records, counselling services etc. There are separate intensive care units like Medical, Surgical, Coronary care, Pediatric, Neonatal (accredited by Neonatology Forum of India), Respiratory and Obstetrics. The neonatal ICU is recognized by Neonatology Forum of India. The radio-diagnosis department has facilities for MRI, color doppler, mammography, DSA etc. It also actively participates in national healthcare programs and various extensions and outreach community programs initiated by the Institute.

The University has been ranked 5th amongst the cleanest higher Educational Institutions in the category of 'Technical Institutions - Universities (Residential)' in the year 2018. The University has also received certificate for 'Maintaining, Promoting and Encouraging the Culture of Swachhta in Higher Education Institutions in the country'.

3.1 VISION

To emerge as a centre of excellence following an interdisciplinary, innovative and quality centric approach that encompasses best evidence based higher education and generates refutative and translational research and offers affordable health care access for the benefit of mankind.

3.2 MISSION

- Krishna Institute of Medical Sciences "Deemed To Be University" shall prepare competent and compassionate professionals with sound knowledge and excellent skill through quality education based on a competency model that inculcates scientific temper, moral and ethical values.
- It shall foster interdisciplinary research that will generate meaningful outcomes for the community and nation.
- It shall provide quality health care to the rural and needy and bring about holistic development in the adjoining rural areas.
- It shall seek collaborations with national and international institutions of repute and provide a transparent and accountable governance system.

3.3 THE BEGINNING

Krishna Hospital and Medical Research Centre, Karad had a modest beginning with 200 beds hospital in one of the remotest areas in southern Maharashtra in the year 1982. Over the span of last 3 and half decades the hospital has grown to an 1125 beds multi-specialty hospital. The hospital was accredited by NABH in the year 2016 and then reaccredited in the year 2019. The NABH accreditation has ensured that protocols are streamlined and as per internationally accepted best practices. Krishna hospital is committed to provide standard treatments and quality care. Quality care involves specialized techniques, instrumentation, infrastructure and knowledgeable and skilled professionals. In our country where primary health care still remains a priority, our aim is to bring quality health care within reach of people living in villages.

3.4 ABOUT HOSPITAL

Krishna Hospital is an institute that resonates the coming of age of medical services in India. May it be a day to day regular ailment or a concern that requires specialty services and care it can all be found here. A team of expert doctors with decades of experiences highly trained nursing and ancillary staff, latest equipment and machines handled by skilled technical staff and a strong backbone of support services has helped elevate Krishna Hospital to a premier health care institute. The hospital with a capacity of 1125 beds, 32 wards, 8 different ICUs has added a number or various capabilities over the years, however has always stayed true to its DNA of “affordable, quality medical services for all”.

3.4.1 *Clinical Departments*

- General Medicine
- General Surgery
- Transplant services
- Keratoplasty
- Anesthesiology
- Obstetrics &Gynecology
- Pediatrics
- Orthopedics
- Total Hip Replacement
- Total Knee Replacement
- Orthoscopy
- Medical Imaging Services
- Radiotherapy
- Medical oncology
- ENT
- Ophthalmology
- Psychiatry
- Pulmonology
- Dermatology
- Endoscopy
- Laparoscopy

3.4.2 *Super Specialty Services*

- Neurosurgery
- Neurology
- Plastic and Reconstructive Surgery
- Pediatric Surgery
- Genito-Urinary Surgery
- Surgical Oncology
- Nephrology
- Cardiology
- Cardio Vascular and Thoracic Surgery
- Radiotherapy
- Medical Oncology

3.4.3 *Clinical Information*

The hospital has state of the art facilities with 100 super specialty beds for Neurosurgery, Neurology, Plastic and Reconstructive surgery, Pediatric surgery, Genito-Urinary Surgery, Surgical Oncology, Nephrology, Cardiology and Cardio Vascular Thoracic Surgery. Specialized ICUs are available namely Surgical ICU, Medical ICU, High Dependency Unit, Coronary Care ICU, CVTS ICU, Neonatal ICU, Pediatric ICU, Maternal ICU and Cardiology ICU etc. which occupy different sections with a total bed capacity of 112 beds. Critical Care is a separate unit at the hospital with 24*7 availability of on-location intensives. The Emergency room is well equipped and well staff with 30 beds and a separate ICU with 6 beds. The hospital also has 40 private rooms which include 20 deluxe rooms and 20 super deluxe and suites to accommodate patients with various needs and requirements.

There are 13 ultra-modern operation theatres with laminar airflow and 4 minor operation theatres for OPD patients. Krishna hospital has been one of the pioneers in implementing quality culture in a teaching hospital with NABH accredited blood bank which has component facility and plasmapheresis unit. A well-equipped NICU with 20 beds accredited by NNFI.

3.4.4 *Facility Departments*

- Emergency services (Casualty)
- Admission office
- OPD services
- Blood bank
- Components facility
- Plasmapheresis
- Diagnostic Services
- Inpatient services
- Intensive care units
- Operation theatres
- Radio-diagnosis
- Specialty services
- State of the art technology
- Leading the way
- Ancillary therapy
- Charity schemes
- National and international collaborations
- Service collaborations
- Outreach activities

3.4.5 *Emergency Services (Casualty)*

The Casualty has 30 beds with central oxygen, suction and other resuscitative measures. 6 ICU beds in the casualty are provided for immediate medical care and after stabilization patients are transferred to respective inpatient wards. Others are discharged after preliminary treatment with instructions to attend follow-up in the OPD.

3.4.6 *Admission Office*

The admission office provides courteous service to all patients and necessary documents for registration. The patient data is collected on customized software "Lifeline" which also helps to analyze the performance of departments. Various government run schemes for patients are implemented through this office.

3.4.7 *Out Patient Services*

The outpatient department is located at the entrance of the hospital complex. Clinical examination rooms for consultants of various disciplines are provided with central facilities which includes rooms for ECG, USG, treadmill, applying and cutting plaster, injections and vaccines, blood collection and counselling. There are four minor operation theatres in the OPD complex. The Registration counter is computerized and linked to central medical records. All OPDs have space for teaching.

3.4.8 *Blood bank*

NABH accredited blood bank at Krishna Hospital offers components facility.

3.4.9 *Diagnostics*

Diagnostics is an important part of medicine and Krishna Hospital has always ensured due care toward upgradation and advancements of both clinical and diagnostics aspect of patient care. The Central Clinical Laboratory and Imaging Services with CT, MRI, Digital X-Ray and imaging intensifier, Mammography, Sonography and Colour Doppler services are provided with the assistance of latest breakthrough in technology. It also provides services like EEG, EMG, and Bera.

3.4.10 *In Patient Services*

The wards are well lighted and ventilated with special attention to prevent nosocomial infections as they contribute to loss of resources. Guidelines on safe practices, waste disposal and sanitation are introduced with a view of improving general sanitation and hygiene.

3.4.11 *Intensive Care Units*

Critical care is now recognized as a specialty. Traditional intensive care along branches of medicine, surgery, paediatrics are slowly transforming into a more integrated pattern with advancing knowledge, procedures, equipment and newer methods of treatment. However the extension of intensive care to further specialization in Coronary care (CCU), Respiratory care (RICU), Neonatal care (NICU), Burns etc. will continue and further expand to deal with any emergency. Intensive Care Units have advanced equipment, life support systems, professionals with special skills, standardized protocols resulting in improved clinical outcomes.

The Neonatal ICU at Krishna Hospital is recognized by the Neonatal Forum of India at IIB level. This 20 bedded ICU handles basic and specialty new born care.

3.4.12 ICU Details

<u>Sr.</u>	<u>Type</u>	<u>Beds</u>
1.	Casualty	06
2.	High Dependent Unit	14
3.	Coronary Care (CCU)	05
4.	Medical ICU	17
5.	Surgical ICU	16
6.	Neonatal ICU	20
7.	Ob/G ICU	04
8.	Paediatric ICU	04
9.	Cath lab ICU	08
10.	CVTS ICU	12
11.	Burns ICU	06
	Total	112

3.4.13 Operation Theatres

The OT complex consists including 13 state-of-art modular operation theatres. The complex is set up in accordance with NABH guidelines having central oxygen, nitrous and suction supplies, modern anaesthesia work stations and an attached dedicated Central Sterile Supplies Department (CSSD) with unidirectional flow. All types of general surgical, orthopaedic, ophthalmology, ENT, obstetrics & gynaecology procedures are conducted routinely. Super-specialty procedures which includes Neuro-surgery; Plastic and reconstructive surgery, Genito-urinary surgery, Paediatric surgery, Cardio-Vascular and Thoracic surgery, Cardiac procedures, Transplant surgeries etc. are also carried out.

3.4.14 Super Specialty Services

In its endeavour to provide quality medical care at reasonable cost KIMSDU has made significant progress in various super specialty services. Renowned experts with years of experience in their respective fields, dedicated pre and post-surgery care with efficient and well trained staff sets KIMSDU apart from other institutes offering similar services. KIMSDU believes in not adding years to life but also quality to life. Below are the different super specialty expertises on offer at Krishna Hospital.

- Neurosurgery
- Plastic and Reconstructive Surgery
- Genito-Urinary Surgery
- Nephrology
- Cardio Vascular and Thoracic Surgery
- Medical Oncology
- Neurology
- Paediatric Surgery
- Surgical Oncology
- Cardiology
- Radiotherapy

3.4.15 *State of the Art Technology*

The hospital has been at the forefront on implementing innovations in the field of patient care and teaching. In this endeavour the hospital has state of the art Cath-lab, CTVS unit, Cancer Care Centre with Linear Accelerator and separate facility for Chemotherapy as well as a modern Dialysis unit.

3.4.16 *Leading the Way*

As a very important tertiary care centre and a leading university in the field of medicine, the hospital also has a dedicated Eye Bank with Keratoplasty, separate Burns unit with 6 ICU beds, Central Research Lab, Clinical and Demo rooms equipped with audio-visual teaching aids and well stocked clinical instruments, clinical materials and equipment.

3.4.17 *Ancillary Therapy*

Krishna Hospital has a team of well qualified and highly efficient psychology counsellors and Medical Social Workers that assist in and work in the field of Clinical Psychology, Child Psychology, Speech Therapy, patient and next to kin counselling, running various activities like suicide prevention seminars, de-addiction seminar and workshops etc. Along with psycho-therapy, physiotherapy is given due importance at Krishna Hospital which has separate Physiotherapy OPD, Therapeutic Gymnasium, Mannequin Research Lab and a fully functional one of its kind Department of Prosthetics and Orthotics.

3.4.18 *Charity Schemes*

- 10 percentage beds total charity for indigent patients (I BED)
- 10 Percentage beds for weaker section (w/s).
- Survey of poor & destitute patients is done and free treatment card are distributed to them.

Patients with these cards receive totally free treatment including medicines, food & special investigations. There are economical weaker families from 37 villages adopted for free treatment. Two villages Khubi and Kapil have been adopted for 30% concession in IPD billing. Two slum areas Agashivnagar and Gopalvasti have been adopted for free medical treatment. Approximately 5000 people get free treatment in this institute every year. Ex-Servicemen & Freedom fighters are given free of charge treatment.

3.4.19 *National and International Collaborations*

- Indian Council of Medical Research
- National Aids Research Institute
- National Institute of Epidemiology
- National Institute of Virology
- Moving Academy of Medicine and Biomedicine
- Department of Health Sciences – Savitribai Phule University
- Defence Institute of Advanced Technology and many more.

3.4.20 *Service Collaborations*

- Prevention of mother to child transmission, PMTCT program.
- Janani Shishu Shuraksha Yojana, JSSY.
- Mahatma Jyotirao Phule Jeevand ayee Arogya Yojana, MJPJAY.
- Maharashtra Police Kutumb Arogya Yojana, MPKAY.
- NARI – National Aids Research Institute.
- All India Railway beneficiaries scheme (cashless).
- Ex-Servicemen Contributory Health Scheme, ECHS.
- Revised National Tuberculosis Control Program, RNTCP.
- Maharashtra Govt. free family planning surgery.

3.4.21 *Outreach Activities*

- HIV – AIDS awareness programs in urban & rural communities with special focus on reproductive age group of young adults.
- Sarva-Shiksha Abhiyaan.
- Cancer awareness program & cancer diagnostic camps.
- Dental health and oral cancer awareness camps.
- Blood donation camps.
- Sarva-roga Nidaan Shibir.
- Breast cancer awareness camps.
- Project for malnourished child (special project Krishna Laddu)
- Substance de-addiction programs and counselling.
- Personality development counselling for students during summer vacations.
- Aptitude testing camps for students.
- Suicide prevention through mental health awareness campaigns.
- Special campaigns addressing women's mental health.

3.5 OBJECTIVES OF STUDY

The main objective of the environmental audit is to know the existing environmental status & Management of same at institute and hospital campus.

The various objectives are as follows;

- To Identify & Quantify and Describe the framework of environmental aspects in compliance with applicable standards, regulations and Management policies.
- To introduce and make aware all the stake holders regarding institutional efforts about Environment,
- To analyzing the pattern and extent of resource use on the campus and its management w. r. t. sustainable development.

3.6 METHODOLOGY

In order to perform the successful Environmental audit, the following methodology is followed;

- Preparation Checklist and collection of documentation
- Physical inspection at various environmental related facilities of the campus
- To observation the conditions, take spot interviews, Collect samples and appraise the documentation
- Data analysis, measurements and recommendations.

The audit covers following ASPECTS;

- Water and Waste Water Environment
- Air Environment
- Solid and Land Environment
- Energy Environment
- Safety and Health Environment
- Social Environment

4.0 Environmental Aspects

Different environmental aspects are handled efficiently in the campus area. The data of all the environmental aspects are well maintained in the campus.

The details are as follows:

4.1 PRESENT INFRASTRUCTURE & AREA

The institute has been spread over area of 57 acres and the area distribution is as below;

Table 3.0: Area Statement for the Location

Sr. No.	Details	Area (In SQ. Mt)
1	Hospital campus area	233757
2	Tree cover of the campus	89784
3	Buildings	112166
4	Area of Utility	9891
5	Open Area	131355
6	Parking Area	4000

- The layout of the campus showing all details is enclosed as **Annexure I**
- The facility is well planned as per standard architectural norms providing adequate wide roads, open spaces, green spaces and adequate parking facility.

Table 4.0: Parking Allotment with Type of Parking

Parking Type	In Nos
2 wheeler	1035
4 wheeler	110
HMV	10
Bi cycle	45

Photograph 1: Parking Facility Provided by KIMSDU



The institute has state of art infrastructure with special facilities like;

- 100 super specialty beds
- 8 ICUs with 112 beds
- Emergency services with 30 beds and 6 ICU beds
- 20 NICU beds
- 40 private rooms
- 20 Deluxe Rooms
- 14 Super Deluxe Rooms
- Suites
- 2 Master Suites
- 13 ultra-modern operation theatres
- minor operation theatres
- Central Clinical Laboratory
- CT, MRI, Digital - X-Ray and imaging intensifier, Mammography.
- Sonography and Colour Doppler services.
- EEG, EMG, and Bera
- Eye Bank with Keratoplasty
- Central Research Lab
- Clinical and Demo rooms
- Psychology counsellors and Medical Social Workers
- Clinical Psychology
- Child Psychology
- Speech Therapy
- Psycho-therapy
- Physiotherapy
- Prosthetics and Orthotics
- Blood bank
- Components facility
- 24 * 7 Pharmacy
- Computerized Medical Records
- Department Offices and Library

4.2 WATER ENVIRONMENT

Water Pollution has assumed alarming proportions. It has emerged as one of the most serious environmental threats in India. Both domestic and industrial reasons are contributing to this problem. Excessive use of soap, soda, bleaching powder, detergent or acids at home and chemicals in the industries are primarily responsible for water pollution. Urban sewage and industrial waste flows into the water sources without treatment. Despite all efforts of the Government in cities and towns, only 10 per cent of the total waste water is treated and rest of polluted material directly flows into ponds, rivers and ocean.

Polluted water leads to the worst effect on human health. According to the World Health Organization (WHO), every year due to contaminated water 50 million persons become the victims of death. About 360 persons per one lakh die in India and over 50 per cent patients getting admitted in hospitals are the patients of water borne diseases. The situation in underdeveloped countries is even worse where over 80 per cent of the patients are suffering from the diseases born out of polluted water.

Microbes, toxins and water containing unnecessary amounts of salts give rise to many diseases. Around the globe, more than 80% of water borne diseases are due contaminated water. As per an estimate, almost 2.5 million people in over 34000 villages of India are suffering from cholera. Millions of tribal villagers in Rajasthan are suffering from various diseases due to drinking dirty water from the ponds. Contaminated water contains a variety of disease-causing bacteria that results in several types of ailment.

According to the scientists, a large number of diseases in India can be attributed to drinking of sewage mixed water. Various diseases like polio, cholera, patches, jaundice, fever, viral fever etc are spread through polluted water. Polluted water contains lead which when consumed by the humans while drinking water leads to producing various ailments such as joint pain, kidney disease and heart disease in them.

The waterborne diseases are infectious which spread primarily from polluted water. Hepatitis, cholera, dysentery and typhoid are the common waterborne diseases, which affect the majority of tropical area. Apart from diarrhea, and breathing problems, drinking polluted water causes skin diseases. If the polluted water gets stagnated, it becomes a breeding ground for mosquito and many other parasites which are very common in tropical areas. Children often get sick if they drink polluted water and sometimes they even die due to intensity of the diseases. As per an estimate, 13 children die per hour in India, due to diarrhea caused by contaminated water.

Polluted water is like poison for human beings. Large amounts of chloride in drinking water deform the spine which becomes snaky and their teeth go yellow, start falling and moreover their hands and feet lose flexibility of the bones and their body deforms. It also increases the risk of kidney diseases. A large amount of sulphide in polluted water is the reason of various respiratory diseases and drinking water contaminated with urea increases intestinal disorder. Thus continuous intake of contaminated drinking water is the reasons behind various stomach related disorders and other diseases like lumps in throat, tooth decay, etc. The factors causing most harm to human health through contaminated water are pathogenic microbes. Based on these, diseases generated by contaminated water are divided into the following main categories:

- a) By virus – Jaundice (Yellow Fever), polio, gastroenteritis, common cold, infectious liver Sod, and smallpox.
- b) By bacteria – Diarrhea, loose motions, paratyphoid, high fever, cholera, whooping cough, gonorrhea, syphilis, gastroenteritis, dysentery, and tuberculosis.
- c) By protozoa – Diarrhea, dysentery, narcolepsy (epidemic encephalitis), malaria, amoebiasis, and giardiasis.
- d) By worm – Filariasis, hydatid cyst and a variety of worm disease (various types of stomach worms).

Leptospirosis disease – In addition to organisms that cause disease in our body, various types of toxic substances harm our health reaching our body through water. The main toxic elements among them include cadmium, lead, nickel, silver, arsenic, etc.

- a) Excess quantities of iron, manganese, calcium, barium, chromium, copper, cillum, boron, and other salts such as nitrate, sulphate, borate, carbonate, etc in water have adverse effects on human health.
- b) The excess of magnesium and Sulphate in water irritates the intestines.
- c) In children, the excess of nitrate leads to the disease methemoglobinemia and generates stomach cancer by reaching the intestine.
- d) Fluorosis is a disease caused by excess of fluorine.
- e) Excess level of mercury in fish is dangerous especially for small children and pregnant women or nursing women. It interferes with the central nervous system development in the foetuses and young children.

Water pollution is dangerous for all life forms in this universe. Pollution of water leads to several illnesses.

4.2.1 **Water Management**

The Institute, hospital and hostel need fresh water for various purposes like domestic use, laboratory, green belt maintenance, washings, laundry etc. Water management and conservation is in good condition. Water Requirement on daily basis: The campus includes college, hospital, hostel, canteen etc. and the total water requirement is about 350 cum/day on peak load capacity.

4.2.1.1 **Source of Water**

Water is pumped through river as well as bore wells and some part delivered through Malakapur Municipal Council.

4.2.1.2 **Requirement, Waste generation, Treatment & 3 reuse practice**

The hospital has received consent to operate under water Act 1974, Air Act 1981, Authorization under rule 5 of the Hazardous Wastes (M, H & T M) rules 2016 and Biomedical Waste Management rules 2016 from Maharashtra Pollution Control Board. The copy of same is enclosed as *Annexure IV*.

Table 5.0: Water Uses in the campus are tabulated as follows

Sr. No.	Area	Water usage (Lit/day)
1	Garden	2,50,000 recycled from STP
2	Operation Theatres	8,000
3	General Wards	34,000
4	Special Wards	10,000
5	Cleaning	5,000
6	Canteen	8,000
7	Drinking	40,000
8	Toilets	25,000
9	Bathrooms	70,000
10	Washing	50,000
11	Construction works	40,000
12	Office uses	20,000
13	Urinals	12,000
14	Laboratories	28,000
Total		3,50,000

Table 6.0: Other Water data is as follows

SR. No.	Aspect	Details
1.	Water and Wastewater treatment system.	The hospital have following treatment systems in the premises: <ul style="list-style-type: none"> • Water Treatment Plant of 750 m3/d capacity • Sewage Treatment Plant of 2* 500 m3/d capacity • Effluent Treatment Plant of 100 m3/d capacity
2.	Water cooler with drinking water filtration.	<ul style="list-style-type: none"> • Aquagard44 Nos. • R.O. Systems 3 Nos. • Cooler 47 Nos.
3.	Number of urinals and toilets	<ul style="list-style-type: none"> • Western WC 710 Nos • Indian WC 405 Nos • Urinals 163 Nos
4.	Water pumps	<ul style="list-style-type: none"> • 2 Nos Pumps of 7.5HP • 5 Nos Pumps of 5.0HP • 1 No Pump of 20HP
5.	Quantity of water pumped	350 m3/d
6.	Number of water tanks for water storage	37 Nos
7.	Quantity of water stored	1600 m3

Water Wastage

Being an environmental conscious entity KIMSDU is aware of their responsibility and do regular check for identifying water leakages or wastages. At present there is no leakages or over usages of water identified.

Trade Effluent

The trade effluent is mainly from laboratory, laundry, operation theaters and other sources than the domestic effluent. The trade effluent is passed through a common drainage line and through coarse screen followed by oil and grease trap. The free and floating materials are collected from the screen chamber and disposed off as per the regulation. The oil skimming from the oil and grease trap are collected manually and disposed off as per regulation. The effluent then is collected in a collection tank and fed to the primary treatment unit comprising of flash mixer and settling tank. A dose of alum is added for enhancement of settling of solids in the settling tank. The sludge removed from the settling tank is discharged to sludge drying beds for natural drying. The dried sludge is disposed off to the CHWTSDF. The overflow of the settling tank is added to the MBBR tank of STP for further treatment. The treated effluent meets to the norms laid down by regulatory authorities. The management is carrying out 3rd party testing for trade effluent and domestic effluent

Domestic effluent

The raw sewage from various sources like toilets, canteen, etc. are collected through a common drain line and collected in a collection tank. The raw sewage is then pumped to screen chamber and oil and grease trap for removal of screenings and free and floating oil. The screenings and oil skimming are disposed off as per the regulatory norms. The overflow of the oil and grease trap is taken to MBBR (Moving Bed Biological reactor). The MBBR tank is provided with PVC fill media and diffused aeration system for biological treatment of sewage. The microorganisms are grown on the PVC fill media in the form of colonies and consume BOD from the sewage as their substrate. The air supplied from twin lobe type air blowers through the fine air bubble diffusers shall act as an energy source for microorganisms.

Third party certification of treated sewage and effluent: The untreated and treated trade and domestic effluents are tested on monthly basis through third party which is NABL and MOEF accredited.

A copy of report is enclosed as an *Annexure V*.

Schematic Diagram of STP is enclosed as *Annexure VI*

Photographs 2:Trade & Domestic Treatment Facility

4.2.2 Storm Water & Rain Water Harvesting

Storm water is any water running off a land surface before it reaches a natural water body. It occurs when the rate of precipitation is greater than it can infiltrate, or soak, into the soil. Runoff also occurs when the soil is saturated. Runoff remains on the surface and flows into streams, rivers, and eventually large bodies such as lakes or the ocean. Impervious surfaces such as driveways, sidewalks, and streets block rainfall and other precipitation from infiltrating naturally into the ground, leading to even more storm water and potential pollutant runoff.

The average rainfall in the region is 600 mm and the storm water management system is designed for peak rainfall of 100 mm. The campus has provided 2.0 m wide and 1.5 m deep trenches along the boundaries of the campus which are connected to the natural drainage outside of the campus. All roads and internal drains are connected to these storm water drains. All water on plain area and roofs is diverted systematically to these drains through the internal network of smaller drains of 0.5 M wide x 0.5m wide drains. The network of drains ensures that there is no flood like situation in the campus during peak rainfall. The harvesting of rain water simply involves the collection of water from surfaces on which rain falls and subsequently storing this water for use. The rain water collected can be stored for direct use or can be recharged into the underground aquifers. In scientific terms water harvesting (broadly) refers to collection and storage of rain water from the roof tops. This also restricts evaporation and seepage into building foundations.

A rain water harvesting system consists of:

- Roof catchment
- Down pipes
- Storage tanks/Pits/Sumps
- Ground water recharge structures like pit, trench, bore well, or combination of these structure.
- Rain / Storm water drains
- Filter chamber

RWH is a way to capture the rain runoff, store that water above ground or charge the underground aquifers and use it later. This happens naturally in open rural areas. But in congested, over-paved metropolitan cities, there is a need to devise methods to capture the rain water. The rain water that is incident on the surface / roof top is guided to bore wells or pits or new/old/abandoned wells through small diameter pipes to recharge the underground water which can be used later whenever required. Rain water can be harvested to the extent of 65,000 litres per 100 sq. m. area per year from roof tops.

KIMSDU has implemented full fledged Rain Water harvesting Plan in their premises.

Rainwater Harvesting certificate of Civil Department is enclosed as *Annexure VII*

Sr. No.	Building Name	Terrace area sq.m.	Water collection lac lit/year	Near Bore
1	BDS hostel	640	4.00	Bore no. 2
2	Ward no. 14,19	766	4.78	Bore no. 3

Photographs 3 : Rain Water Harvesting in KIMSDU



4.3 AIR ENVIRONMENT

For the Institute campus the indoor as well as outdoor air quality is very important. The outdoor air quality shall depend on levels of dust, traffic, greenery, quality of roads, level of air pollution due to other sources nearby etc. The immediate effects of poor outdoor air quality are hard to ignore. Watery eyes, coughing and difficulty breathing are acute and common reactions. An estimated 92 percent of the world's populations live in areas with dangerous levels of air quality and even at seemingly imperceptible levels; air pollution can increase one's risk of cardiovascular and premature death. Consistent poor air quality during pregnancy has been linked to miscarriages as well as premature birth, autism spectrum disorder and asthma in children. Poor air quality may damage children's brain development, and pneumonia, which kills almost 1 million children under the age of 5 every year, is associated with poor air quality resulting from air pollution. Children who breathe in higher levels of pollutants also face a greater risk of short-term respiratory infections and lung damage. Other conditions associated with high levels of poor air quality include emphysema and chronic bronchitis, as well as lung cancer. Pollutants can affect cardiovascular health by hardening the arteries and increase the risk of heart attack and strokes, and there is even emerging evidence that air pollution may be linked to mental health conditions and degenerative brain diseases such as Alzheimer's disease, Parkinson's disease and schizophrenia. While poor air quality due to air pollution's link to respiratory disease may seem obvious, its relationship to heart, brain and fatal health is less so. When the toxic soup of chemical particles and liquid droplets emitted by cars, power plants, fires and factories known as particulate matter is inhaled, the microscopic toxic dust can irritate nasal passages and result in an allergic-type response to the pollution, with symptoms like coughing and a runny nose.

Scientists believe that as the particles make their way deeper into the airways and into the lungs, the body may mistake it for an infection, triggering an inflammatory response. "When you have a bad head cold, you feel sick everywhere and your muscles might ache," Gerber said. "The same thing can happen when you breathe in pollution." Scientists also suspect that some toxic particles can escape the lungs and enter the bloodstream.

4.3.1 *Ambient Air Quality*

The Institute campus does not have incinerator or any other source of continuous emissions. The university campus has however provided 3 DG sets viz. 2 sets of 250 KVA and one 500 KVA capacities each as a stand by in case of power failure. The DG sets are used only in case of emergency. The fuel required for DG set is HSD (994Lit/month) and DG sets are provided with acoustic enclosure and stack of adequate height.

In order to maintain ambient air quality as per norms laid down by Central Pollution Control Board following precautions are taken by the management;

- Roads inside campus are tarred and concreted.
- Well-developed green belt is maintained. Roads are frequently cleaned and watered.
- Any civil work / repair work is done with proper cladding. Material movement is done in closed trucks.
- Only PUC certified vehicles are allowed in the campus.
- The hospital campus in collaboration with Central Pollution Control Board is setting up continuous online ambient air quality monitoring station.

Photographs 4: DG Set with adequate Stack Height as per Consent

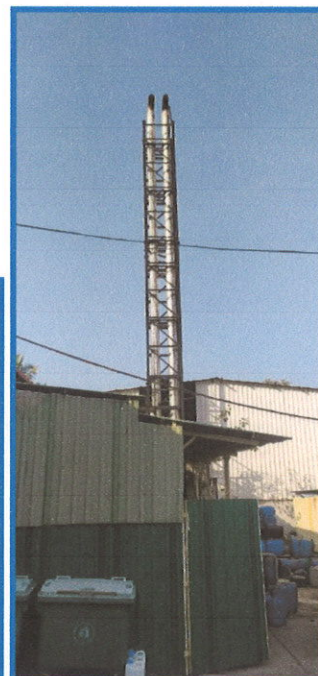

4.3.2 *Indoor Air Quality*

Hospitals are the places we visit to get treatment in the case of any health-related issues. However, we often ignore that hospitals are also the host to many types of air pollutants hence causing airborne infections, commonly referred to as “Hospital Acquired Infection” [HAI]. Poor Indoor Air Quality inside healthcare facilities is more harmful as compared to bad indoor air of any other place, like hotels or workplaces as other than dust and other pollutants, it involves hospitals and pharmacy related chemicals, and various types of known and unknown bacteria and viruses responsible for spreading cross infections. According to the World Health Organization, at any given time over 1.4 million people across the globe suffer from a nosocomial or HAI (Hospital Acquired Infection). HAIs account for 2 million ailment cases and about 80,000 deaths a year. Hence, it becomes really important for healthcare facilities to maintain the indoor air quality to safeguard patients, staff, caregivers and also the visitors from hospital- acquired infections. Before we dive into the solutions, let us first understand the main factors responsible for poor air quality inside healthcare facilities and where are they found;

1. **Outpatient Departments** : OPDs are the busiest areas in any hospital. Many of these patients are carriers of harmful bacteria and viruses and they are highly infectious because their medication hasn't even started. They all sit in the same room for hours and this might cause cross infection to others and also to the doctor and other staff.
2. **Operation Theatres** : Surgical care is one of the most crucial and integral parts of healthcare however, it is also associated with risks related to infections. Surgical site infections (SSIs) remain one of the most common causes of serious surgical complications in Healthcare Associated Infections (HAI) and one of the main factors for these infections is circulation of stale air and poor air quality.
3. **Intensive Care Unit** : Several patients are kept inside the Intensive Care Unit for observation and also to protect them from outside infection. A visit to by any outsider to ICU is often taken with precautions still the prevalence of HAI remains really high in ICUs. And, this influences the mortality and morbidity pattern of ICUs.
4. **Maternity wards, Neo-natal and Paediatric ICUs**: Maternity wards and Paediatric ICUs can be breeding grounds of several infections and they affect mothers and infants at a time when they are most vulnerable.
5. **Waiting areas and halls** : These are the places where people gather in large numbers and not all healthcare facilities are adequate enough to maintain cleanliness and proper air quality in these spaces, hence it enhances the risk of infections amongst visitor and caregivers.

6. Storage units

It is really important for the staff to maintain the hygiene of storing places because just the presence of fungi in hospital air is a matter of great concern as many spores can be released leading to an incidence of HAIs and occupational infections.

How to improve The above are just a few examples of how the infection spreads through impure Air in Hospitals, clinics, diagnostics labs, etc. There are several other sources through which HAI can spread.

Indoor Air Quality at KIMSDU

The hospital is taking following steps to improve the Indoor Air Quality.

- a. Presence of patients is the main reason for any hospitals for maintaining the IAQ but patients are also the major source of air contaminants, like bacteria, viruses and foul smell coming from the wounds and other infections. The facility staffs comes in direct and immediate contact with patients so it is important for staff to use proper masks and gloves while handling patients and follow all hygiene protocol designated & facilitated for them.
- b. Protocols for housekeeping as per the various departments of hospital are fixed and critically followed.
A few documents related to protocols, check points, recruitment of staff for housekeeping are enclosed as Annexure VIII.
- c. Adequate ventilation and illumination is provided as per standards.
- d. Proper humidity is maintained.
- e. HVAC system is provided to maintain proper quality in wards, operation theaters, and various departments.
- f. Differential Pressure controls are maintained as per standards.

The hospital maintains following standards of various measures to keep the indoor air quality as per norms. Following Air changes are maintained for various departments;

Table 7.0: Indoor Air Monitoring Details

Area	Outdoor air	Total air	Outdoor air
	change rate	change rate requirement	
	ACH*	ACH	L/s/Person
Patient room	2	4	13
Operating theatre	15	15	15
Intensive care unit	2	6	8
Infectious isolation room	2	6	–
Protective isolation room	2	15	–
Laboratory	2	6	–
Delivery room	15	15	–

The Filtration systems are provided at various departments with following efficiencies;

Area	Filter	
	Pre-filter	Final Filter
Patient room	25–30%	90%
Infectious isolation room	25–30%	90%
Protective isolation room	25–30%	90–99.97%
Intensive care unit	25–30%	90%
Delivery room	25–30%	90%
Laboratory	80%	--
Operating/surgical room	25–30%	99.97% (90%Plus Additional)

Thus the hospital campus is taking proper care to maintain very good quality of outdoor as well as indoor air quality.

4.4 WASTE GENERATION & MANAGEMENT

The hospital campus is generating various types of hazardous and non-hazardous solid wastes as under. Waste, E Waste, Municipal Solids Waste, Non Hazardous waste like metal scraps, papers etc.

The hospital has also made SOP for condemnation of disposal of items wide Doc. Under the said SOP detailed procedure is outlined for disposal of various items.

4.4.1 *Biomedical Waste*

The Ministry of Environment and Forests and Climate Change has published Biomedical Waste Rules in 2016 wide GSR 343 (E) dated 28th Mar 2016 and the same are subsequently amended in the year 2018 wide GSR 234 (E) dated 16th Mar 2018.

The notification specifies the practice to be followed for disposal of biomedical waste and compliances to be made.

The hospital has obtained authorization for bio medical waste from Maharashtra Pollution Control Board.

Bio-medical waste means waste, which is generated during the activities performed at;

- Medical enterprises and those are like diagnosis, treatment of human beings or animals,
- Medical research activities,
- Production or testing activities involved biological phenomenal.

These different wastes are categories and mentioned in Schedule I appended to BMW Management Rules.

Bio Medical waste consists of categories with color code ;

- 1 Yellow : Human anatomical waste, Animal anatomical wastes, Soiled Wastes, Expired or Discarded Medicines, Chemical Wastes, Chemical Liquid Wastes, Discarded Materials (Ex. Bed sheets, etc), Microbiology, Biotechnology and other clinical laboratory waste,
- 2 Red : Contaminated Waste (Recyclable)
- 3 White : Waste sharps including Metals
- 4 Green : Glass Ware, Metallic Body Implants

Main groups at risk are

- Facility Owners, Handlers,
- Doctors, Nurses, Paramedical workers
- Patients & Visitors establishments
- Workers involved direct and Indirect services along with and its allied services such as laundry activity, waste handling, segregation and transportation
- Workers involved at waste facilities e.g. landfills, incinerators, Etc.

Need of biomedical waste (BW) management in hospitals

The reasons due to which there is great need of management of hospitals waste are listed out and those are ;

- BW sharps may lead to injuries and are infectious for all concern people involved in the activity.
- Poor infection control and waste management have adverse impacts. .
- Risk of infection outside the hospital environment & Public. Also to those who handle to it, scavengers and sometimes general public living in the vicinity of hospitals.
- High Risk due to handling of various categorized waste hazardous chemicals, drugs to persons handling wastes.
- Malfunctioned activities such as, Disposable materials are repacked, sold without any standard practice.
- Expired Drugs, being repacked and sold.
- Risk of air, water and soil pollution directly or indirectly due to waste handling and its disposal practices such as defective mechanism, emissions and waste such as ash.

BMW Management at KIMSDU

The biomedical waste from the hospital campus is categorized in four categories as per the BMW rules. The waste arising out of various departments is sorted out and stored in dedicated containers with Yellow, White, Red and Blue color. The waste is segregated, Stored with classification as per Categories mentioned in BMW rules. The category wise waste is weighted and documented. The waste is daily collected by the Authorized facility operator for scientific storage and scheduled disposal practice. The records of daily waste generation and disposal are maintained by the concerned department. A system of gate pass is maintained at the time of handling over waste to the Authorized representative of facility operator. A sample copy of documentation maintained is enclosed as *Annexure IX*.

Photographs 5 : Biomedical Waste Management in KIMSDU



4.4.2 E- Waste

Electronic waste (e-waste) is when electronic products that have come towards the end of their “useful life.” Recycling of used electronic devices is important to make sure that we are protecting the environment. Following are 5 reasons why electronic waste is such a problem

1. Electronic waste keeps growing and growing
2. Environmental effects of e-waste
3. Tons of e-waste is shipped overseas
4. Health implications of electronic waste
5. Electronic waste and data security

In order to have scientific management of E Waste the Ministry of Environment and Forests and Climate Change has published E Waste Management rules wide GSR 338 (E) dated 23rd Mar 2016 and the same are subsequently amended wide GSR 261 (E) dated 22nd Mar 2018. These rules makes every manufacturer, producer, consumer, bulk consumer, collection centres, dealers, e-retailer, refurbishes, dismantler and recycler involved in manufacture, sale, transfer, purchase, collection, storage and processing of e-waste or electrical and electronic equipment listed in Schedule I, including their components, consumables, parts and spares which make the product operational to meet the compliances as specified in these rules.

The KIMSDU management of the Institute has entered into agreement with authorised party, for disposal of E Waste generated from the hospital and institute campus. The said firm has valid consent to operate from Maharashtra Pollution Control Board. The disposal of E Waste is documented by the concerned department giving all details of the equipment’s to be disposed off like Name of Equipment, Serial Number, Model, Make and Quantity. The E Waste is handed over to the authorized recycler as per the rules of E Waste rules. A sample copy of same is enclosed as *Annexure X*.

Photographs 6 :E- Waste Management in Institute



4.4.3 *Municipal Solid and Other Wastes Management at KIMSDU Campus*

The ministry of Environment and Forests and Climate Change has published notification for handling of Municipal and other solid waste wide GSR 1357 (E) dated 8th Apr 2016 which apply to every urban local body.

The hospital campus generates various types of waste like food waste from canteen and mess, lawn cuttings, tree leaves, papers, metal scrap of various types, waste material etc. These wastes are segregated into various categories like bio degradable and non- biodegradable. A dedicated area is marked for storage of these types of wastes. Only authorized persons are allowed to enter the same. The biodegradable waste from the whole campus consisting of food waste, tree leaves, lawn cuttings is estimated to be 600 to 700 kg/day. The said waste is converted into bio compost through waste composter of capacity 1000 kg/day. Special microbial culture is used for accelerating the bio composting process. The bio compost is used as manure for green belt in the campus. Other waste is segregated as per the category and is sold to authorized recycler. The records of waste disposed are maintained by the stores department.

Photographs 7 :Bio-Composting (Clean India Initiative)

	
<p>Waste Composter Plant</p>	<p>Manure stored near Composter</p>

4.5 ENERGY ENVIRONMENT

Electricity in Institute is used for wide variety of purposes like lighting, cooling/heating equipment, Vacuum & air compressors, water pumps, fans, laundry, kitchen, medical equipment's, ovens, etc. The institute campus is presently buying electricity from Maharashtra State Electricity Distribution Co. Ltd. The hospital campus has sanctioned load which is well within connected load. The average monthly unit consumption is 350,000 units. The Reports and the records are maintained at Electrical Department.

The Sample is enclosed as *Annexure XI*

Energy Conservation/Use of Non-Conventional Energy Sources

The KIMSDU has installed 500 KWP solar panels in the campus. The average power generation for solar power is @ 60000 units/month. This shall result in saving of @ 64800 kg of emissions of CO₂. This shows the commitment of management towards sustainability.

Photographs 8 : Solar System Installed at Institute



Following energy conservation measures are undertaken by the management;

- Maximizing usage of natural light during the day through passages and corridors;
- Turning off office equipment, fans and air-conditioners during unoccupied hours;
- Educating people about reasonable and efficient usage of water heaters and other electrical appliances;
- Plugging air leakages in air-conditioned rooms such as office spaces, operation theatre;
- Turning off water pumps when the tanks filled up
- Catchy campaigns that made use of easy to remember slogans;
- Use of various communication tools such as posters at strategic locations to inform staff of the steps that can be taken to conserve energy and minimize wastage
- Installation of Lighting controls including timers and occupancy sensors
- Use of Variable Speed Drives (VSD)
- Upgrades to Heating Ventilation Air-Conditioning and Cooling (HVAC)
- Dampers, actuators and controls
- Voltage Regulation Units (VRUs)
- Demand response management
- Building Automation
- Building sealing

4.6 SAFETY AND HEALTH ENVIRONMENT

Hospitals are representative of complex environment in which different aspects including patients, staff, equipment, services, and information are interfaced. Maintaining a safe environment with respect safety and health reflects a level of competent healthcare that must be fulfilled for patient safety. In this context, the clinical engineer plays an important role in providing safe environment within hospital.

4.6.1 Fire Safety

Following provisions have been made to deal with fire safety.

- a. Provision of Full fledge fire detection, fire hydrant and fire extinguishers system as per the requirement.
- b. Disaster Management Plan for the whole campus is in place. The Copy is available at Fire Department and, Security, Management Representative, Environment Officer.
- c. Regular fire drills and trainings are undertaken and records are maintained. A copy of sample Fire Mock Drill & Record is enclosed as *Annexure XII*.
- d. Fire escape plan are made and are displayed at various locations. The fire exits are well defined and end on the ground floor or refuge area or any safe place decided by the management. The Fire Signage's are appropriate and placed at the right locations. Emergency fire signage's are glow in dark signage's. The Fire Signage's are visible and are bilingual, with one local language. The egress routes are free from any materials that would cause hindrance in the evacuation. The Fire Doors have a proper fire rating and open outside.
- e. The campus has implemented Code Red system for fire emergency
- f. All the equipment have an organized preventive maintenance schedule that is recorded and stickers put on the computer showing the date of preventive maintenance check and the next time for maintenance. Fire systems are regularly checked and the records are made by Fireman. A sample copy of records is enclosed as *Annexure XII*.
- g. A plan showing locations of fire hydrants / fire extinguishers is displayed at prominent location.
- h. The appropriate type and several fire extinguishers have been installed according to the kind of fire that could take place like Kitchen, MRI, Electrical room, data centre area The Fire Extinguishers have a regular preventive maintenance schedule and stickers are put

showing the date of checking and the next scheduled date for verification. Approx. 10% of Fire Extinguishers are used every year for checking the same. Fire extinguishers are regularly checked and replenished before the expiry period. A contract with the competent agency is made for same.

- i. A multidisciplinary safety committee is formed, with a senior person as the chairman of the safety committee. The safety committee meetings are held at least once in a month.
- j. The organization has appointed Fire Safety Officer-in-charge of all concerns related to Fire Prevention & Safety.
- k. It also has a written plan for Fire Prevention and Safety and has a Fire Safety Manual approved by the safety committee.
- l. It also has an Emergency Command Centre that becomes functional immediately whenever there is an emergency. There are a written protocol and written constitution for the committee. The Fire Command Centre is also updated with the name of the members. A designated person has the responsibility of informing all the Emergency Command members.
- m. The HVAC system has appropriate fire dampers to prevent the spread of the fire that functions correctly in case of fire. The dampers are tested and have a regular preventive maintenance schedule.
- n. Gas cylinders and medical oxygen cylinders are secured and stored properly. Medical oxygen monitoring system is in place.

4.6.2 ***Patient and Staff Safety***

The hospital has well laid SOP for patient and staff safety. The document covers following important aspects;

- a. Defining Policy
- b. Formation of Safety Committee
- c. Defining role of committee.
- d. Monitoring of sentinel / adverse events and near misses.
- e. Staff safety related to prevention of HAI
- f. Environmental safety aspects covering smoking limitation policy, patient safety, facility building and installations.
- g. Various safety related SOP's like Smoking Limitation Policy, Radiation Safety Program, safety in labs, management of hazardous material , safety related to medical gases, needle

handling policy, disinfection and decontamination protocols and incident reporting are in place.

- h. Safety related quality indicators are fixed for various mock drills, incidences of falls in hospital, number of sentinel events and critical equipment down time.

Photographs 9: Fire Fighting System at KIMSDU



4.6.3 *Radiation Safety*

Radiation protection is a public health issue for a number of reasons. First, health effects of radiation are not unique. Second, individuals have only a limited ability to structure or control their own environment. Although radiation exposure awareness has increased among the general public, there is still very little monitoring of cumulative radiation exposure over a patient's lifetime. Successful radiation safety programs must balance engineered safety and personnel training considering technical, scientific, economic, human, and ethical aspects of radiation use. The medical safety programs must adequately protect patients, care givers, visitors, and the general public.

Non ionizing radiation is also a significant health hazard in all hospitals. This type includes ultraviolet, microwave and laser radiation. Ultraviolet (UV) radiation is frequently used in sterilization procedures. In fact, UV exposures are best controlled by limiting exposures as function of energy. In application, Microwave radiation is commonly used in hospital diathermy treatment and in microwave ovens. Microwave radiation is controlled by limiting exposure and sources should be periodically surveyed with measurement equipment. On the other side, Lasers have an increasing role in medical treatment. Eyewear is the most common method of protection.

The hospital has well laid protocols and procedures for radiation safety.

In case of handling of equipment's like MRI/CT Scan/X-Ray, following precautions are taken;

- a. MRI Machines
- b. MRI Machine Rooms are isolated Properly from surrounding with key locking door
- c. MRI technician is properly trained
- d. MRI compatible ventilator available for emergency
- e. All warning signed are displayed in waiting area CT scan / X-Ray Machines
- f. The CT gantry room walls are 9' and are lined by 2mm lead sheet
- g. Technicians are properly trained
- h. All warning signs are displayed outside CT scan area
- i. Lead Apron provided to staff
- j. Periodical QA performed for machine
- k. Do's and Don'ts Displayed on Machine

4.6.4 *Infection Control*

Infection control provides a framework for identification of a hazard and development of an action plan to eliminate the hazard or minimize its effect through control measures. Control has been achieved by recognizing the means of growth, reproduction and transmission of pathogenic microorganisms. The main components of an effective infection control program are listed as following.

The hospital management is taking effective steps related to same in following manner.

- a. Education and training to staff
- b. Surveillance of infection
- c. well defined Policies, procedures, and guidelines
- d. Conducting regular Audit's.
- e. Regular Monitoring of hospital hygiene

Following Standard precautions are being taken

- a. Hand washing and antiseptis (hand hygiene)
- b. Use of personnel protective equipment when handling blood, body substances, and secretions
- c. Appropriate handling of patient care equipment and soiled linen
- d. Prevention of needle stick / sharp injuries
- e. Environmental cleaning and spills-management
- f. Appropriate handling of waste

Additional(transmission-based)precautions while ensuring standard precautions include;

- a. Airborne precautions
- b. Droplet precautions
- c. Contact precautions

4.7 NOISE / AESTHETICS / SOCIAL ENVIRONMENT

Noise is defined as unwanted sound. Several studies have been conducted for hospital noise that linked hospital noise to a variety of negative physiological outcomes. The WHO has recommended that noise level should not exceed 35 dB in rooms where patients are treated or observed and 30 dB in wards rooms. Hospitals have various sources of noise such as alarms, paging systems, telephones, computer printers, televisions, delivery carts, staff conversation, equipment, housekeeping activities, air conditioning systems, doors opening and closing, and sounding systems. Of course, one physical effect of the noise is human stress which should be avoided in hospital environment. Topf and Dillon (1988) have described human effects due to noise-induced stress as decrease in sustained attention, rapid detection, multiple single tasks, and incidental memory.

To overcome the problem of noise within hospitals, following preventive procedures are being carried out.

- ✓ A regular check and maintenance to all systems that are considered as sources of noise including equipment.
- ✓ Regular Monitoring of noise levels
- ✓ Acoustic enclosure to high noise machine like DG set.

Aesthetics / Green Belt

The hospital campus has provided 38% of total area for green belt and open spaces. Various types of trees (@ 3000) are planted in the campus and treated sewage is being used for green belt development.

Photographs 10 :Green Belt Development at Campus



Social Environment

The institute provides direct and indirect employment over 3000 persons. Various CSR activities are carried out by the hospital like Medical camps, Free Medicines to the needy, Free food to poor patients, Free treatment to the poor patients, Awareness programs for Breast Feeding.

5.0 Conclusion

The Green Scientific Development (I) Pvt. Ltd. audit team carried out environmental audit as per the schedule set for the site covering all the campus activities and its environmental essential aspects for the set objective. The audit included filling checklist, Physical inspection during site/field visit, verifications of documentation, discussions/interview with concern department person and Sample/Evidence collection.

The data and evident collected, verified and checked for its compliances w. r. t. legal and other requirements applicable for KIMSDU, Karad and found to be satisfactory and meeting to the compliances with applicable standards, regulations and Management Policies.

In nutshell, the organization is using resources as per optimum requirement and managing all the environmental aspects sustainable way with continual improvement. The compilation of Audit findings are as follows;

Table 8.0: Compilation of Environmental Audit Report

Environmental Aspects	+ Ve Observation	Non Conformity Major (M)	Non Conformity Minor (m)	AREA For Improvement / Recommendation
Legal Compliances	Y	No	No	No
EMS Activity	Y	No	No	AFI ¹
Water Environment	Y	No	No	No
Air Environment	Y	No	No	No
Bio Medical Waste	Y	No	No	No
E Waste	Y	No	No	No
MSW & Other waste	Y	No	No	No
Energy	Y	No	No	No
Safety & Health	Y	No	No	No
Radiation Safety	Y	No	No	No
Infectious Management	Y	No	No	No
Noise / Aesthetic/ Social Env.	Y	No	No	No

Y – Yes, N – No, AFI-Area for Improvement, AFI^{*}-* Number of AFI

5.1.1 *List of the Area for improvement (AFI)*

AFI¹ : As all most all the ISO requirements are in place, KIMSDU can apply for ISO 14001:2015 certification.

5.1.2 *Positive (+ Ve) Observation*

- Facility is compliancing all the legal & other requirements.
- Installed and handling all the pollution abatement facilities successfully without any non compliance.
- The Management is fully involved in the EHS activity positively with the funds and resource provision.
- Natural Resource Management and Reuse recycle & Recovery principle are in place.
- Wastewater fully treated and recycled back for its reuse and reducing consumption of Fresh water.
- RWH is implemented in the premises to the possible extend.
- Use of Renewable energy is providing with the provision of Solar Panels.
- Ambient Air, Indoor Air Quality maintained satisfactorily.
- Noise Environment is to the mark for sensitive area.
- Solid Waste, E-waste management facilities are established as per requirement and operations are handled satisfactorily.
- Bio Medical Waste collection, segregation, storage and disposal found compliancing requirement of Bio Medical authorization issued by MPCB.
- Radiation management is to the mark
- Pollution parameter monitoring is carried out regularly.
- Fire and Safety aspects t the premises handled to the mark.
- Tree Plantation is carried out and green belt is maintained.
- CSR is planned and regularly implemented.

ANNEXURES

**ENVIRONMENTAL AUDIT REPORT
FOR KIMSDU**

September 27, 2019

List of Annexure

ANNEXURE I	LAYOUT OF CAMPUS	2
ANNEXURE II	LEAD AUDITOR CERTIFICATE.....	3
ANNEXURE III	WATER CONSUMPTION REPORT	4
ANNEXURE IV	VALID CONSENT COPY OF KIMSDU BY MPCB.....	5
ANNEXURE V	3 RD PARTY REPORTS FOR TRADE & DOMESTIC EFFLUENTS (OLD & NEW STP).....	9
ANNEXURE VI	SCHEMATIC DIAGRAM OF STP.....	10
ANNEXURE VII	CERTIFICATE FOR WORK DONE FOR RAIN WATER HARVESTING & STORM WATER MANAGEMENT	11
ANNEXURE VIII	DOCUMENTS RELATED TO PROTOCOL, CHECK POINTS, RECRUITMENT OF STAFF FOR HOUSEKEEPING.....	12
ANNEXURE IX	SAMPLE DOCUMENTATION MAINTAINED FOR BMW.....	14
ANNEXURE X	THE DISPOSAL OF E-WASTE IS DOCUMENTED BY THE CONCERNED DEPARTMENT.....	17
ANNEXURE XI	REPORT SHOWING UNIT CONSUMPTION FROM ELECTRICITY SOURCED FROM MSEDCL & FROM OWN SOLAR POWER GRID	18
ANNEXURE XII	FIRE MOCK DRILLS & TRAINING	19

Annexure I Layout of Campus

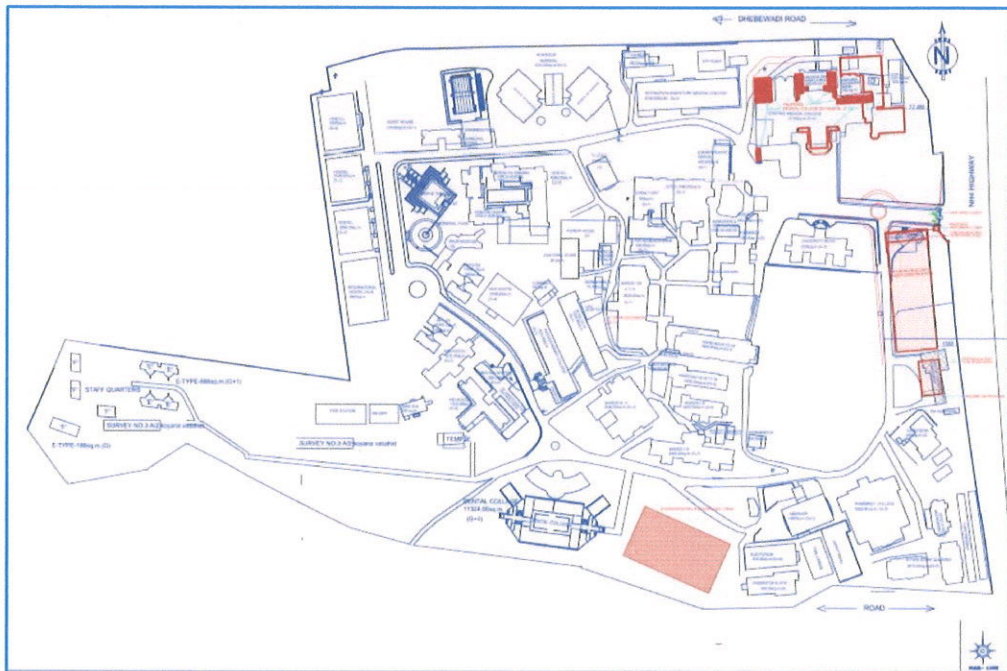
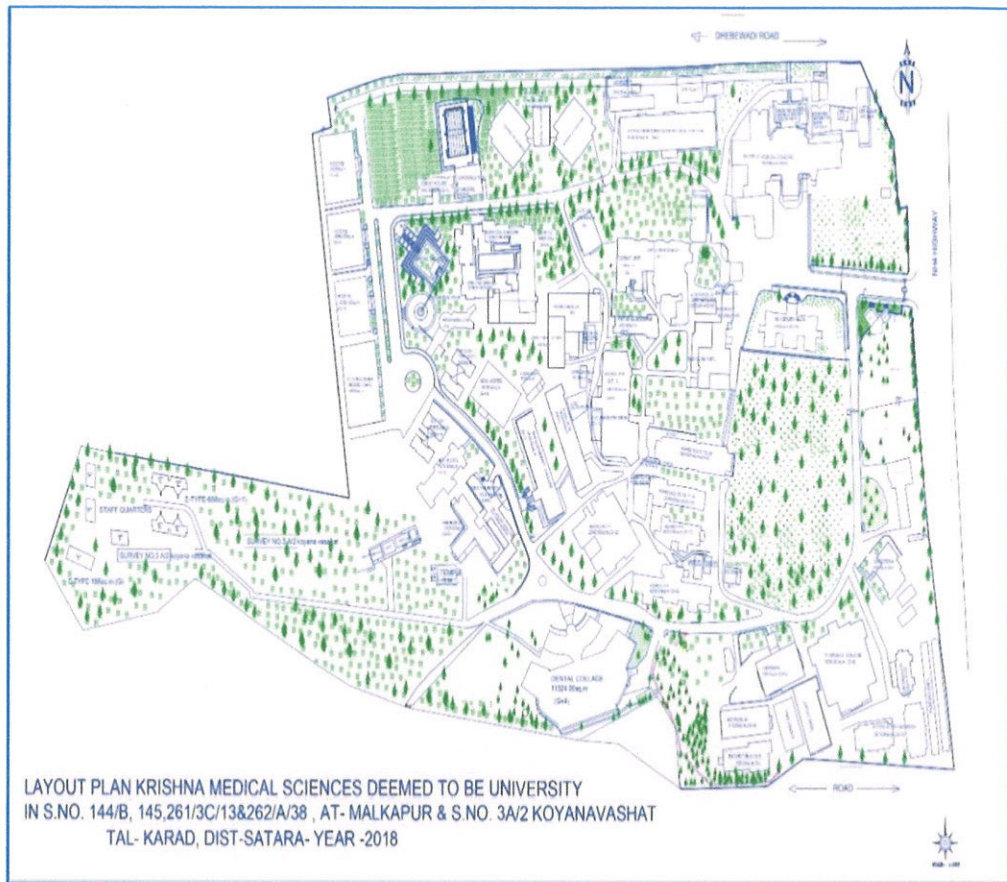

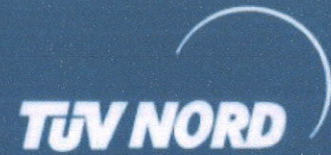

**PR315: ISO 14001:2015 Lead Auditor
(Environmental Management Systems)
Training course**

Certificate of Achievement

Mr Kiran M Shinde

has successfully completed the above mentioned course and examination.

11th - 15th March 2019

MUMBAI, INDIA

Certificate No. 35242852 02

Delegate No. 168345

for TÜV NORD CERT GmbH

Essen, 2019-04-15

The course is certified by CQI and IRCA (Certification No. 18125). The learner meets the training requirements for those seeking certification under the IRCA EMS Auditor certification scheme.

TÜV NORD CERT GmbH

Langemarckstraße 20

45141 Essen

www.tuev-nord-cert.com



ANNEXURE III Water Consumption Report

**KRISHNA INSTITUTE OF MEDICAL SCIENCES DEMMED TO BE
UNIVERSITY, MALKAPUR KARAD, DIST-SATARA.
KRISHNA CHARITABLE TRUST, MILKAPUR KARAD.**

Dept.Name- **Civil/Maintenance Dept.**

Sangli Pathbandhare vibhag , Sangli , Inward No.6093
Koyana Rever Water Permission - 7th sept.1991
27,50,00,000 Lit/Year (7,50,000 Lit/day)
Water Storage Tank Capacity 7,50,000 Lit./Day

Water Consumption Report - 2018

Month	Per day Water Consumption	Checked By
May	7,16,000	
June	5,89,000	
July	7,28,000	

Building	No. of persons
Hospital & OPD	2375
Hostels	1850
College & University building	2000
Total Persons	6225

Average water consumption per day = 6,77,666 lit/day

Average water consumed / person = Average water consumption/ Total person
=6,77,666/6225

Average water consumed /person =108 lit.

J. M. G. T. P. S. V.
CIVIL INCHARGE
K.I.M.S.D.U., KARAD

**Schedule V
General Conditions**

- 1) The applicant shall provide facility for collection of environmental samples and samples of trade and sewage effluents, air emissions and hazardous waste to the Board staff at the terminal or designated points and shall pay to the Board for the services rendered in this behalf.
- 2) Industry should monitor effluent quality (stack emissions and ambient air quality monthly/quarterly).
- 3) The applicant shall provide ports in the chimney(s) and facilities such as ladder, platform etc. for monitoring the air emissions in the lanes shall be designated by numbers such as S-1, S-2, etc. and these shall be properly displayed to facilitate identification.
- 4) Whenever due to any accident or other unforeseen act or event, such emissions occur or is apprehended to occur in excess of standards laid down, such information shall be forthwith Reported to Board, concerned Police Station, office of Directorate of Health Services, Department of Explosives, Inspectorate of Factories and Local Body in case of failure of pollution control equipment, the production process connected to it shall be stopped.
- 5) The applicant shall provide an alternate electric power source sufficient to sustain pollution control facilities installed to maintain compliance with the terms and conditions of the consent.
- 6) The firm shall submit to this office, the 30th day of September every year, the Environmental Statement Report for the financial year ending 31st March in the prescribed Form as per the provisions of rule 14 of the Environment Protection (Second Amendment) Rules, 1987.
- 7) The industry shall recycle/reprocess/reuse/recover hazardous waste as per the provision contain in the new Hazardous Waste Rules, 2016, which can be recycled/recovered/reused and only waste which has to be incinerated shall go to incineration and waste which can be used for land filling and cannot be recycled/reprocessed etc should go for that purpose, in order to reduce load on incineration and landfill site/environment.
- 8) The industry should comply with the Hazardous Waste (M, H & TM) Rules, 2016 and submit the Annual Returns as per Rule 5(1) & 2(2) of Hazardous Waste (M, H & TM) Rules, 2016 for the preceding year upto 15th March in terms by 30th June of every year.
- 9) An inspection book shall be prepared and made available to the Board's officers during their visit to the applicant.
- 10) The applicant shall make an application for renewal of the CCA at least 60 days before the date of the expiry of the CCA.
- 11) Industry shall strictly comply with the Water (PCCP) Act, 1974, Air (PSC) Act, 1980 and Environment Protection Act, 1986 and industry specific standards under EP Rules 1986 which are available on MPCB website (www.mpcb.gov.in).
- 12) The industry shall contribute an Environmental cell with qualified staff/personnel/agency to see the day to day compliance of consent conditions towards Environment Protection.
- 13) Separate drainage system shall be provided for collection of trade and sewage effluents, rain water and storm water. The drainage system shall be provided with arrangement for measuring the flow and it may occur than in the pipes/downstream of the terminal manholes. No effluents shall be allowed to discharge from other premises shall be allowed to mix with the effluents in the factory.
- 14) The applicant shall install a separate meter showing the consumption of energy for operation of domestic and industrial effluent treatment plants and air pollution control system. A register showing consumption of chemicals used for treatment shall be maintained.
- 15) Conditions for D.G. Set
 - a) Noise from the D.G. Set should be controlled by providing an acoustic enclosure or by treating room acoustically.
 - b) Industry should provide acoustic enclosure for control of noise. The acoustic enclosure/acoustic treatment of the room should be designed for minimum 25 dB (A) insertion loss or for meeting the ambient noise standards, whichever is on higher side. A suitable exhaust muffler with insertion loss of 25 dB (A) shall also be provided. The measurement of insertion loss will be done at different points at 0.5 meters from acoustic enclosure/room and then average.
- 16) Industry should make efforts to bring down noise level due to DG set, outside industrial premises, within ambient noise requirements by proper siting and control measures.
- 17) Installation of DG Set must be strictly in compliance with recommendations of DG Set manufacturer.
- 18) A proper routine and preventive maintenance procedure for DG set should be set and followed in demarcating with use.
- 19) D.G. Set shall be operated only in case of power failure.
- 20) The applicant should not create any nuisance in the surrounding area due to operation of D.G. Set.
- 21) The applicant shall comply with the notification of MoEF dated 17.03.2002 regarding noise limit for generator sets in with cities.
- 22) The industry should not cause any nuisance in surrounding area.
- 23) The industry shall take adequate measures for control of noise levels from its own premises within the premises in an to maintain ambient air quality standard in respect of noise to less than 70 dB (A) during day time and 70 dB (A) during night time. Day time is reckoned in between 6 a.m. and 6 p.m. and night time is reckoned between 10 p.m. and 6 a.m.
- 24) The applicant shall maintain good housekeeping.
- 25) The applicant shall submit a yearly statement by 30th September every year on available open plot area, number of trees surviving as on 31st March of the year and number of trees planted by September and so as not to cause any nuisance / pollution. The applicant shall take necessary permissions from local authorities for disposal of solid waste.
- 26) The applicant shall not change or alter the quantity, quality, rate of effluent, temperature on the mode of effluent/emissions or hazardous waste or control equipments provided for without previous written permission of the Board. The industry will not carry out any activity, for which this consent has not been granted without prior consent of the Board.
- 27) The industry shall ensure that fugitive emissions from the activity are controlled so as to maintain clean and safe environment in and around the factory premises.
- 28) The industry shall submit official e-mail address and any change will be duly informed to the MPCB.
- 29) The industry shall achieve the National Ambient Air Quality standards prescribed vide Government of India Notification dt. 16.11.2009 as amended.

-0000-

**Schedule V
General Conditions**

- 1) The applicant shall provide facility for collection of environmental samples and samples of trade and sewage effluents, air emissions and hazardous waste to the Board staff at the terminal or designated points and shall pay to the Board for the services rendered in this behalf.
- 2) Industry should monitor effluent quality (stack emissions and ambient air quality monthly/quarterly).
- 3) The applicant shall provide ports in the chimney(s) and facilities such as ladder, platform etc. for monitoring the air emissions in the lanes shall be designated by numbers such as S-1, S-2, etc. and these shall be properly displayed to facilitate identification.
- 4) Whenever due to any accident or other unforeseen act or event, such emissions occur or is apprehended to occur in excess of standards laid down, such information shall be forthwith Reported to Board, concerned Police Station, office of Directorate of Health Services, Department of Explosives, Inspectorate of Factories and Local Body in case of failure of pollution control equipment, the production process connected to it shall be stopped.
- 5) The applicant shall provide an alternate electric power source sufficient to sustain pollution control facilities installed to maintain compliance with the terms and conditions of the consent.
- 6) The firm shall submit to this office, the 30th day of September every year, the Environmental Statement Report for the financial year ending 31st March in the prescribed Form as per the provisions of rule 14 of the Environment Protection (Second Amendment) Rules, 1987.
- 7) The industry shall recycle/reprocess/reuse/recover hazardous waste as per the provision contain in the new Hazardous Waste Rules, 2016, which can be recycled/recovered/reused and only waste which has to be incinerated shall go to incineration and waste which can be used for land filling and cannot be recycled/reprocessed etc should go for that purpose, in order to reduce load on incineration and landfill site/environment.
- 8) The industry should comply with the Hazardous Waste (M, H & TM) Rules, 2016 and submit the Annual Returns as per Rule 5(1) & 2(2) of Hazardous Waste (M, H & TM) Rules, 2016 for the preceding year upto 15th March in terms by 30th June of every year.
- 9) An inspection book shall be prepared and made available to the Board's officers during their visit to the applicant.
- 10) The applicant shall make an application for renewal of the CCA at least 60 days before the date of the expiry of the CCA.
- 11) Industry shall strictly comply with the Water (PCCP) Act, 1974, Air (PSC) Act, 1980 and Environment Protection Act, 1986 and industry specific standards under EP Rules 1986 which are available on MPCB website (www.mpcb.gov.in).
- 12) The industry shall contribute an Environmental cell with qualified staff/personnel/agency to see the day to day compliance of consent conditions towards Environment Protection.
- 13) Separate drainage system shall be provided for collection of trade and sewage effluents, rain water and storm water. The drainage system shall be provided with arrangement for measuring the flow and it may occur than in the pipes/downstream of the terminal manholes. No effluents shall be allowed to discharge from other premises shall be allowed to mix with the effluents in the factory.
- 14) The applicant shall install a separate meter showing the consumption of energy for operation of domestic and industrial effluent treatment plants and air pollution control system. A register showing consumption of chemicals used for treatment shall be maintained.
- 15) Conditions for D.G. Set
 - a) Noise from the D.G. Set should be controlled by providing an acoustic enclosure or by treating room acoustically.
 - b) Industry should provide acoustic enclosure for control of noise. The acoustic enclosure/acoustic treatment of the room should be designed for minimum 25 dB (A) insertion loss or for meeting the ambient noise standards, whichever is on higher side. A suitable exhaust muffler with insertion loss of 25 dB (A) shall also be provided. The measurement of insertion loss will be done at different points at 0.5 meters from acoustic enclosure/room and then average.
- 16) Industry should make efforts to bring down noise level due to DG set, outside industrial premises, within ambient noise requirements by proper siting and control measures.
- 17) Installation of DG Set must be strictly in compliance with recommendations of DG Set manufacturer.
- 18) A proper routine and preventive maintenance procedure for DG set should be set and followed in demarcating with use.
- 19) D.G. Set shall be operated only in case of power failure.
- 20) The applicant should not create any nuisance in the surrounding area due to operation of D.G. Set.
- 21) The applicant shall comply with the notification of MoEF dated 17.03.2002 regarding noise limit for generator sets in with cities.
- 22) The industry should not cause any nuisance in surrounding area.
- 23) The industry shall take adequate measures for control of noise levels from its own premises within the premises in an to maintain ambient air quality standard in respect of noise to less than 70 dB (A) during day time and 70 dB (A) during night time. Day time is reckoned in between 6 a.m. and 6 p.m. and night time is reckoned between 10 p.m. and 6 a.m.
- 24) The applicant shall maintain good housekeeping.
- 25) The applicant shall submit a yearly statement by 30th September every year on available open plot area, number of trees surviving as on 31st March of the year and number of trees planted by September and so as not to cause any nuisance / pollution. The applicant shall take necessary permissions from local authorities for disposal of solid waste.
- 26) The applicant shall not change or alter the quantity, quality, rate of effluent, temperature on the mode of effluent/emissions or hazardous waste or control equipments provided for without previous written permission of the Board. The industry will not carry out any activity, for which this consent has not been granted without prior consent of the Board.
- 27) The industry shall ensure that fugitive emissions from the activity are controlled so as to maintain clean and safe environment in and around the factory premises.
- 28) The industry shall submit official e-mail address and any change will be duly informed to the MPCB.
- 29) The industry shall achieve the National Ambient Air Quality standards prescribed vide Government of India Notification dt. 16.11.2009 as amended.

-0000-

Ann IV : 04 of 04

Annexure V : 3rd Party Reports for Trade & Domestic Effluents (Old & New STP)

saenco

TEST REPORT

Company Name & Address: **Krishna Institute of Medical Sciences**
Tal. Karad, Dist. Satara

Kind Attention:

Order No. : SAE/16/14/01 Vii Sample Received Date: 14 May 2018
 Your Ref No. : Test Request Sampling Method: SAE/16/14/01
 Collected By : Customer Date of Analysis: 14 May 2018
 Sample Name: Water Sampling Location: STP Outlet Old
 Sample Qty : 2.5 L Packaging Material: Non Commercial Sterile Can
 Report No. : SAE/16/14/01-05 Date of Report: 24 May 2018

Sr. No	Parameters	Result	Unit	Standard Value	Analysis Method
1	pH	7.12	pH Unit	5.5 - 9.0	APHA 4500 H+ B
2	Total Dissolved Solids	790.00	mg/l	<2100	APHA 2540 C
3	Chemical Oxygen Demand	82.00	mg/l	<250	IS 3025 (Part 50): 2006
4	Biochemical Oxygen Demand (at 27±0.5°C for 3 days)	32.00	mg/l	<100	IS 3025 (Part 44): 2006
5	Oil & Grease	2.0	mg/l	<10	IS 3025 (Part 39): 2003

Remarks: **Not Applicable.**

Note:
 1. Test results pertain only to the sample tested.
 2. Standard Value: MPCC Consent.
 3. Parameters marked with * are not in MPCC Consent.
 4. SAE will advise the sample after 30/21/15 days from the date of Test Report.
 5. The content of Test Report shall be reproduced / used for advertising or legal use, in part or full, without written permission.

For S A Enco Private Limited
 Mrs. Nalini Talburkar - Quality Manager
 Authorized Signatory

END OF REPORT

saenco

TEST REPORT

Company Name & Address: **Krishna Institute of Medical Sciences**
Tal. Karad, Dist. Satara

Kind Attention:

Order No. : SAE/16/14/14 Viii Sample Received Date: 14 Jun 2018
 Your Ref No. : Test Request Sampling Method: SAE/16/14/14
 Collected By : Customer Date of Analysis: 14 Jun 2018
 Sample Name: Water Sampling Location: STP Outlet Old
 Sample Qty : 2.5 L Packaging Material: Non Commercial Sterile Can
 Report No. : SAE/16/14/14-02 Date of Report: 10 Jun 2018

Sr. No	Parameters	Result	Unit	Standard Value	Analysis Method
1	pH	6.39	pH Unit	5.5 - 9.0	APHA 4500 H+ B
2	Total Dissolved Solids	1360.0	mg/l	<2100	APHA 2540 C
3	Chemical Oxygen Demand	32.00	mg/l	<250	IS 3025 (Part 50): 2006
4	Biochemical Oxygen Demand (at 27±0.5°C for 3 days)	10.33	mg/l	<100	IS 3025 (Part 44): 2006
5	Oil & Grease	2.4	mg/l	<10	IS 3025 (Part 39): 2003

Remarks: **Not Applicable.**

Note:
 1. Test results pertain only to the sample tested.
 2. Standard Value: MPCC Consent.
 3. Parameters marked with * are not in MPCC Consent.
 4. SAE will advise the sample after 30/21/15 days from the date of Test Report.
 5. The content of Test Report shall be reproduced / used for advertising or legal use, in part or full, without written permission.

For S A Enco Private Limited
 Mrs. Nalini Talburkar - Quality Manager
 Authorized Signatory

END OF REPORT

saenco

TEST REPORT

Company Name & Address: **Krishna Institute of Medical Sciences**
Tal. Karad, Dist. Satara

Kind Attention:

Order No. : SAE/16/19/01 Vii Sample Received Date: 13 Jun 2018
 Your Ref No. : Test Request Sampling Method: SAE/16/19/01
 Collected By : Customer Date of Analysis: 14 Jun 2018
 Sample Name: Water Sampling Location: STP Outlet Old
 Sample Qty : 2.5 L Packaging Material: Non Commercial Sterile Can
 Report No. : SAE/16/19/01-17 Date of Report: 10 Jun 2018

Sr. No	Parameters	Result	Unit	Standard Value	Analysis Method
1	pH	7.32	pH Unit	5.5 - 9.0	APHA 4500 H+ B
2	Total Dissolved Solids	1340.0	mg/l	<2100	APHA 2540 C
3	Chemical Oxygen Demand	6.00	mg/l	<250	IS 3025 (Part 50): 2006
4	Biochemical Oxygen Demand (at 27±0.5°C for 3 days)	3.00	mg/l	<100	IS 3025 (Part 44): 2006
5	Oil & Grease	0.1	mg/l	<10	IS 3025 (Part 39): 2003

Remarks: **Not Applicable.**

Note:
 1. Test results pertain only to the sample tested.
 2. Standard Value: MPCC Consent.
 3. Parameters marked with * are not in MPCC Consent.
 4. SAE will advise the sample after 30/21/15 days from the date of Test Report.
 5. The content of Test Report shall be reproduced / used for advertising or legal use, in part or full, without written permission.

For S A Enco Private Limited
 Mrs. Nalini Talburkar - Quality Manager
 Authorized Signatory

END OF REPORT

saenco

TEST REPORT

Company Name & Address: **Krishna Institute of Medical Sciences**
Tal. Karad, Dist. Satara

Kind Attention:

Order No. : SAE/16/19/02 Viii Sample Received Date: 18 May 2018
 Your Ref No. : Test Request Sampling Method: SAE/16/19/02
 Collected By : Customer Date of Analysis: 19 May 2018
 Sample Name: Water Sampling Location: STP Outlet New
 Sample Qty : 2.5 L Packaging Material: Non Commercial Sterile Can
 Report No. : SAE/16/19/02-14 Date of Report: 24 May 2018

Sr. No	Parameters	Result	Unit	Standard Value	Analysis Method
1	pH	7.65	pH Unit	5.5 - 9.0	APHA 4500 H+ B
2	Total Dissolved Solids	720.00	mg/l	<2100	APHA 2540 C
3	Chemical Oxygen Demand	48.00	mg/l	<250	IS 3025 (Part 50): 2006
4	Biochemical Oxygen Demand (at 27±0.5°C for 3 days)	14.00	mg/l	<100	IS 3025 (Part 44): 2006
5	Oil & Grease	1.0	mg/l	<10	IS 3025 (Part 39): 2003

Remarks: **Results are within MPCC Consent Limits.**

Note:
 1. Test results pertain only to the sample tested.
 2. Standard Value: MPCC Consent.
 3. Parameters marked with * are not in MPCC Consent.
 4. SAE will advise the sample after 30/21/15 days from the date of Test Report.
 5. The content of Test Report shall be reproduced / used for advertising or legal use, in part or full, without written permission.

For S A Enco Private Limited
 Mrs. Nalini Talburkar - Quality Manager
 Authorized Signatory

END OF REPORT

saenco

TEST REPORT

Company Name & Address: **Krishna Institute of Medical Sciences**
Tal. Karad, Dist. Satara

Kind Attention:

Order No. : SAE/16/19/14 Vii Sample Received Date: 13 Jun 2018
 Your Ref No. : Test Request Sampling Method: SAE/16/19/14
 Collected By : Customer Date of Analysis: 14 Jun 2018
 Sample Name: Water Sampling Location: STP Outlet New
 Sample Qty : 2.5 L Packaging Material: Non Commercial Sterile Can
 Report No. : SAE/16/19/14-01 Date of Report: 10 Jun 2018

Sr. No	Parameters	Result	Unit	Standard Value	Analysis Method
1	pH	7.53	pH Unit	5.5 - 9.0	APHA 4500 H+ B
2	Total Dissolved Solids	606.00	mg/l	<2100	APHA 2540 C
3	Chemical Oxygen Demand	20.00	mg/l	<250	IS 3025 (Part 50): 2006
4	Biochemical Oxygen Demand (at 27±0.5°C for 3 days)	7.10	mg/l	<100	IS 3025 (Part 44): 2006
5	Oil & Grease	2.0	mg/l	<10	IS 3025 (Part 39): 2003

Remarks: **Results are within MPCC Consent Limits.**

Note:
 1. Test results pertain only to the sample tested.
 2. Standard Value: MPCC Consent.
 3. Parameters marked with * are not in MPCC Consent.
 4. SAE will advise the sample after 30/21/15 days from the date of Test Report.
 5. The content of Test Report shall be reproduced / used for advertising or legal use, in part or full, without written permission.

For S A Enco Private Limited
 Mrs. Nalini Talburkar - Quality Manager
 Authorized Signatory

END OF REPORT

saenco

TEST REPORT

Company Name & Address: **Krishna Institute of Medical Sciences**
Tal. Karad, Dist. Satara

Kind Attention:

Order No. : SAE/16/19/15 Viii Sample Received Date: 13 Jun 2018
 Your Ref No. : Test Request Sampling Method: SAE/16/19/15
 Collected By : Customer Date of Analysis: 14 Jun 2018
 Sample Name: Water Sampling Location: STP Outlet New
 Sample Qty : 2.5 L Packaging Material: Non Commercial Sterile Can
 Report No. : SAE/16/19/15-16 Date of Report: 10 Jun 2018

Sr. No	Parameters	Result	Unit	Standard Value	Analysis Method
1	pH	7.29	pH Unit	5.5 - 9.0	APHA 4500 H+ B
2	Total Dissolved Solids	1430.00	mg/l	<2100	APHA 2540 C
3	Chemical Oxygen Demand	12.00	mg/l	<250	IS 3025 (Part 50): 2006
4	Biochemical Oxygen Demand (at 27±0.5°C for 3 days)	6.00	mg/l	<100	IS 3025 (Part 44): 2006
5	Oil & Grease	0.2	mg/l	<10	IS 3025 (Part 39): 2003

Remarks: **Results are within MPCC Consent Limits.**

Note:
 1. Test results pertain only to the sample tested.
 2. Standard Value: MPCC Consent.
 3. Parameters marked with * are not in MPCC Consent.
 4. SAE will advise the sample after 30/21/15 days from the date of Test Report.
 5. The content of Test Report shall be reproduced / used for advertising or legal use, in part or full, without written permission.

For S A Enco Private Limited
 Mrs. Nalini Talburkar - Quality Manager
 Authorized Signatory

END OF REPORT

Ann V : 01 of 01

Annexure VII : Certificate for Work done for Rain Water Harvesting & Storm Water Management

KIMSDU, Karad. RAIN WATER HARVESTING



KRISHNA INSTITUTE OF MEDICAL SCIENCES
"DEEMED TO BE UNIVERSITY",
S. NO. – 144-B, MALKAPUR, TAL – KARAD, DIST – SATARA.

KRISHNA CHARITABLE TRUST,
S. NO. – 144-B, MALKAPUR, TAL – KARAD, DIST – SATARA.

PROJECT NAME – RAIN WATER HARVESTING (2018)-BY CIVIL DEPARTMENT
KIMSDU.DEPARTMENT NAME – CIVIL-MAINTENANCE DEPT.

Sr. No.	Building Name	Terrace area sq.m.	Water collection lac lit/year	Near Bore
1	BDS hostel	640	4.00	Bore no. 2
2	Ward no. 14,19	766	4.78	Bore no. 3



JAGTAP.S.V.
CIVIL INCHARGE
K.I.M.S.D.U., KARAD

Annexure VIII : Documents related to Protocol, Check points, recruitment of staff for Housekeeping

**KRISHNA INSTITUTE OF MEDICAL SCIENCES
"DEEMED TO BE" UNIVERSITY,
KARAD.**

JOB PROFILE OF HOUSEKEEPING SUPERVISOR. (Night Shift)

- 1) Housekeeping Supervisor has to wear proper uniform, staff ID card and shoes while on duty.
- 2) Has to take attendance at the start of each shift.
- 3) Handle staff grooming.
- 4) Ensure staff management is handled properly and to co-ordinate nursing staff while on duty.
- 5) To ensure that housekeeping staffs wear the correct uniform and staff ID card all times while on duty.
- 7) Support administrative and management tasks.
- 8) Ensure that the housekeeping staff is working in accordance to the hospital's rules.
- 9) Make sure that the appearance of the hospital is clean and tidy.
- 10) Maintain constant awareness of the cleanliness of the hospital.
- 11) Responsible for maintaining inventory of cleaning supplies and providing cleaning material through Housekeeping Dept. Store.
- 12) Oversee Housekeeping staff to ensure that they are properly and safely attired.
- 13) Monitor check and maintain standards of cleanliness within all areas of the hospital on every shift base.
- 14) To audit self check cleaning sheets daily.
- 15) To maintain a professional and helpful attitude while on duty towards patient.
- 16) Support all concern departments.
- 17) Ensure every incident report should be reported in written.
- 18) Class IV Leave Management.
- 19) Incident reporting to AR, IWO and AO on a daily Basis.
- 20) Handling disciplinary issues.
- 21) Ensuring compliance to ISO, NABH, NABL and NAAC audits and documentation.
- 22) Monthly training of all class IV staff.
- 23) Daily briefing and de-briefing of class IV staff.
- 24) Handling nursing requests to the best possible resource availability.
- 25) Exception handling to be done in a fair and just manner.
- 26) Maintaining log book for clear and timely communicate with AO, HSK supervisor and clerk.
- 27) Ensuring materials availability in housekeeping stores.
- 28) Reporting and maintenance or repaired to housekeeping equipments.
- 29) Weekly requisitioning of required material from stores.
- 30) Ensuring timely shifting of man and material during inspections.

- 31) Maintaining the housekeeping standards in the entire hospital.
- 32) Ensuring strict adherence to the code of conduct from all subordinates.
- 33) Shifting of class IV employees as the dynamic at work.
- 34) Handling and resolving complaints related to housekeeping.
- 35) Handling and resolving behavioral complaint of housekeeping at all times.
- 36) Monthly housekeeping NABH adherence report to be submitted to AO.
- 37) Show cause notice to be issued for misbehavior and disciplinary issues.
- 38) Performance monitoring of all subordinate staff.
- 39) Compliance with requests from MD, MA, AR and AO office.
- 40) Ensuring adherence to daily, week and monthly reporting.
- 41) On duty Supervisor cannot leave hospital premises without prior permission of HSK HOD, AO and Assistant Registrar.
- 42) Night Supervisor has to take round with Security Supervisor and Night Nursing Supervisor.
- 43) He/ She has to ensure no class IV employees sleep during night shift.

Mr. Dhananjay D. Patil.
Sanitary Inspector.

Krishna Institute of Medical Sciences "Deemed to Be University", Karad.										
Particular	General		Morning		Evening		Night		Total	
	Male	Female	Male	Female	Male	Female	Male	Female	Male	Female
All Departments & OPD	134		0		0		0		134	
	77	57	0	0	0	0	0	0	77	57
	Male	Female	Male	Female	Male	Female	Male	Female	Male	Female
All Colleges & Hostels	257		0		25		4		286	
	207	50	0	0	5	20	1	3	213	73
	Male	Female	Male	Female	Male	Female	Male	Female	Male	Female
Patient Care	0		95		80		71		246	
	0	0	42	53	53	27	45	26	160	89
	Male	Female	Male	Female	Male	Female	Male	Female	Male	Female
Supervisors	4		2		1		1		8	
	4	0	2	0	1	0	1	0	8	0
	Male	Female	Male	Female	Male	Female	Male	Female	Male	Female
Grand Total	283		82		64		33		59	
	283	82	64	33	59	47	47	29	453	191
	Male	Female	Male	Female	Male	Female	Male	Female	Male	Female
	365		97		106		76		644	

Ann VIII : 01 of 02

**KRISHNA INSTITUTE OF MEDICAL SCIENCES
"DEEMED TO BE" UNIVERSITY,
KARAD.**

JOB PROFILE OF HOUSEKEEPING SUPERVISOR (Extempore Shift)

- 1) Housekeeping supervisor has to wear proper uniform, staff ID card and shoes while on duty
- 2) Has to take attendance at the start of each shift
- 3) Handle staff grooming.
- 4) Involves staff management in handling properly and to co-ordinate matting staff while on duty.
- 5) To ensure that housekeeping staffs wear the correct uniform and staff ID card all times while on duty.
- 6) Support administrative and management tasks
- 7) Ensure that the housekeeping staff is working in accordance to the hospital's rules
- 8) Make sure that the appearance of the hospital is clean and tidy
- 9) Maintain constant awareness of the cleanliness of the hospital
- 10) Responsible for maintaining inventory of cleaning supplies and providing cleaning material through housekeeping Dept. Store
- 11) Oversee Housekeeping staff to ensure that they are properly and safely attired
- 12) Monitor check and maintain standards of cleanliness within all areas of the hospital on every shift basis
- 13) To audit self check cleaning sheets daily
- 14) To maintain a professional and helpful attitude while on duty towards patients.
- 15) Support all clinical departments
- 16) Ensure every incident report should be reported in written
- 17) Class V Leave Management
- 18) Incident reporting to AR, ESCO and AD on a daily basis
- 19) Handling disciplinary issues
- 20) Ensuring compliance to ISO, NABL, NABL and NAAC audits and documentation
- 21) Monthly training of all class IV staff
- 22) Daily briefing on the briefing of class IV staff
- 23) Handling nursing requests to the best possible resource availability
- 24) Ensuring material's availability in housekeeping stores
- 25) Reporting and maintenance or repaired to housekeeping equipments
- 26) Reporting and maintenance or repaired to housekeeping equipments
- 27) Inventory requisitioning of required materials from stores
- 28) Ensuring timely shifting of mats and material during inspections
- 29) Maintaining the housekeeping standards in the entire hospital.
- 30) Encouraging strict adherence to the code of conduct from all subordinates.
- 31) Shifting of class IV employees as the dynamic at work.

- 32) Handling and resolving complaints related to housekeeping
- 33) Monthly housekeeping audit and compliance report from subordinates to AD
- 34) Submitting to the AD for maintenance and disciplinary issues
- 35) Maintaining the inventory of all housekeeping staff
- 36) Maintaining the inventory of all housekeeping staff
- 37) Maintaining the inventory of all housekeeping staff
- 38) Maintaining the inventory of all housekeeping staff
- 39) Maintaining the inventory of all housekeeping staff
- 40) Maintaining the inventory of all housekeeping staff
- 41) Maintaining the inventory of all housekeeping staff
- 42) Maintaining the inventory of all housekeeping staff
- 43) Maintaining the inventory of all housekeeping staff
- 44) Maintaining the inventory of all housekeeping staff
- 45) Maintaining the inventory of all housekeeping staff
- 46) Maintaining the inventory of all housekeeping staff
- 47) Maintaining the inventory of all housekeeping staff
- 48) Maintaining the inventory of all housekeeping staff
- 49) Maintaining the inventory of all housekeeping staff
- 50) Maintaining the inventory of all housekeeping staff
- 51) Maintaining the inventory of all housekeeping staff
- 52) Maintaining the inventory of all housekeeping staff
- 53) Maintaining the inventory of all housekeeping staff
- 54) Maintaining the inventory of all housekeeping staff
- 55) Maintaining the inventory of all housekeeping staff
- 56) Maintaining the inventory of all housekeeping staff
- 57) Maintaining the inventory of all housekeeping staff
- 58) Maintaining the inventory of all housekeeping staff
- 59) Maintaining the inventory of all housekeeping staff
- 60) Maintaining the inventory of all housekeeping staff
- 61) Maintaining the inventory of all housekeeping staff
- 62) Maintaining the inventory of all housekeeping staff
- 63) Maintaining the inventory of all housekeeping staff
- 64) Maintaining the inventory of all housekeeping staff
- 65) Maintaining the inventory of all housekeeping staff
- 66) Maintaining the inventory of all housekeeping staff
- 67) Maintaining the inventory of all housekeeping staff
- 68) Maintaining the inventory of all housekeeping staff
- 69) Maintaining the inventory of all housekeeping staff
- 70) Maintaining the inventory of all housekeeping staff
- 71) Maintaining the inventory of all housekeeping staff
- 72) Maintaining the inventory of all housekeeping staff
- 73) Maintaining the inventory of all housekeeping staff
- 74) Maintaining the inventory of all housekeeping staff
- 75) Maintaining the inventory of all housekeeping staff
- 76) Maintaining the inventory of all housekeeping staff
- 77) Maintaining the inventory of all housekeeping staff
- 78) Maintaining the inventory of all housekeeping staff
- 79) Maintaining the inventory of all housekeeping staff
- 80) Maintaining the inventory of all housekeeping staff
- 81) Maintaining the inventory of all housekeeping staff
- 82) Maintaining the inventory of all housekeeping staff
- 83) Maintaining the inventory of all housekeeping staff
- 84) Maintaining the inventory of all housekeeping staff
- 85) Maintaining the inventory of all housekeeping staff
- 86) Maintaining the inventory of all housekeeping staff
- 87) Maintaining the inventory of all housekeeping staff
- 88) Maintaining the inventory of all housekeeping staff
- 89) Maintaining the inventory of all housekeeping staff
- 90) Maintaining the inventory of all housekeeping staff
- 91) Maintaining the inventory of all housekeeping staff
- 92) Maintaining the inventory of all housekeeping staff
- 93) Maintaining the inventory of all housekeeping staff
- 94) Maintaining the inventory of all housekeeping staff
- 95) Maintaining the inventory of all housekeeping staff
- 96) Maintaining the inventory of all housekeeping staff
- 97) Maintaining the inventory of all housekeeping staff
- 98) Maintaining the inventory of all housekeeping staff
- 99) Maintaining the inventory of all housekeeping staff
- 100) Maintaining the inventory of all housekeeping staff

Mr. Jyotsnagar D. P. Patil,
Secretary, Karad.

2018

	KIMS DU	Doc Number	KIMS DU/MAIN/FORM
	Name Of Document	Water Tank Cleaning Calendar (2018)	
	Name Of the Process/ Area	CIVIL / MAINTENANCE	

Water Tank No.	Name of water tank	Date	Cleaned by	Checked by	Civil Sup. Sign
1	Makes water tank	8/6/2018	राजेश / राजेश / राजेश	राजेश / राजेश / राजेश	
2	L.H.R. Hostel I	26/6/2018	राजेश / राजेश / राजेश	राजेश / राजेश / राजेश	
3	R.D.S. Hostel-48	25/6/2018	राजेश / राजेश / राजेश	राजेश / राजेश / राजेश	
4	NRU Hostel	26/6/2018	राजेश / राजेश / राजेश	राजेश / राजेश / राजेश	
5	B.Sc. Nursing IV	12/6/2018	राजेश / राजेश / राजेश	राजेश / राजेश / राजेश	
6	B.Sc. Nursing V	13/6/2018	राजेश / राजेश / राजेश	राजेश / राजेश / राजेश	
7	B.Sc. Nursing VI	13/6/2018	राजेश / राजेश / राजेश	राजेश / राजेश / राजेश	
8	New NRI Hostel-07	11/6/2018	राजेश / राजेश / राजेश	राजेश / राजेश / राजेश	
9	NEW Ladies Hostel	11/6/2018	राजेश / राजेश / राजेश	राजेश / राजेश / राजेश	
10	Old Ladies Hostel	11/6/2018	राजेश / राजेश / राजेश	राजेश / राजेश / राजेश	
11	New Guest House	13/6/2018	राजेश / राजेश / राजेश	राजेश / राजेश / राजेश	
12	Old Guest House	22/6/2018	राजेश / राजेश / राजेश	राजेश / राजेश / राजेश	
13	A-Type Quarter	13/6/2018	राजेश / राजेश / राजेश	राजेश / राजेश / राजेश	
14	B-Type Quarter	14/6/2018	राजेश / राजेश / राजेश	राजेश / राजेश / राजेश	
15	B-Wing 2 Quarter	13/6/2018	राजेश / राजेश / राजेश	राजेश / राजेश / राजेश	
16	D-TYPE Quarter	13/6/2018	राजेश / राजेश / राजेश	राजेश / राजेश / राजेश	
17	E-TYPE Quarter	20/6/2018	राजेश / राजेश / राजेश	राजेश / राजेश / राजेश	
18	Physiotherapy College	25/6/2018	राजेश / राजेश / राजेश	राजेश / राजेश / राजेश	
19	Dental College	26/6/2018	राजेश / राजेश / राजेश	राजेश / राजेश / राजेश	
20	Nursing Hostel-02	11/6/2018	राजेश / राजेश / राजेश	राजेश / राजेश / राजेश	
21	Nursing College	23/6/2018	राजेश / राजेश / राजेश	राजेश / राजेश / राजेश	
22	Gym	30/6/2018	राजेश / राजेश / राजेश	राजेश / राजेश / राजेश	
23	Cafeteria	11/6/2018	राजेश / राजेश / राजेश	राजेश / राजेश / राजेश	
24	Medical College	13/6/2018	राजेश / राजेश / राजेश	राजेश / राजेश / राजेश	
25	WARD NO.7	13/6/2018	राजेश / राजेश / राजेश	राजेश / राजेश / राजेश	
26	WARD NO.8	11/6/2018	राजेश / राजेश / राजेश	राजेश / राजेश / राजेश	
27	WARD NO.9	11/6/2018	राजेश / राजेश / राजेश	राजेश / राजेश / राजेश	
28	WARD NO.11	23/6/2018	राजेश / राजेश / राजेश	राजेश / राजेश / राजेश	
29	WARD NO.13	23/6/2018	राजेश / राजेश / राजेश	राजेश / राजेश / राजेश	
30	WARD NO.18	23/6/2018	राजेश / राजेश / राजेश	राजेश / राजेश / राजेश	
31	WARD NO.19	23/6/2018	राजेश / राजेश / राजेश	राजेश / राजेश / राजेश	
32	WARD NO.28	23/6/2018	राजेश / राजेश / राजेश	राजेश / राजेश / राजेश	
33	New P.H. Room Ward 51	26/6/2018	राजेश / राजेश / राजेश	राजेश / राजेश / राजेश	
34	UNIVERSITY OFFICE	14/6/2018	राजेश / राजेश / राजेश	राजेश / राजेश / राजेश	
35	VIP-ICU	13/6/2018	राजेश / राजेश / राजेश	राजेश / राजेश / राजेश	
36	Green Dept. (Security changing room)	02/6/2018	राजेश / राजेश / राजेश	राजेश / राजेश / राजेश	
37	Power House	22/6/2018	राजेश / राजेश / राजेश	राजेश / राजेश / राजेश	
38	Dept. Office (K.Rdy Ter.)	23/6/2018	राजेश / राजेश / राजेश	राजेश / राजेश / राजेश	

DAILY REPORT

Sl. No.	Name of the Staff	Shift	Attendance	Remarks
1
2
3
4
5
6
7
8
9
10
11
12
13
14
15
16
17
18
19
20
21
22
23
24
25
26
27
28
29
30
31
32
33
34
35
36
37
38
39
40
41
42
43
44
45
46
47
48
49
50

Annexure IX: Sample Documentation maintained for BMW

Dept. : Biomedical Waste Management

Record : Monthly Biomedical Waste Incinerated

Month : May 2018

Type Of Bio Medical Waste	Kg/ month
Human Anatomical Waste (Cat 1)	328 Kg
Microbiology & Biotechnology Waste (Cat 3)	314 Kg
Soiled Waste (Cat 6)	2049 Kg
Total	2633 Kg

Dept. : Biomedical Waste Management

Record : Monthly Biomedical Waste Incinerated

Month : June 2018

Type Of Bio Medical Waste	Kg/ month
Human Anatomical Waste (Cat 1)	300 Kg
Microbiology & Biotechnology Waste (Cat 3)	335 Kg
Soiled Waste (Cat 6)	2280 Kg
Total	2915 Kg

Ann IX : 01 of 03

Dept. : Biomedical Waste Management
Record : Monthly Biomedical Waste Incinerated
Month : July 2018

Type Of Bio Medical Waste	Kg/ month
Human Anatomical Waste (Cat 1)	348 Kg
Microbiology & Biotechnology Waste (Cat 3)	305 Kg
Soiled Waste (Cat 6)	2772 Kg
Total	3425 Kg

Dept. : Biomedical Waste Management
Record : Disinfected Biomedical Waste
Month : May 2018

Type of Biomedical Waste	Kg/ month
Disinfected Plastic Bottles	573 Kg
Disinfected Gloves	813 Kg
Disinfected I.V. Sets	701 Kg
Disinfected Glass Bottles	848 Kg
Disinfected Syringes	301 Kg
Total	3236 Kg

Ann IX : 02 of 03

Dept. : Biomedical Waste Management

Record : Disinfected Biomedical Waste

Month : June 2018

Type of Biomedical Waste	Kg/ month
Disinfected Plastic Bottles	514 Kg
Disinfected Gloves	767 Kg
Disinfected I.V. Sets	631 Kg
Disinfected Glass Bottles	782 Kg
Needles	51 Kg
Disinfected Syringes	291 Kg
Total	3036 Kg

Dept. : Biomedical Waste Management

Record : Disinfected Biomedical Waste

Month : July 2018

Type of Biomedical Waste	Kg/ month
Disinfected Plastic Bottles	747 Kg
Disinfected Gloves	817 Kg
Disinfected I.V. Sets	624 Kg
Disinfected Glass Bottles	766 Kg
Needles	72 Kg
Disinfected Syringes	286 Kg
Total	3312 Kg

Ann IX : 03 of 03

Annexure X : The Disposal of E-Waste is documented by the Concerned Department

IMG20201010105756 #9

Old Out of Use Material in Power House

Power House - Electrical Material list 11/07/2019				
Sr no	Pannel Description	Make	Unit	Qty
	250 KVA Transformer			
1	Sr. No. UT - 81FD-070-703	Kirloskar	Nos	1
2	Sr. No. 81FD-070/121	Kirloskar	Nos	1
3	Sr. PE 2K 1299	Power Engineers	Nos	1

S.C. Paril

[Signature]

Power House

[Signature]

Store Dept

[Signature]

Security Dept

All material checked & sent to further disposal process.

[Signature]

ELECTRICAL ENGINEER
KIMSDU, KARAD

[Signature]

Electrical Department
KIMSDU, KARAD

[Signature]

Annexure XI : Report showing unit Consumption from Electricity sourced from MSEDCL & from Own Solar Power Grid

Dept. : Power House (Electricity consumption sourced from MSEDCL)

Year : 2018

MSEDCL		
Year 2018		
Sr. no.	Month	MSEDCL Unit Consumed
1	May-18	393323
2	Jun-18	332145
3	Jul-18	314145

Dept. : Power House (Electricity consumption sourced from 'Solar Power Grid')

Year : 2018

Solar Power Grid		
Year 2018		
Sr. no.	Month	Unit Consumed
1	May-18	393323
2	Jun-18	332145
3	Jul-18	314145

Annexure XII : Fire Mock Drills & Training

Dept. : Security Dept. (Emergency Code Red (Fire) Training)

Date : 28/05/2018

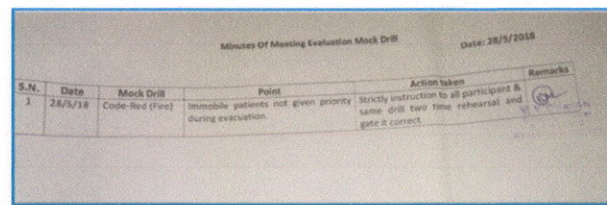
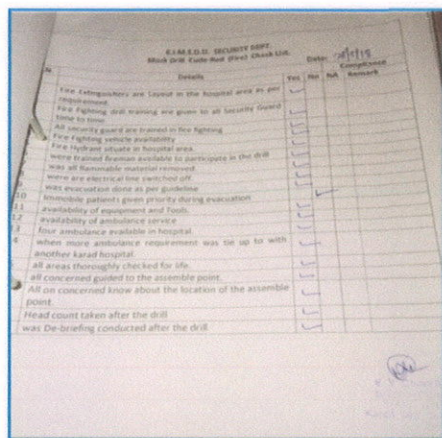
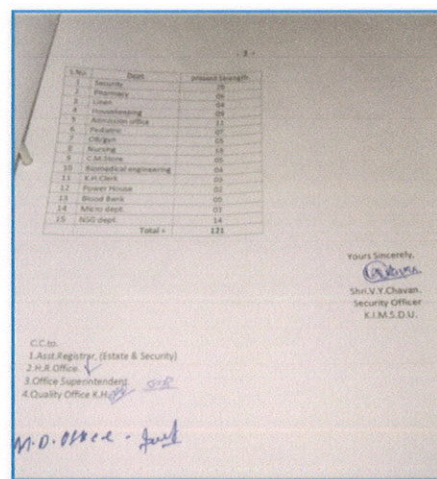
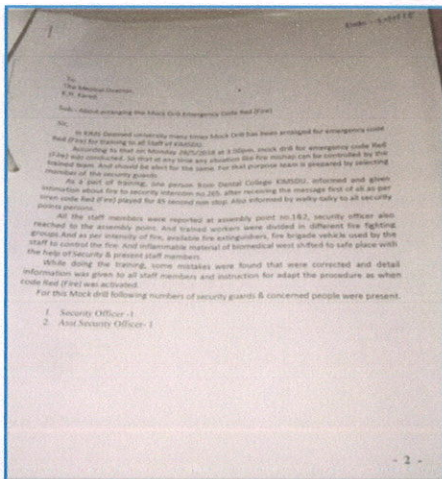
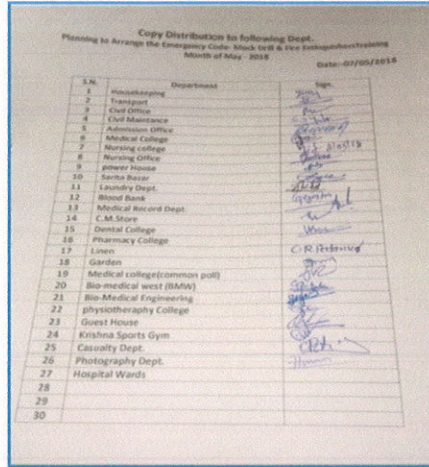
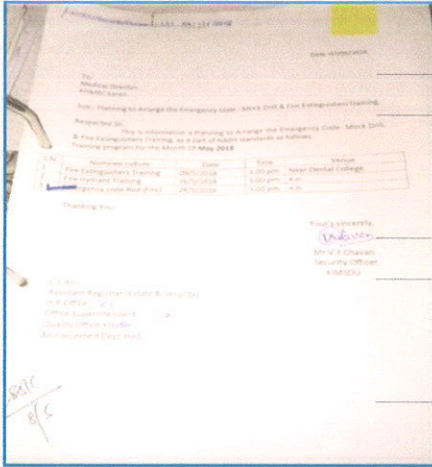

Ann XII : 01 of 06

K.I.M.S.D.U. SECURITY DEPT.
Mock Drill Code-Red (Fire) Briefing Report Date-28/5/2018

S.N.	Details
1	At the Assembly point following all person and given instruction to all about incident, place, & current situation.
2	Man power distributes in various groups.
3	Each group has distributes their responsibility in code-red (Fire).
4	Every participant will be use safety measures.
5	Evacuate the patient safety from Ward & pon them on safe place.

K.I.M.S.D.U. SECURITY DEPT.
Mock Drill Code-Red (Fire) De-Briefing Report Date-28/5/2018

S.N.	Details
1	Immobile patient not given priority during evacuation.
2	Every participant has done their given responsibility.
3	Every participant done hard work & use commonsense during code-red(fire) activation.
4	Over all Code-red(fire) drill was good in future also will do the very good job.

V. Y. Chavhan
Security Officer
K.I.M.S.D.U.
Karnal Road, Solapur

A minute by minute audit sheet of code-Red (Fire) Mock Drill.

28/5/2018	Date of code Activation
15.00 hrs.	Code-Red(fire) activation time
15.01 hrs.	By walky-talky passed the information to all security guard those who are on duty about code red(fire) mock drill
15.02 hrs.	Blow the Siren for 45 second (code use for fire)
15.04 hrs.	Security guard has reported at main gate during this time fire fighter vehicle and ambulance also reported at assembly point no.1 near main gate.
15.06 hrs.	In detail briefed to present security guard about present situation of incident & any fire fighting material.
15.07 hrs.	Same information given to assembly no.2 to present hospital staff.
15.08 hrs.	Assembly no.1 & 2 point person falling by at no.2 assembly point & distributes the train person, in various different parties and gave them task.
15.15 hrs.	All distributes fire fighting party reached the incident place.
15.20 hrs.	All Fire fighting party they started their task and they complete fire task within the time.
15.30 hrs.	After completion of mock drill
15.40 hrs.	All participant staff has falling for debriefings of mock drill.

KIMSDU
Name of the Director
Name of the Process/Unit

Date: 28/5/18
Training Topic: Emergency Code Red (Fire)
Training Hours: 15.00 to 15.40

Family: V. Y. Chavhan (S.O.)
Dept: Security
Venue: Main Dental Calm

S.No.	Name of Participant	Signature of Participant	Training Feedback	Effectiveness Assessment	Remarks if Any
1	Mr. Prabhakar A. Patil				
2	Mr. Prabhakar B. Patil				
3	Mr. Prabhakar C. Patil				
4	Mr. Prabhakar D. Patil				
5	Mr. Prabhakar E. Patil				
6	Mr. Prabhakar F. Patil				
7	Mr. Prabhakar G. Patil				
8	Mr. Prabhakar H. Patil				
9	Mr. Prabhakar I. Patil				
10	Mr. Prabhakar J. Patil				

Remarks: Grade A: Training Conducted effectively
Grade B: Training not conducted effectively
Grade C: Training Conducted for sufficient duration
Grade D: Training Conducted for insufficient duration
Grade E: All topics covered
Grade F: Training inadequate

KIMSDU
Name of the Director
Name of the Process/Unit

Date: 28/5/18
Training Topic: Emergency Code Red (Fire)
Training Hours: 15.00 to 15.40

Family: V. Y. Chavhan (S.O.)
Dept: Security
Venue: Main Dental Calm

S.No.	Name of Participant	Signature of Participant	Training Feedback	Effectiveness Assessment	Remarks if Any
1	Mr. Prabhakar A. Patil				
2	Mr. Prabhakar B. Patil				
3	Mr. Prabhakar C. Patil				
4	Mr. Prabhakar D. Patil				
5	Mr. Prabhakar E. Patil				
6	Mr. Prabhakar F. Patil				
7	Mr. Prabhakar G. Patil				
8	Mr. Prabhakar H. Patil				
9	Mr. Prabhakar I. Patil				
10	Mr. Prabhakar J. Patil				

Remarks: Grade A: Training Conducted effectively
Grade B: Training not conducted effectively
Grade C: Training Conducted for sufficient duration
Grade D: Training Conducted for insufficient duration
Grade E: All topics covered
Grade F: Training inadequate

KIMSDU
Name of the Director
Name of the Process/Unit

Date: 28/5/18
Training Topic: Emergency Code Red (Fire)
Training Hours: 15.00 to 15.40

Family: V. Y. Chavhan (S.O.)
Dept: Security
Venue: Main Dental Calm

S.No.	Name of Participant	Signature of Participant	Training Feedback	Effectiveness Assessment	Remarks if Any
1	Mr. Prabhakar A. Patil				
2	Mr. Prabhakar B. Patil				
3	Mr. Prabhakar C. Patil				
4	Mr. Prabhakar D. Patil				
5	Mr. Prabhakar E. Patil				
6	Mr. Prabhakar F. Patil				
7	Mr. Prabhakar G. Patil				
8	Mr. Prabhakar H. Patil				
9	Mr. Prabhakar I. Patil				
10	Mr. Prabhakar J. Patil				

Remarks: Grade A: Training Conducted effectively
Grade B: Training not conducted effectively
Grade C: Training Conducted for sufficient duration
Grade D: Training Conducted for insufficient duration
Grade E: All topics covered
Grade F: Training inadequate

KIMSDU
Name of the Director
Name of the Process/Unit

Date: 28/5/18
Training Topic: Emergency Code Red (Fire)
Training Hours: 15.00 to 15.40

Family: V. Y. Chavhan (S.O.)
Dept: Security
Venue: Main Dental Calm

S.No.	Name of Participant	Signature of Participant	Training Feedback	Effectiveness Assessment	Remarks if Any
1	Mr. Prabhakar A. Patil				
2	Mr. Prabhakar B. Patil				
3	Mr. Prabhakar C. Patil				
4	Mr. Prabhakar D. Patil				
5	Mr. Prabhakar E. Patil				
6	Mr. Prabhakar F. Patil				
7	Mr. Prabhakar G. Patil				
8	Mr. Prabhakar H. Patil				
9	Mr. Prabhakar I. Patil				
10	Mr. Prabhakar J. Patil				

Remarks: Grade A: Training Conducted effectively
Grade B: Training not conducted effectively
Grade C: Training Conducted for sufficient duration
Grade D: Training Conducted for insufficient duration
Grade E: All topics covered
Grade F: Training inadequate

KIMSDU		Doc Number	KIMSDU/SEC/P/04	TRAINING RECORD	
Name of the Document		Name of the Province/Area			
Date: 28/11/2018					
Training Topic: Emergency Code Red (Fire)					
Faculty: V Y Chavan (S.O)					
Base: Govt Dental College					
Venue: Govt Dental College					
No	Name of Participant	Signature of Participant	Training Feedback	Effectiveness Assessment	Remarks if Any
1	Mr. Anil D. Patil	<i>[Signature]</i>			
2	Mr. Prakash Patil	<i>[Signature]</i>			
3	Mr. Anand Patil	<i>[Signature]</i>			
4					
5					
6					
7					
8					
9					
10					
11					
12					
13					
14					

Remarks: Grade A: Training Conducted effectively
 Grade B: Training not conducted effectively
 Grade C: Training Conducted for sufficient duration
 Grade D: Training Conducted for insufficient duration
 Grade E: All topics covered
 Grade F: Training inadequate

KIMSDU		Doc Number	KIMSDU/SEC/P/04	TRAINING RECORD	
Name of the Document		Name of the Province/Area			
Date: 28/11/18					
Training Topic: Emergency Code Red (Fire)					
Faculty: V Y Chavan (S.O)					
Base: Govt Dental College					
Venue: Govt Dental College					
No	Name of Participant	Signature of Participant	Training Feedback	Effectiveness Assessment	Remarks if Any
1	Mr. Anil D. Patil	<i>[Signature]</i>			
2	Mr. Prakash Patil	<i>[Signature]</i>			
3	Mr. Anand Patil	<i>[Signature]</i>			
4					
5					
6					
7					
8					
9					
10					
11					
12					
13					
14					

Remarks: Grade A: Training Conducted effectively
 Grade B: Training not conducted effectively
 Grade C: Training Conducted for sufficient duration
 Grade D: Training Conducted for insufficient duration
 Grade E: All topics covered
 Grade F: Training inadequate



Ann XII : 04 of 06

Dept. : Security Dept. (Fire Hydrant Mock drill)

Date : 20/07/2018

Date: 20/07/2018

To,
Medical Director,
KIMSDU Karad.

Subj: Planning to Arrange the Emergency Code - Mock Drill & Fire Hydrants Training.

Respected Sir,
This is information planning to arrange the Emergency Code - Mock Drill & Fire Hydrants Training as a part of NAHR standard as follows.

S.N.	Nominee culture	Date	Time	Venue
1	Emergency Code-Red (Fire)	12/07/2018	3.00 pm.	K.H.
2	Fire Hydrants Training.	20/07/2018	3.00 pm.	K.H.
3	Emergency Code - Violet	24/07/2018	3.00 pm.	K.H.

Thanking You.

Your's sincerely,
(Signature)
Mr. V. V. Chavan,
Security Officer
KIMSDU

C.C.to:-
Assistant Registrar (Estate & Security)
H.R. Office. ✓
Office Superintendent. ✓
Quality Office, K.H. ✓
All concerned Dept. Med.

Received
(Signature)
16-7-18

Planning to Arrange the Emergency Code - Mock Drill & Fire Hydrants Training
Month of July - 2018
Date: 20/07/2018

S.N.	Department	Sign.
1	Housekeeping	
2	Transport	
3	Civil Office	
4	Civil Maintenance	
5	Admission Office	
6	Medical College	
7	Nursing college	
8	Nursing Office	
9	Power House	
10	Sarita Bazar	
11	Laundry Dept.	
12	Blood Bank	
13	Medical Record Dept.	
14	C.M. Store	
15	Dental College	
16	Pharmacy College	
17	Linin	
18	Garden	
19	Medical college (common pool)	
20	Bio-medical west (BMW)	
21	Bio-Medical Engineering	
22	physiotherapy College	
23	Guest House	
24	Krishna Sports Gym	
25	Casualty Dept.	
26	Photography Dept.	
27	Hospital Wards	
28		
29		
30		

Date: 20/7/18

To,
The Medical Director,
KIMSDU, Karad.

Subject: About the arrangement of Fire Hydrants training.

Respected Sir,
With the above mentioned subject Fire Hydrants training was held on 20/7/2018 at 3 pm. For the all staff of KIMSDU.
This Fire hydrants training has been arranged for to trainee all staff of KIMSDU. And aim of this training is not only trained but also they face each and every incident of fire which will be happen in the campus. Such type of training we arranging time to time as requirement of NAHR (K) & N.A.C.
Blow siren for 45 second after some time KIMSDU staff gathered at assembly point no 1 & 2. Security Supervisor has falling as dept Wise and given lecture by SO about fire hydrants and their practical (Example, Laying hose pipe, fit the nozzle, and another end of hose pipe fit in the valve, and how to hold the hose pipe with the correct position, etc. After this training actual started pump house motor, and four valve were open and given training to all present staff. Following no. of dept. people were present

Sr. No.	Department	Present No.
1	Security	25
Total		25

Yours Sincerely,
(Signature)
Shri V. V. Chavan
Security Officer
KIMSDU.

C C to
1 Asst Registrar. (Estate & Security)
2 H.R. Office ✓
3 Office Superintendent ✓
4 Quality Office K.H. ✓

Office - *(Signature)*

KIMSDU Training Record

Name of the Document: TRAINING RECORD
Name of the Participants: Security

Topic: Fire Hydrants Training
Faculty: Mr. V. V. Chavan (ASO)
Date: 20/07/2018
Venue: C.M. Store

Sr. No.	Name of Participant	Signature of Participant	Training Feedback	Effectiveness Assessment	Remarks if any
1	Mr. G. M. Patil				
2	Mr. A. S. Patil				
3	Mr. S. Patil				
4	Mr. S. Patil				
5	Mr. S. Patil				
6	Mr. S. Patil				
7	Mr. S. Patil				
8	Mr. S. Patil				
9	Mr. S. Patil				
10	Mr. S. Patil				
11	Mr. S. Patil				
12	Mr. S. Patil				
13					
14					

Remarks: ✓ Grade A: Training Conducted effectively
Grade B: Training not conducted effectively
Grade C: Training Conducted for sufficient duration
Grade D: Training Conducted for insufficient duration
Grade E: All topics covered
Grade F: Training inadequate

(Signature)

Ann XII : 05 of 06



Certificate of Registration

(Environmental Management System)

KVQA CERTIFICATION SERVICES PVT. LTD.

This is to certify that the Environmental Management System of

**KRISHNA INSTITUTE OF MEDICAL SCIENCES
"DEEMED TO BE UNIVERSITY", KARAD.**

Near Dhebewadi Road, Pune Bangalore Highway, Malkapur, Tal. Karad.
Dist. Satara – 415539, Maharashtra, India.

Has been found to be of the Environmental Management System Standard

ISO 14001:2015

This certificate is valid for the following product or service range

**Higher Education and Healthcare, State of The Art Higher Education Facilities,
Multispeciality Healthcare and Diagnostic Services Under One Roof Through its
Constituent Faculties and Teaching Hospitals.**

1st Surveillance Due On: 03/02/2021: Done On:
2nd Surveillance Due On: 03/02/2022: Done On:

Certificate No: **IESC202003001**
Date Of Issue: 03 March 2020
Valid Until: 02 March 2023*



Issued by

Authorised signatory KVQA

JAS-ANZ

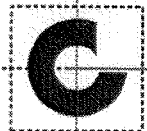

M5400913IN
www.jas-anz.org

JAS-ANZ is the government-appointed accreditation body for Australia and New Zealand responsible for providing accreditation of conformity assessment bodies (CABs) in the fields of certification and inspection. Accreditation by JAS-ANZ demonstrates the competence and independence of KVQA.

Accredited by a member of IAF's MLA for Quality Systems

To Check the Status of the Certification kindly log on to www.kvqa.in
F-300, Sector -63, Noida U.P., India. Ph-011-22711940, 22711941, email: delhi@kvqaIndia.com
*Subject to successful completion of surveillance audits

REGISTRAR

Krishna Institute of Medical Sciences
"Deemed To Be University", Karad